

ROBATIC[®], ROBA[®]-quick ROBA[®]-takt

**Electromagnetic Clutches and Brakes,
Clutch Brake Units**

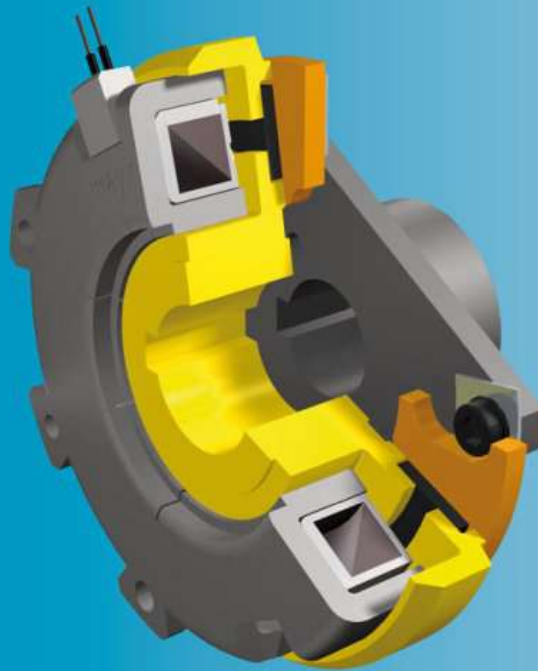

www.mayr.com

- *High torque capacity*
- *Low wear*
- *Compact construction*
- *Easy assembly and maintenance*

K.500.V09.GB

mayr[®]
your reliable partner



mayr® – your reliable partner

What is your definition of reliability?

We define reliability as the highest product quality and competent service from the initial contact right up to the after-sale service

- Largest variety in selection of standard products
- Market leader's competence arising from decades of experience in the development, production and application of power transmission products
- Optimum product selection due to our expertise in design and calculation
- Reliable component dimensioning
- Intelligent platform (modular construction)
- High flexibility for individual requests and customer-tailored solutions
- Quality-inspected suppliers
- Modern, highly robust materials
- In-house production
- 100 % quality control
- Certified according to DIN EN ISO 9001:2000
- Personal supervision from the first contact right up to the after-sale service
- Worldwide local service network
- CAD-files available online to save time and costs during construction
- 24-hour delivery service for preferred products
- Short delivery times and on-time delivery
- Unlimited replacement part availability worldwide



Your advantages when using electromagnetic ROBATIC®-clutches, ROBA®-quick brakes and ROBA®-takt clutch brake units

● Easy integration into your machine:

The optimised magnetic circuit minimises the magnetic leakage flux. The high power density and torque security based on it allow compact dimensions and an easy integration in your construction.

● High reliability and operational safety:

The switching behaviour is constant during the entire service lifetime. Therefore, the positioning accuracy and reliability of the clutches or brakes respectively and herewith the operational security of your machine are increased.

● Less operating expenses and maintenance charges:

The large friction surface and the smooth switching behaviour increase the wear resistance. Therefore, the clutches and brakes are maintenance-free until the friction surfaces are worn down. There is no re-adjustment work and the resulting operational interruptions. Therefore, the operating expenses and maintenance charges are very low.

● Increase of productivity:

Short switching times allow high switching frequencies and increase the productivity of your machine.

Total Quality Management

Product Quality

Every delivery which leaves our firm has been subjected to a careful quality inspection, meaning that you are able to rely 100 % on mayr® products. If required, we pre-adjust our clutches and brakes accurately to the requested values and confirm the product characteristics with an Inspection Report.

Quality Management

mayr® uses the term quality to describe its products and services. Certification of our quality management confirms the quality-consciousness of our colleagues at every level of the company.

Our integrated management system is certified according to **DIN EN ISO 9001:2000 (Quality)** and **DIN EN ISO 14001 (Environment)** and complies with the **OHSAS 18001/OHRIS (Occupational Health and Safety)** demands.



All products are subject to comprehensive inspections and tests regarding loads. Only after having passed the strongest long-time tests and when they fully meet all the technical requirements and proof their reliability they are included in our delivery programme.

Please Observe:

According to german notation, decimal points in this document are represented with a comma (e.g. 0,5 instead of 0.5).

Description and Operating Conditions

1. The catalogue values, in particular the values for the nominal torque, are reference values and may deviate in individual cases.
2. During dimensioning, please contact the manufacturers for consultation on installation conditions, torque fluctuations, permitted friction work, run-in behaviour, wear and ambient conditions.
3. The clutches and brakes are designed for dry running. If the friction surfaces come into contact with oil, grease or similar substances, there may be a severe decrease in torque.
4. When the devices are switched off, voltage peaks may occur due to the counter-induction on the magnetic coils, causing in extreme cases damage to the magnetic coil and therefore to the components. For this reason, excess voltage must be damped using a suitable "protective circuit" (e.g. using a varistor).
5. The surfaces on the clutches and the brakes are corrosion-protected except for the friction surfaces. However, in operation in extreme ambient conditions or in outdoor conditions with direct weather influences, additional protective measures are necessary.
6. The connection cable or connection strands on the clutches and brakes have a surface coating which is not resistant against all influences. After contact with chemical substances, please check compatibility.
7. The clutches and brakes are designed for a relative duty cycle of 100 %.

Torque Characteristics

In new condition, c. 50 % of the catalogue nominal torque (M_2) is transmitted.

The components reach the catalogue nominal torque when the friction surfaces are run in. As a rough guideline value, c. 100 – 200 switchings in dynamic operation, a typical speed (c. 50 to 1000 rpm) and a medium friction work (see Table 1) can be given.

Longer slipping of the clutch or brake is to be avoided, especially at low speeds, as this can cause scoring formation and therefore damage to the friction surfaces. Clutches or brakes used in static or virtually static operation do not reach the nominal torque (M_2).

If requested, the clutches or brakes can also be run in at the place of manufacture. This is most expedient for Type 540.140 with complete bearing.

However, Types 500.1_ _ and 520.1_ _ can also be run in under certain conditions. For this, please ensure exact installation customer-side according to the regulations in order to reproduce the friction conditions as precisely as possible. At the same time, the "friction carbon" produced must not be rubbed off. If the clutch is run in to the nominal torque at the place of manufacture and then operated in static or virtually static mode, please allow for a drop to c. 60 – 70 % of the nominal torque. This is the case if the clutch or brake falls below the speed or friction work (Q_s) stated in Table 1.

For static and virtually static applications, we therefore recommend our "double-flow designs" construction series 500.3_ _0 (see pages 12/13).

Size	Friction work Q_s [J]	Clutch or brake speed n_{min} [rpm]
3	16	300
4	29	250
5	55	200
6	105	160
7	200	130
8	380	120
9	600	100

4 Table 1

Run-in Conditions

For running in, different procedures can be used according to the Type design. An "artificial" run-in is to be carried out if a run-in procedure is not possible in the machine due to the type of application (see section "Torque Characteristics"), e.g. due to insufficient friction work, speed or switching frequencies.

For the run-in conditions of the individual clutch and brake types, please see the respective Installation and Operational Instructions on our website www.mayr.com

Electrical Connection and Wiring

DC current is necessary for the operation of the brake. The coil voltage is indicated on the Type tag as well as on the brake body and is designed according to the DIN IEC 60038 (± 10 % tolerance). Operation is possible both via alternating voltage in connection with a rectifier or with another suitable DC supply. Dependent on the brake equipment, the connection possibilities can vary. Please follow the exact connections according to the Wiring Diagram. The manufacturer and the user must observe the applicable directives and standards (e.g. DIN EN 60204-1 and DIN VDE 0580). Their observance must be guaranteed and double-checked.

Electrical Wiring

24 VDC and 104 VDC can be selected as standard voltages.

24 VDC: Operation with a power supply unit of 24 VDC

104 VDC: Half-wave rectifier with 230 VAC mains voltages

Earthing Connection

The brake is designed for Protection Class I. This protection covers not only the basic insulation but also the connection of all conductive parts to the PE conductor on the fixed installation. If the basic insulation fails, no contact voltage will remain. Please carry out a standardized inspection of the PE conductor connections to all contactable metal parts.

Device Fuses

To protect against damage from short circuits, please add suitable device fuses to the mains cable.

Protection Circuit

When using DC-side switching, the coil must be protected by a suitable protective circuit according to VDE 0580.

This is achieved by using a sufficiently dimensioned varistor, which has already been integrated into the **mayr® rectifier**.

To protect the switching contact from consumption when using DC-side switching, additional protective measures may be necessary (e.g. series connection of switching contacts). The switching contacts used should have a minimum contact opening of 3 mm and should be suitable for inductive load switching. Please make sure on selection that the rated voltage and the rated operation current are sufficient. Depending on the application, the switching contact can also be protected by other protective circuits (e.g. **mayr® spark quenching units**), although this may of course then alter the switching times.

Table of Contents

ROBATIC®

Electromagnetic, energise to engage
pole face clutches

**ROBA®-quick**

Electromagnetic, energise to engage
pole face brakes

**ROBA®-takt clutch brake module**

Clutch-brake unit



	Page
ROBATIC®	
Description	6
Summary of structural designs	7
Data sheets	
• ROBATIC®-standard Sizes 3 – 7	8 – 9
• ROBATIC®-standard Sizes 8 – 9	10 – 11
• ROBATIC® double-flow design Sizes 3 – 7	12 – 13
• ROBATIC® small mounting diameter Sizes 3 – 7	14 – 15
• ROBATIC® small mounting diameter Sizes 8 – 9	16 – 17
• ROBATIC® with bearing-supported coil carrier Sizes 3 – 9	18 – 19
• ROBATIC® with bearing-supported flange Sizes 3 – 9	20 – 21
• Technical explanations	22 – 25
• Electronic accessories	26 – 27
ROBA®-quick	
Description	28
Summary of structural designs	29
Data sheets	
• ROBA®-quick standard Sizes 3 – 7	30 – 31
• ROBA®-quick standard Sizes 8 – 9	32 – 33
• ROBA®-quick small mounting diameter Sizes 3 – 7	34 – 35
• Technical explanations	36 – 39
• Electronic accessories	40 – 41
ROBA®-takt clutch brake module	
Description	42
Summary of structural designs	43
Data sheets	
• ROBA®-takt	44 – 51
• Technical explanations	52 – 55
• Electronic accessories	56 – 58

Constant switching performance throughout the entire service lifetime

- ❑ **High torque security**
due to an optimised magnetic circuit and the new design of the ROBATIC®-clutch. Therefore, higher capacities due to less magnetic leakage flux.
- ❑ **Half the wear**
due to large friction surfaces and smooth switching behaviour, the ROBATIC®-clutch has a higher wear resistance (approx. 100 %).
- ❑ **Large internal diameters of the magnetic coil bodies**
therefore large permitted shaft diameters
- ❑ **Low noise**
- ❑ **Short switching times/high switching frequencies**
- ❑ **Correct function up to wear limit**

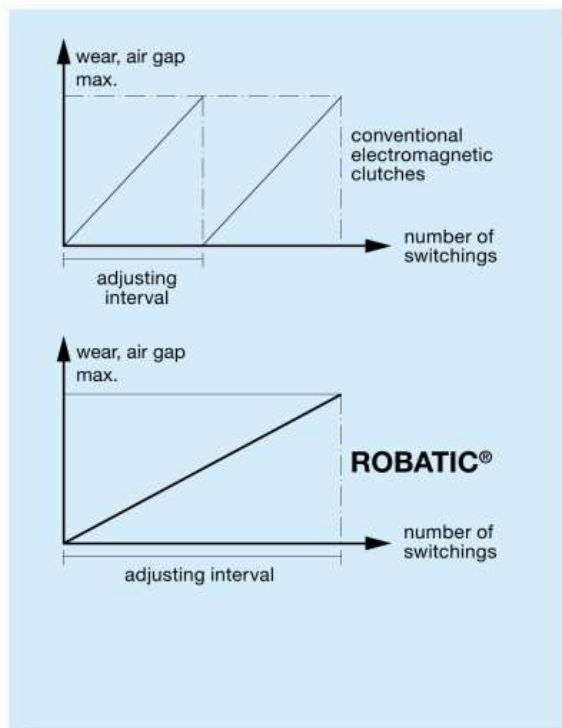
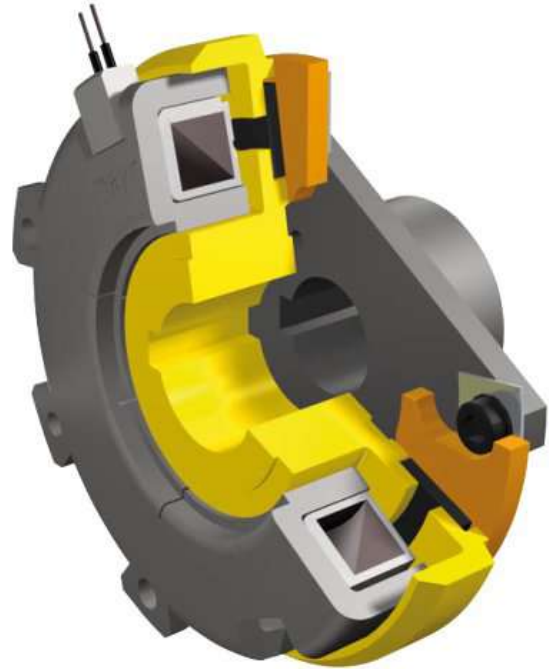

Functional principle



ROBATIC® -clutches are energised to engage, electromagnetic pole face units.

When DC voltage is applied to the magnetic coil (1), a magnetic field is built up, the armature disk (3) is attracted to the rotor (2) and the friction lining (4). The torque is transmitted via friction locking.

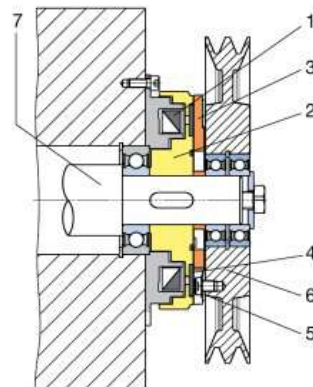
The torque is transmitted from the drive element (6) via the armature disk (3) and the rotor (2) to the output shaft (7). After having de-energised the coil, the membrane spring (5) draws back the armature disk (3) to the drive element (e.g. belt pulley), and the torque transmission is then disconnected.

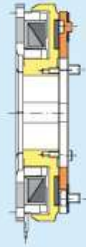
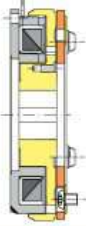
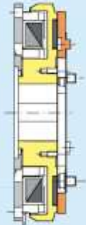

Summary of structural designs ROBATIC®

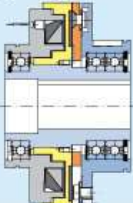
<p>ROBATIC®-standard</p> 	<p>Sizes 3 to 9 Type 500.____</p> <p>Sizes 3 to 7 Type 500.20_0</p> <p>Sizes 8 to 9 Type 500.1__</p>	<p>without accessories flange hub</p> <p>Type 500.200.0 Type 500.201.0</p> <p>without accessories flange hub</p> <p>Type 500.10_ Type 500.11_</p>	<p>Pages 8 – 11</p>
<p>ROBATIC® double-flow design</p> 	<p>Sizes 3 to 7 Type 500.30_</p>	<p>without accessories flange hub</p> <p>Type 500.300.0 Type 500.301.0</p>	<p>Pages 12 – 13</p>
<p>ROBATIC® small mounting diameter</p> 	<p>Sizes 3 to 7 Type 500.21_0</p> <p>Sizes 8 to 9 Type 580.1_0 with small bolt circle</p>	<p>without accessories flange hub</p> <p>Type 500.210.0 Type 500.211.0</p> <p>without accessories flange hub</p> <p>Type 580.100 Type 580.110</p>	<p>Pages 14 – 17</p>
<p>ROBATIC® with bearing-supported coil carrier</p> 	<p>Sizes 3 to 9 Type 540.1__</p>	<p>without accessories flange hub</p> <p>Type 540.10_ Type 540.11_</p>	<p>Pages 18 – 19</p>
<p>ROBATIC® with bearing-supported flange</p> 	<p>Sizes 3 to 9 Type 540.14_</p>	<p>Type 540.14_</p>	<p>Pages 20 – 21</p>

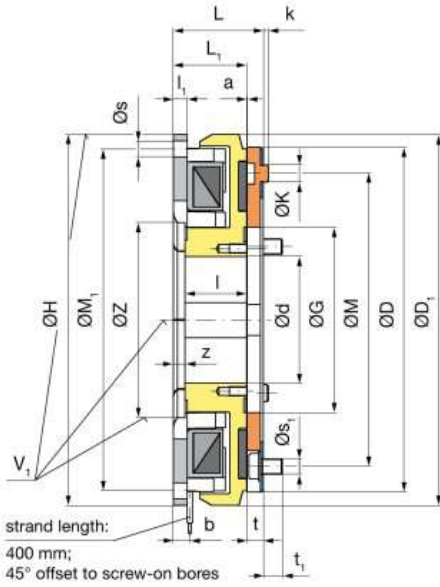

Type 500.200.0
Standard

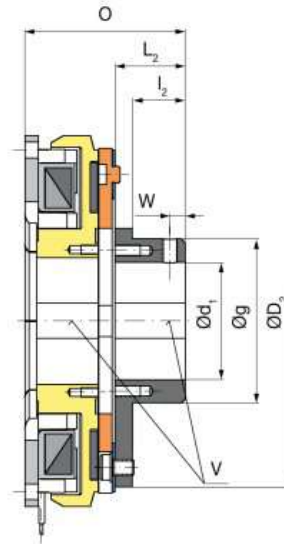

Type 500.201.0
Standard with flange hub

Order Number

_ / 5 0 0 . 2 0 _ . 0 / _ / _ / _ / _							
▲			▲	▲	▲	▲	
Sizes 3 to 7	without accessories flange hub		0 1	Coil voltage [VDC] 24 104	Rotor bore Ø d ^{H7}	Flange hub bore Ø d ₁ ^{H7}	Keyway acc. DIN 6885/1 or DIN 6885/3

Example: 6 / 500.201.0 / 24 / 35 / 40 / DIN 6885/1

ROBATIC®-electromagnetic clutch

Standard Sizes 3 – 7

Type 500.20_0

Technical Data				Size				
				3	4	5	6	7
Nominal torque ¹⁾	Type 500.20_0	M_2	[Nm]	10	20	45	80	160
Electrical power		P_{20}	[W]	18	26	37	53	79
Maximum speed		n_{max}	[rpm]	8600	7000	6100	5800	4500
Weight	without accessories	m	[kg]	0,68	1	2,15	3,48	6,6
	with flange hub	m	[kg]	0,75	1,31	2,35	4,03	7,5
Mass moment of inertia	Rotor ²⁾	I_{own}	$[10^{-4} \text{ kgm}^2]$	2	5,14	13,25	29,85	86,75
	Armature disk	I_{own}	$[10^{-4} \text{ kgm}^2]$	0,76	1,92	6,86	17,56	52,86
	Flange hub ²⁾ + Armature disk	I_{own}	$[10^{-4} \text{ kgm}^2]$	1,02	2,75	8,63	24,66	70,63

1) Please observe run-in regulations or minimum speed (see page 4).

2) With max. bore

Standard voltages 24 VDC; 104 VDC.
Permitted voltage tolerances acc. IEC 38 +/-10 %.

Bores			Size				
			3	4	5	6	7
$\varnothing d^{H7}$	Preferred bores	[mm]	10; 15	17; 20	20; 25; 30	25; 30; 35	30; 40; 50
	min.	[mm]	9	11	13	13	20
	max.	[mm]	25	35	42	55	65
$\varnothing d_1^{H7}$	Preferred bores	[mm]	17; 20	20; 25	25; 30	30; 40	40; 50
	min.	[mm]	9	13	15	20	23
	max.	[mm]	20	30	35 ³⁾	45	60

3) Up to $\varnothing 32$ keyway acc. DIN 6885/1, above $\varnothing 32$ keyway acc. DIN 6885/3

Dimensions [mm]	Size				
	3	4	5	6	7
a	0,2	0,2	0,2	0,3	0,3
b	4,5	4	5,5	5,5	7,5
D	73,5	92	115	140	177
D_1	80	100	125	150	190
D_2	70	88	110	140	170
G	36	49	57,5	74	95
g	29,5	44	47	66	84
H_{hb}	80	100	125	150	190
K	3 x 4,6	3 x 6,4	3 x 7,0	3 x 10,4	3 x 10,2
k	1,7	1,7	2,5	2,8	2,7
L	28,1	31,2	36,0	40,8	46,1
L_1	24	26,5	30	33,5	37,5
L_2	20	22	28	32	36
l	20,5	22	25	27,5	31,5

Dimensions [mm]	Size					
	3	4	5	6	7	
l_1	3,5	4,3	5,2	6	7	
l_2	16	17	22	25	27	
M	60	76	95	120	150	
M_1	72	90	112	137	175	
O	48,1	53,2	64,1	72,9	82,2	
s	4 x 4,8	4 x 5,7	4 x 6,8	4 x 6,8	4 x 9,2	
s_1	3 x M4	3 x M5	3 x M6	3 x M8	3 x M8	
t	3,9	4,5	5,8	7,0	8,3	
t_1	5,2	7,2	8,7	8,0	9,7	
Permitted shaft mis-alignm. and centre offset	V	0,05	0,05	0,05	0,05	0,1
	V_1	0,1	0,15	0,15	0,15	0,2
W	5	5	6	8	8	
Z^{H8}	42	52	62	80	100	
z	3,5	4,5	5	6	6	

We reserve the right to make dimensional and constructional alterations.

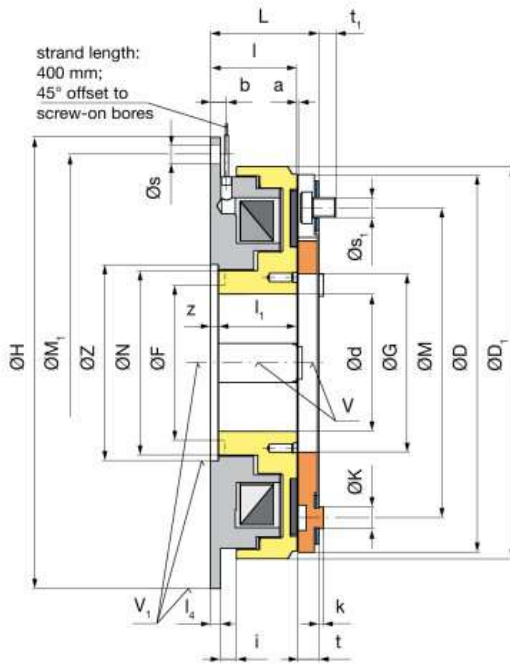

Type 500.100
Standard
with connection strand

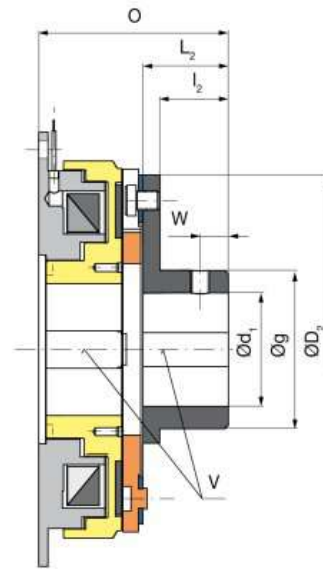

Type 500.110
Standard with flange hub
with connection strand

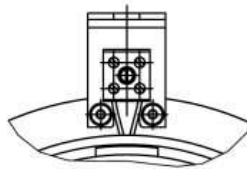

Type 500.1_2
Standard
with connecting terminal

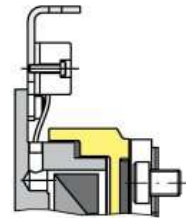

Order Number

without accessories 0
flange hub 1



__	/	5	0	0	.	1	__	/	__	/	__	/	__	/	__
▲							▲		▲		▲		▲		▲
Size							connection strand		Coil voltage		Rotor bore ³⁾		Flange hub		Keyway acc.
8							connecting terminal	0	[VDC]		Ø d ^{H7}		bore		DIN 6885/1
9								2	24				Ø d ₁ ^{H7}		or
									104						DIN 6885/3

Example: 8 / 500.100 / 24 / 40 / DIN 6885/1

ROBATIC®-electromagnetic clutch

Standard

Sizes 8 – 9

Type 500.1_ _

Technical Data				Size	
				8	9
Nominal torque ¹⁾	Type 500.1_ _	M_2	[Nm]	320	640
Electrical power		P_{20}	[W]	61	82
Maximum speed		n_{max}	[rpm]	3000	2200
Weight	without accessories	m	[kg]	10,1	20,5
	with flange hub	m	[kg]	13	25
Mass moment of inertia	Rotor ²⁾	I_{own}	[10 ⁻⁴ kgm ²]	165	450
	Armature disk	I_{own}	[10 ⁻⁴ kgm ²]	81	315
	Flange hub ²⁾ + Armature disk	I_{own}	[10 ⁻⁴ kgm ²]	107	381

1) Please observe run-in regulations or minimum speed (see page 4).

2) With max. bore

Standard voltages 24 VDC; 104 VDC.
Permitted voltage tolerances acc. IEC 38 +/-10 %.

Bores			Size	
			8	9
$\varnothing d^{H7}$	Preferred bores	[mm]	40; 50; 60	50; 60; 70
	min.	[mm]	24	34
	max.	[mm]	70	80
$\varnothing d_1^{H7}$	Preferred bores	[mm]	40; 50	50; 60
	min.	[mm]	24	27
	max.	[mm]	60	80

Dimensions [mm]	Size	
	8	9
a	0,5	0,5
b	8	9
D	193	251
D ₁	200	251
D ₂	185	242
F ³⁾	-	-
G	91	111
g	84	104
H _{hub}	230	290
i	8	9,5
K	3 x 11	4 x 20
k	2	4,2
L	55,1	63,9
L ₂	45,3	53,9
l	44	51
l ₁	40	47

3) Turning for RS-ball bearing according to order regulations – no turning is allowed for in the standard range.

Dimensions [mm]	Size		
	8	9	
l ₂	36,3	42,9	
l _s	5	6	
M	158	210	
M ₁	215	270	
N	93,9	116,8	
O	100,4	117,8	
s	4 x 9	4 x 11	
s ₁	3 x M10	4 x M12	
t	10,6	12,4	
t ₁	8,5	11,8	
Permitted shaft mis-alignm. and centre offset	V	0,1	0,1
	V ₁	0,2	0,25
W	15	20	
Z ^{HS}	100	125	
z	4	4	

We reserve the right to make dimensional and constructional alterations.

Double-flow design

Sizes 3 – 7

Type 500.30_0

strand length:
400 mm;
45° offset
to screw-on
bores

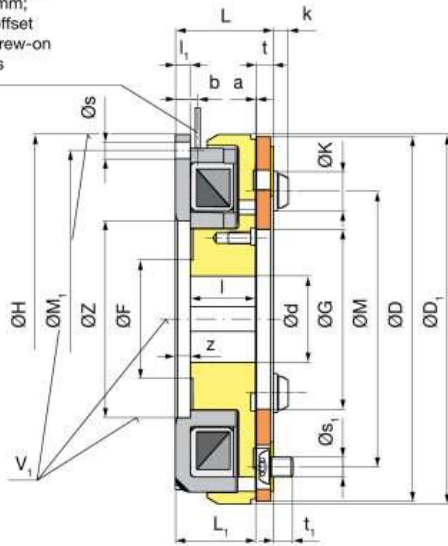

Type 500.300
Double-flow design

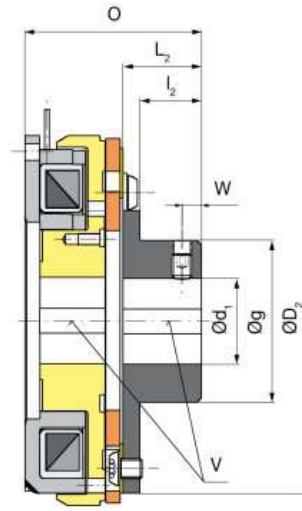

Type 500.301
Double-flow design with flange hub



Performance Characteristics

- Preferred for static or virtually static applications
- High torque security with low friction work
- No organic friction lining installed (environmentally friendly)

Order Number

<p>__ / 5 0 0 . 3 0 __ . 0 / __ / __ / __ / __</p>						
▲		▲	▲	▲	▲	▲
Sizes 3 to 7	without accessories flange hub	0 1	Coil voltage [VDC] 24 104	Rotor bore Ø d ^{H7}	Flange hub bore Ø d ₁ ^{H7}	Keyway acc. DIN 6885/1

Example: 6 / 500.301 / 24 / 35 / 40 / DIN 6885/1

ROBATIC®-electromagnetic clutch

Double-flow design Sizes 3 – 7
Type 500.30_0

Technical Data				Size				
				3	4	5	6	7
Nominal torque ¹⁾²⁾ (+50% /-12%) Type 500.30_0	M_2	[Nm]	20	40	90	160	320	
Electrical power	P_{20}	[W]	17	25	37	50	79	
Maximum speed ³⁾	n_{max}	[rpm]	8600	7000	6100	5800	4500	
Weight	without accessories	m	0,65	1,16	2,02	3,3	6,22	
	with flange hub	m	0,76	1,5	2,53	4,46	8,09	
Mass moment of inertia	Rotor ⁴⁾	I_{own}	[10 ⁻⁴ kgm ²]	2,02	5,56	14,08	32,26	106,36
	Armature disk	I_{own}	[10 ⁻⁴ kgm ²]	1,08	2,69	7,34	19,92	61,57
	Flange hub ⁴⁾ + Armature disk	I_{own}	[10 ⁻⁴ kgm ²]	1,46	3,98	10,26	30,43	89,01

1) Please observe run-in regulations or minimum speed (see page 4).

2) During permanent synchronisation without friction work, the torque may drop to 50 % - 60 % of the nominal torque.

3) Max. switching speed is dependent on friction work and switching frequency - **if necessary, please contact the manufacturer.**

4) With max. bore

Standard voltages 24 VDC; 104 VDC.
Permitted voltage tolerances acc. IEC 38 +/-10 %.

Bores			Size				
			3	4	5	6	7
$\varnothing d$ ^{H7}	Preferred bores	[mm]	15, 20	20, 25, 28	30, 35, 40	45, 50	55, 60
	min. ⁵⁾	[mm]	14	19	30	42	55
	max.	[mm]	25	35	42	55	65
$\varnothing d_1$ ^{H7}	Preferred bores	[mm]	15, 17, 20	20, 25, 28	25, 30	35, 40, 45	50, 55, 60
	min. ⁵⁾	[mm]	14	19	24	32	50
	max.	[mm]	20	30	32	45	60

5) For torques smaller than the nominal torque M_2 , bores below d_{min} are possible on request.

Dimensions [mm]	Size				
	3	4	5	6	7
a	0,2	0,2	0,2	0,3	0,3
b	4,5	4	5,5	5,5	7,5
D	79	99	123,5	148	188
D₁	80	100	125	150	190
D₂	70	88	110	140	170
F ⁶⁾	-	-	-	-	-
G	32	49	55	73	95
g	29,5	44	47	66	84
H₁₀	80	100	125	150	190
K	3x8	3x10	3x12	3x16	3x14
k	3,2	3,8	4,3	6	4,4
L	28,1	31,25	35,7	40,7	46,1
L₁	23,5	26,5	30	33,5	37,5
L₂	20	22	28	32	36
l	20	22	25	27,5	31,5

6) Turning for RS-ball bearing according to order regulations – no turning is allowed for in the standard range.

Dimensions [mm]	Size					
	3	4	5	6	7	
l₁	3,5	4,3	5,2	6	7	
l₂	16	17	22	25	27	
M	60	76	95	120	150	
M₁	72	90	112	137	175	
O	48,1	53,25	63,7	72,7	82,2	
s	4x4,8	4x5,7	4x6,8	4x6,8	4x9,2	
s₁	3xM4	3xM5	3xM6	3xM8	3xM8	
t	4,3	4,45	5,5	6,9	8,3	
t₁	5	7,2	8,7	14	13,7	
Permitted shaft mis-alignm. and centre offset	V	0,05	0,05	0,05	0,05	0,1
	V₁	0,1	0,15	0,15	0,15	0,2
W	5	5	6	8	8	
Z^{H8}	42	52	62	80	100	
z	3,5	4,5	5	6	6	

We reserve the right to make dimensional and constructional alterations.

For detailed information, please see our brochure P.500.V_..._GB

Small mounting diameter

Sizes 3 – 7

Type 500.21_0

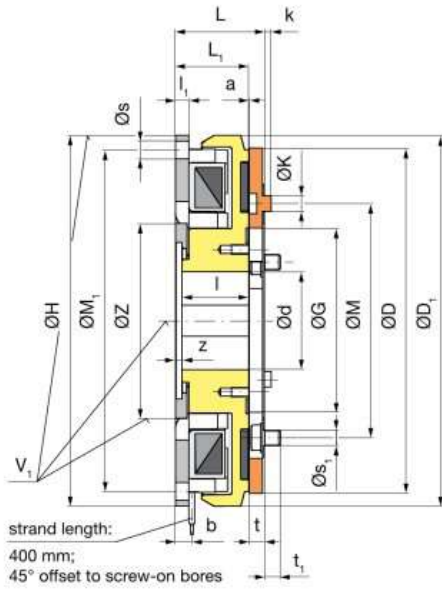

Type 500.210.0
Small mounting diameter

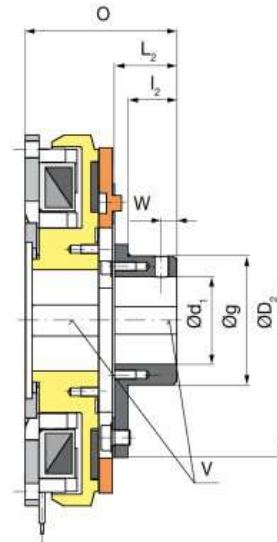

Type 500.211.0
Small mounting diameter
with flange hub

Order Number

<p>__ / 5 0 0 . 2 1 __ . 0 / __ / __ / __ / __</p>								
▲				▲	▲	▲	▲	
Sizes 3 to 7	without accessories flange hub			0 1	Coil voltage [VDC] 24 104	Rotor bore Ø d ^{H7}	Flange hub bore Ø d ₁ ^{H7}	Keyway acc. DIN 6885/1 or DIN 6885/3

Example: 6 / 500.211.0 / 24 / 40 / 30 / DIN 6885/1

ROBATIC®-electromagnetic clutch

Small mounting diameter

Sizes 3 – 7

Type 500.21_0

Technical Data				Size				
				3	4	5	6	7
Nominal torque ¹⁾	Type 500.21_0	M_2	[Nm]	10	20	45	80	160
Electrical power		P_{20}	[W]	18	26	37	53	79
Maximum speed		n_{max}	[rpm]	8600	7000	6100	5800	4500
Weight	without accessories	m	[kg]	0,65	1,1	2,1	3,4	6,4
	with flange hub	m	[kg]	0,7	1,16	2,25	3,6	6,95
Mass moment of inertia	Rotor ²⁾	I_{own}	$[10^{-4} \text{ kgm}^2]$	2,2	5,3	13,47	32,31	90,13
	Armature disk	I_{own}	$[10^{-4} \text{ kgm}^2]$	0,7	1,79	6,28	15,77	48,1
	Flange hub ²⁾ + Armature disk	I_{own}	$[10^{-4} \text{ kgm}^2]$	0,8	1,97	7,19	17,45	55,2

1) Please observe run-in regulations or minimum speed (see page 4).

2) With max. bore

Standard voltages 24 VDC; 104 VDC.
Permitted voltage tolerances acc. IEC 38 +/-10 %.

Bores			Size				
			3	4	5	6	7
$\varnothing d^{H7}$	Preferred bores	[mm]	10; 15	17; 20	20; 25; 30	25; 30; 35	30; 40; 50
	min.	[mm]	9	11	13	13	20
	max.	[mm]	20	28	35	42	55
$\varnothing d_1^{H7}$	Preferred bores	[mm]	10; 15	17; 20	20; 25	25; 30	30; 40
	min.	[mm]	8	9	13	15	20
	max.	[mm]	17	20	30	35 ³⁾	45

3) Up to $\varnothing 32$ keyway acc. DIN 6885/1, above $\varnothing 32$ keyway acc. DIN 6885/3

Dimensions [mm]	Size				
	3	4	5	6	7
a	0,2	0,2	0,2	0,3	0,3
b	4,5	4	5,5	5,5	7,5
D	73,5	92	115	140	177
D_1	80	100	125	150	190
D_2	54	70	88	110	140
G	36	49	57,5	74	95
g	27	29,5	44	47	66
H_{hub}	80	100	125	150	190
K	3 x 4,3	3 x 4,6	3 x 6,4	3 x 7	3 x 10,4
k	1,5	1,7	1,5	2,2	2,7
L	28,1	31,1	36,0	40,4	45,8
L_1	24	26,5	30	33,5	37,5
L_2	15	20	22	28	32
l	22	24	27	30	34

Dimensions [mm]	Size					
	3	4	5	6	7	
l_1	3,5	4,3	5,2	6	7	
l_2	11,5	16	17	22	25	
M	46	60	76	95	120	
M_1	72	90	112	137	175	
O	43,1	51,1	58,1	68,8	77,9	
s	4 x 4,5	4 x 5,7	4 x 6,8	4 x 6,8	4 x 9,2	
s_1	3 x M3	3 x M4	3 x M5	3 x M6	3 x M8	
t	3,9	4,4	5,8	6,6	8,0	
t_1	4,1	5,2	6,7	8,7	8,0	
Permitted shaft mis-alignm. and centre offset	V	0,05	0,05	0,05	0,05	0,1
	V_1	0,1	0,15	0,15	0,15	0,2
W	5	5	6	8	8	
Z^{H8}	35	42	52	62	80	
z	2	2,5	3	3,5	3,5	

We reserve the right to make dimensional and constructional alterations.

Small mounting diameter

Sizes 8 – 9

Type 580.1_0

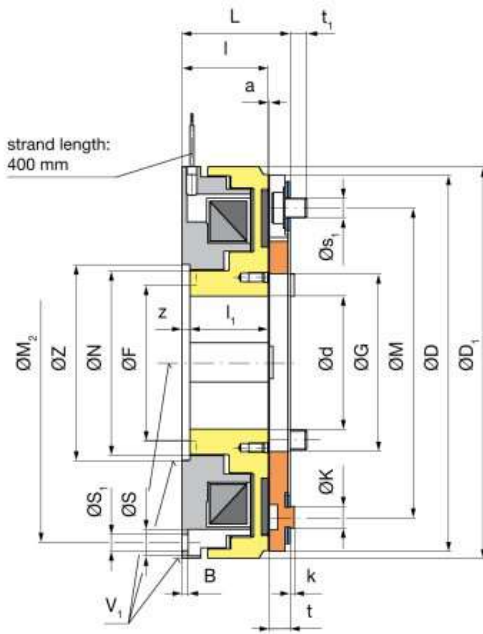

Type 580.100
Coil carrier with small bolt circle

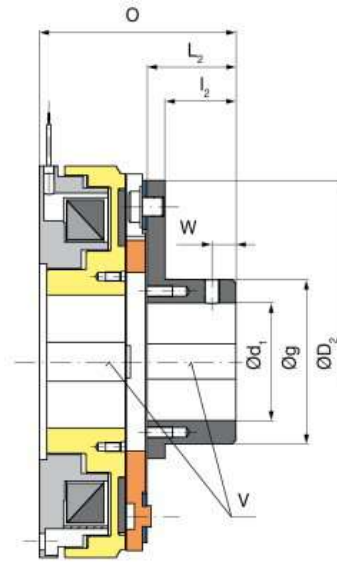

Type 580.110
Coil carrier with small bolt circle and flange hub

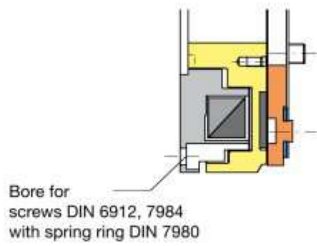

Order Number

__	/	5	8	0	.	1	__	0	/	__	/	__	/	__	/	__
▲							▲		▲	▲	▲					
Size								Coil voltage [VDC]		Rotor bore	Flange hub bore					Keyway acc.
8								24		Ø d ^{H7}	Ø d ₁ ^{H7}					DIN 6885/1
9								104								or DIN 6885/3

Example: 8 / 580.110 / 24 / 40 / 40 / DIN 6885/1

ROBATIC®-electromagnetic clutch

Small mounting diameter

Sizes 8 – 9

Type 580.1_0

Technical Data				Size	
				8	9
Nominal torque ¹⁾	Type 580.1_0	M_2	[Nm]	320	640
Electrical power		P_{20}	[W]	74	77
Maximum speed		n_{max}	[rpm]	3000	2200
Weight	without accessories	m	[kg]	10,1	20,5
	with flange hub	m	[kg]	13	23,5
Mass moment of inertia	Rotor ²⁾	I_{own}	$[10^{-4} \text{ kgm}^2]$	165	450
	Armature disk	I_{own}	$[10^{-4} \text{ kgm}^2]$	81	315
	Flange hub ²⁾ + Armature disk	I_{own}	$[10^{-4} \text{ kgm}^2]$	107	381

1) Please observe run-in regulations or minimum speed (see page 4).

2) With max. bore

Standard voltages 24 VDC; 104 VDC.
Permitted voltage tolerances acc. IEC 38 +/-10 %.

Bores			Size	
			8	9
$\varnothing d$ ^{H7}	Preferred bores	[mm]	40; 50; 60	50; 60; 70
	min.	[mm]	24	34
	max.	[mm]	70	80
$\varnothing d_1$ ^{H7}	Preferred bores	[mm]	40; 50	50; 60
	min.	[mm]	24	27
	max.	[mm]	60	80

Dimensions [mm]	Size	
	8	9
a	0,5	0,5
B	3	3
D	193	251
D ₁	200	251
D ₂	185	242
F ³⁾	-	-
G	91	111
g	84	104
H _{hg}	230	290
i	8	9,5
K	3 x 11	4 x 20
k	2	4,2
L	55,1	63,9
L ₂	45,3	53,9
l	44	51
l ₁	40	47

3) Turning for RS-ball bearing according to order regulations – no turning is allowed for in the standard range.

Dimensions [mm]	Size		
	8	9	
t	10,6	12,4	
l ₂	36,3	42,9	
M	158	210	
M ₂	184	235	
N	93,9	116,8	
O	100,4	117,8	
S	13,5	13,5	
S ₁	3 x 8,4	3 x 8,4	
s ₁	3 x M10	4 x M12	
t ₁	8,5	11,8	
Permitted shaft mis-alignm. and centre offset	V	0,1	0,1
	V ₁	0,2	0,25
W	15	20	
Z ^{HS}	100	125	
z	4	4	

We reserve the right to make dimensional and constructional alterations.

With bearing-supported coil carrier

Sizes 3 – 9

Type 540.1_ _

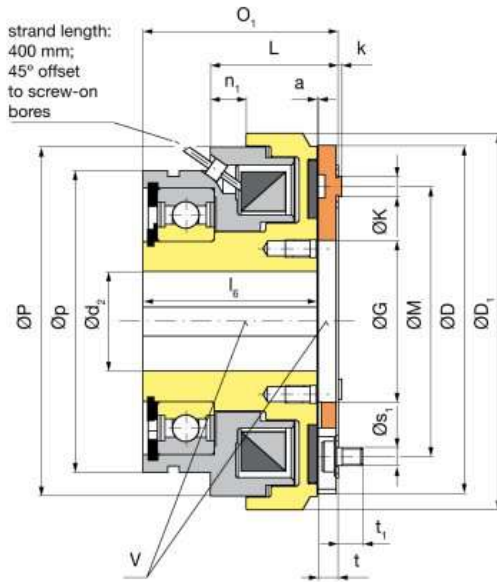

Type 540.100
With bearing-supported coil carrier

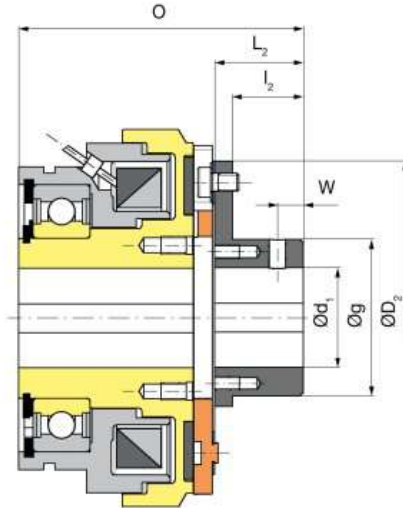

Type 540.110
With bearing-supported coil carrier and flange hub

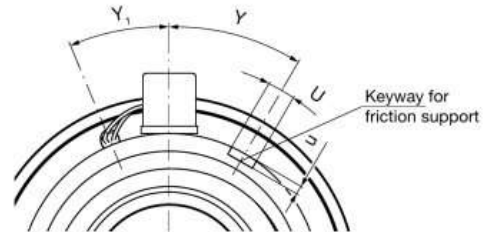
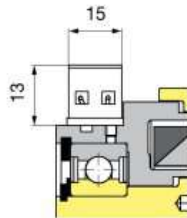

Type 540.1_2
With connecting terminal

Order Number

without accessories 0
flange hub 1

_ / 5 4 0 . 1 _ _ / _ / _ / _ / _							
▲			▲	▲	▲	▲	
Sizes 3 to 9		connecting strand connecting terminal	0 2	Coil voltage [VDC] 24 104	Rotor bore Ø d ₂	Keyway acc. DIN 6885/1 or DIN 6885/3	Flange hub bore Ø d ₁

ROBATIC®-electromagnetic clutch

With bearing-supported coil carrier

Sizes 3 – 9

Type 540.1_ _

Technical Data				Size						
				3	4	5	6	7	8	9
Nominal torque ¹⁾	Type 540.1_ _	M_2	[Nm]	10	20	45	80	160	320	640
Electrical power		P_{20}	[W]	18	19	28	38	46	61	82
Maximum speed		n_{max}	[rpm]	8000	6000	5000	4200	3600	3000	2200
Weight	without accessories	m	[kg]	0,73	1,22	1,85	3,16	5,54	11,6	22,2
	with flange hub	m	[kg]	0,78	1,29	2,01	3,38	6,11	12,86	23,93
Mass moment of inertia	Rotor ²⁾	I_{own}	$[10^{-4} \text{ kgm}^2]$	1,37	3,35	9,36	20,8	54,4	178	462
	Armature disk	I_{own}	$[10^{-4} \text{ kgm}^2]$	0,35	1,05	2,97	7,04	14	81	315
	Flange hub ²⁾ + Armature disk	I_{own}	$[10^{-4} \text{ kgm}^2]$	0,5	1,5	4,5	10,9	37,1	107	381

1) Please observe run-in regulations or minimum speed (see page 4).

2) With max. bore

Standard voltages 24 VDC; 104 VDC.
Permitted voltage tolerances acc. IEC 38 +/-10 %.

Bores				Size						
				3	4	5	6	7	8	9
$\varnothing d_2^{H7}$	Preferred bores	[mm]	10; 15	17; 20	20; 25; 30	20; 25; 30	25; 30; 40	40; 45; 50	40; 50; 60	
	min.	[mm]	7	8	12	12	19	22	30	
	max.	[mm]	20 ³⁾	25 ³⁾	30	40	50	60	65	
$\varnothing d_1^{H7}$	Preferred bores	[mm]	10; 15	17; 20	20; 25	25; 30	30; 40	40; 50	50; 60	
	min.	[mm]	8	9	13	15	20	24	27	
	max.	[mm]	17	20	30	35 ⁴⁾	45	60	80	

3) With max. bore keyway to DIN 6885/3

4) Up to $\varnothing 32$ keyway acc. DIN 6885/1, above $\varnothing 32$ keyway acc. DIN 6885/3

Dimensions [mm]	Size							
	3	4	5	6	7	8	9	
a	0,2	0,2	0,2	0,3	0,3	0,5	0,5	
D	64,5	81,5	99	118	151	193	251	
D ₁	70	87	106	125	157	200	251	
D ₂	55	70	88	110	140	185	242	
G	29,5	30,5	45,5	48	69	91	111	
g	27	29,5	44	47	66	84	104	
K	3 x 4,3	3 x 4,6	3 x 5,8	3 x 7	3 x 9,4	3 x 11,5	4 x 20	
k	0,8	1,7	1,0	1,0	2,0	2,0	4,2	
L	28	31	35,9	40,5	46,5	55,4	63,9	
L ₂	15	20	25	29,5	38	45,3	53,9	
l ₂	11,5	16	20	23,5	31	36,3	42,9	
l _b	40	43,5	49	55	61,5	74	81	
M	46	60	76	95	120	158	210	
n ₁	9	9	10	10,5	12	13	15,5	

Dimensions [mm]	Size							
	3	4	5	6	7	8	9	
O	59	68	79,9	91,5	108,5	130,4	147,8	
O ₁	44	48	54,9	62,0	70,5	85,1	93,9	
P	70	79,7	98,2	115,4	150,4	189,4	235,8	
p	64	72	85	105	120	145	150	
s ₁	3 x M3 3 x M4 3 x M5 3 x M6 3 x M8 3 x M10 3 x M12							
t	3,8	4,3	5,7	6,7	8,7	10,6	12,4	
t ₁	4,1	5,0	6,9	6,7	8,2	8,5	11,8	
U	6	8	8	10	12	14	14	
u	2	2,5	2,5	2,5	3	4,5	6	
Permitted shaft misalignment	V	0,05	0,05	0,05	0,05	0,1	0,1	0,1
	W	5	5	6	10	10	15	20
Y	[°]	45	45	30	30	30	30	
Y ₁	[°]	30	30	22,5	22,5	15	15	15

We reserve the right to make dimensional and constructional alterations.

With bearing-supported flange ¹⁾ Sizes 3 – 9

Type 540.14_

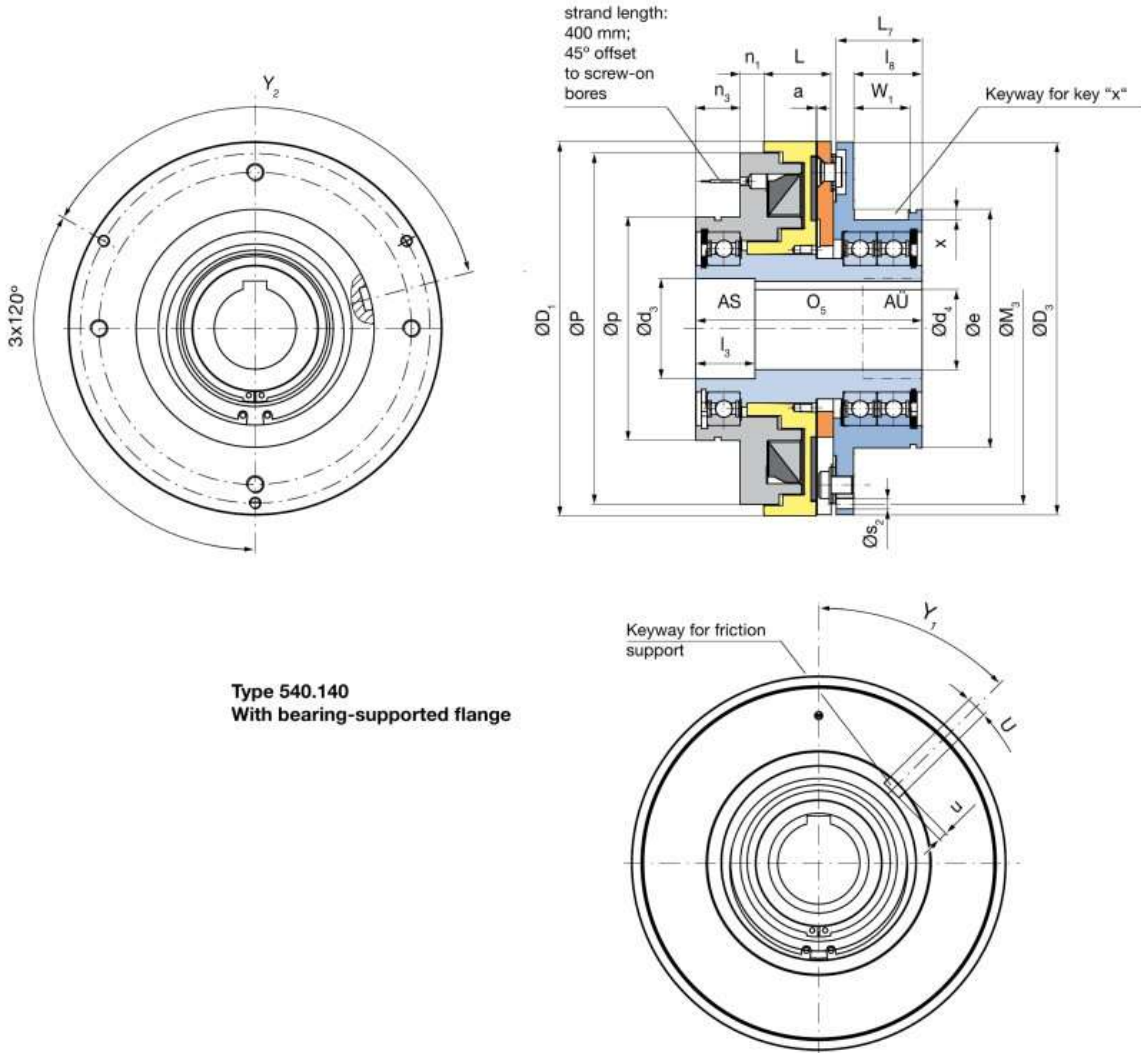

Type 540.140
With bearing-supported flange

Order Number						
_ / 5 4 0 . 1 4 _ / _ / _ / _ / _						
▲			▲	▲	▲	▲
Sizes 3 to 9	connecting strand connecting terminal	0 2	Coil voltage [VDC] 24 104	Hub bore Ø d ₁	Keyway acc. DIN 6885/1 or DIN 6885/3	Counterbore: coil carrier side AS transmission flange side AÜ

Example: 5 / 540.140 / 24 / 24 / 6885/1 / AS

ROBATIC®-electromagnetic clutch

With bearing-supported flange¹⁾ Sizes 3 – 9

Type 540.14_

Technical Data				Size						
				3	4	5	6	7 ^{γ)}	8 ^{γ)}	9 ^{γ)}
Nominal torque ²⁾	Type 540.14_	M_2	[Nm]	10	20	45	80	160	320	640
Electrical power		P_{20}	[W]	18	19	28	38	46	61	82
Maximum speed		n_{max}	[rpm]	8000	6000	5000	4200	3600	3000	2200
Weight	with max. bore	m	[kg]	1,2	1,85	2,95	4,7	8,25	16,6	29,2
Mass moment of inertia	Rotor (max. bore)	I_{own}	[10 ⁻⁴ kgm ²]	1,59	3,82	10,24	23,22	52,05	197,66	497
	Armature disk + driver flange	I_{own}	[10 ⁻⁴ kgm ²]	1,97	4,06	9,95	22,93	50,53	147,83	533,7

1) 2-shaft connection on request

2) Please observe run-in regulations or minimum speed (see page 4).

γ) From Size 7 on, the installation of a key in the driver flange is necessary in order to ensure torque transmission.

Standard voltages 24 VDC; 104 VDC.
Permitted voltage tolerances acc. IEC 38 +/-10 %.

Bores			Size						
			3	4	5	6	7	8	9
$\varnothing d_4$	maximum	[mm]	15	19 ³⁾	24	33	46	58	65
$\varnothing d_3$		[mm]	16	20	26	26 ⁴⁾ 37 ⁵⁾	37 ⁶⁾ 47 ⁷⁾ / _ ⁸⁾	37 ⁶⁾ 47 ⁷⁾ 59 ⁸⁾	47 ⁹⁾ 67 ⁹⁾ _ ¹⁰⁾

3) Above $\varnothing 18$ keyway to DIN 6885/3 with $d_{j,max}$ – depth of hub keyway 1,2¹⁰⁾

4) above $\varnothing d_4$ to 19

5) above $\varnothing d_4$ over 19

6) above $\varnothing d_4$ to 28

7) above $\varnothing d_4$ over 28

8) above $\varnothing d_4$ over 38

9) above $\varnothing d_4$ to 38

10) above $\varnothing d_4$ over 55

Dimensions [mm]	Size						
	3	4	5	6	7	8	9
a	0,2	0,2	0,2	0,3	0,3	0,5	0,5
D_1	70	87	106	125	157	200	251
D_3	71	82	102	122	156	199	250
G	29,5	30,5	45,5	48	69	91	111
e_{H6}	56	64	75	90	110	135	160
L	28	31	35,9	40,5	46,5	55,4	63,9
L_7	25,8	29,7	38,7	43,5	48,9	53,9	57,1
l_3	35	45 ¹¹⁾ 35 ¹²⁾	50 ⁴⁾ 40 ⁵⁾	60 ⁴⁾ 40 ⁵⁾	55 ⁶⁾ 35 ⁷⁾	75 ⁶⁾ 55 ⁷⁾	70 ⁹⁾ 40 ⁸⁾
l_6	21,5	24	30	34	39	44	46
M_3	66	75	94	112	145	184	235
n_1	9	9	10	10,5	12	13	15,5
n_3	16	17	19	21,5	24	30	30

11) above $\varnothing d_4$ to 14

12) above $\varnothing d_4$ over 14

13) From Size 7 on, the installation of a key in the driver flange is necessary in order to ensure torque transmission.

Dimensions [mm]	Size						
	3	4	5	6	7	8	9
O_5	70	78	94	106	120	140	152
P	70	79,7	98,2	115,4	150,4	189,4	235,8
p	64	72	85	105	120	145	150
s_2	3 x M4	3 x M5	3 x M5	3 x M6	3 x M8	3 x M8	3 x M8
U	6	8	8	10	12	14	14
u	2	2,5	2,5	2,5	3	4,5	6
W_1	17,5	19	24,5	28	31	36	38
Key X ¹³⁾	6x6 x16	6x6 x18	8x7 x22	10x8 x25	10x8 x28	14x9 x32	16x10 x36
x	3,5	3,5	4	5	5	5,5	6
Y_1 [°]	75	75	52,5	52,5	45	45	45
Y_2 [°]	90	90	90	90	90	90	135

We reserve the right to make dimensional and constructional alterations.

Installation Guidelines

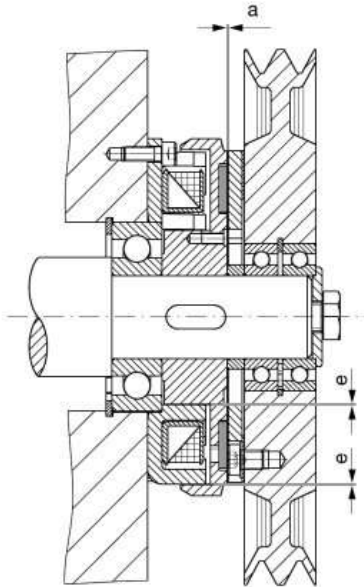

Fig. 1

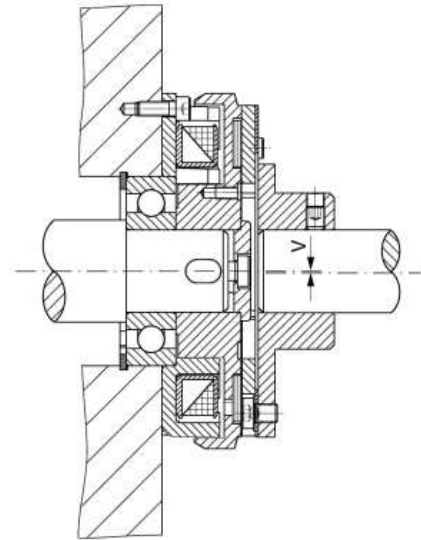

Fig. 2

	Size						
	3	4	5	6	7	8	9
a	0,2 ^{+0,1} _{-0,05}	0,2 ^{+0,15} _{-0,05}	0,2 ^{+0,15} _{-0,05}	0,3 ^{+0,15} _{-0,05}	0,3 ^{+0,15} _{-0,05}	0,5 ^{+0,15} _{-0,1}	0,5 ^{+0,15} _{-0,1}
e	0,25	0,3	0,2	0,35	0,5	0,55	0,6

Table 1 Adjustment of the air gaps

	Size						
	3	4	5	6	7	8	9
V	0,05	0,05	0,05	0,05	0,1	0,1	0,1

Table 2 Permitted shaft misalignments

The dimension "a" (Fig. 1) must be adjusted according to Table 1. Please ensure that the shaft is fastened axially, since otherwise the dimension "a" will change and cause the rotor to brush against the armature disk or the coil carrier.
 The air gap "e" is selected so that a brushing of the rotor against the coil carrier is not possible when keeping to the permitted centre offsets V and V1 (see Table "Dimensions").

Design:

ROBATIC®-electromagnetic clutches are manufactured according to the electric protection IP 54 specification and the insulation material class F up to 155 °C for coil, moulding compound and connection strands as well as insulation class B +130 °C for the magnetic coil plastic-coated. The friction linings are asbestos-free, the surfaces of coil carrier, rotor and flange hub are phosphated. The armature disk is gas nitro-carburized and the transmission spring is made of stainless steel. The drive elements should be made of magnetically poorly transmitting material to avoid magnetic leakage flux and subsequent power reduction.

ROBATIC®-electromagnetic clutches are used for dry running. The torque is transmitted via the connection of the armature disk on the iron poles and the friction lining of the rotor (except the double-flow ROBATIC® clutch without friction lining, Type 500.30_0).

When coupling two shafts, the eccentricity "V" of the shafts according to Table 2 must not be exceeded. The larger the misalignment "V" the more the torque decreases and the hotter the friction surface becomes. In the case of this arrangement care must be taken that both shafts have no axial backlash since, otherwise, a brushing of the rotor would also be possible. The flange hub is kept axially by means of a set screw (on set 90 ° to the key). The "V"-values are indicated again in the Technical Data of the individual clutches.

Please observe:

The run-in conditions or the minimum speed must be observed (see page 4).

The friction surfaces have to be absolutely free of oil and grease, as otherwise, the torque drops significantly. The air gap "a" (Fig. 1) has to be checked periodically. The clutch does not function correctly, if the max. working air gap is exceeded (see Table 4, page 25).

Assembly and maintenance should be carried out by well trained specialists.

Clutch size calculation

Formulas

1. Drive torque

$$M_A = \frac{9550 \times P_A}{n} \quad [\text{Nm}]$$

2. Required torque

$$M_{\text{req.}} \geq K \times M_A \quad [\text{Nm}]$$

3. Switchable torque of the clutch (acc. to diagram 1, page 24)

$$M_S \geq M_{\text{req.}} \quad [\text{Nm}]$$

4. Mass moment of inertia

$$I = I_{\text{own}} + I_{\text{add.}} \quad [\text{kgm}^2]$$

5. Acceleration torque of the clutch

$$M_a = M_S (+) M_L \quad [\text{Nm}]$$

6. Acceleration time

$$t_a = \frac{I \times n}{9,55 \times M_a} + t_1 \quad [\text{sec}]$$

7. Max. switching frequency per hour (dependent on time)

$$S_{h \text{ max}} = \frac{1}{t_{\text{VM}} + (t_a + t_2) \times 1,2} \times 3600 \quad [\text{h}^{-1}]$$

8. Friction work per acceleration

$$Q_a = \frac{I \times n^2}{182,4} \times \frac{M_s}{M_a} \quad [\text{J}]$$

9. Examination of the selected clutch size in diagram 2 (page 24 friction power diagram).

Intersection friction work / switching frequency must be below the friction power curve! If it is above, the next size has to be selected and re-calculated from point 3 on.

$$Q_a < Q_E \quad [\text{J}]$$

10. Number of switchings until re-adjustment

$$Z_n = \frac{Q_1}{Q_a} \times (a_n - a) \quad [-]$$

11. Number of switchings until wear limit

$$Z = \frac{Q_{\text{tot.}}}{Q_a} \quad [-]$$

Key:

P_A	[kW]	drive power	
M_A	[Nm]	drive torque	
M_a	[Nm]	acceleration torque of the clutch	
$M_{\text{req.}}$	[Nm]	required torque	
M_L	[Nm]	load torque (+ = drop load) (- = lift load)	
M_S	[Nm]	switchable torque of the clutch (diagram 1, page 24)	
n	[rpm]	drive speed	
K		safety factor	≥ 2
I	[kgm ²]	mass moment of inertia	
I_{own}	[kgm ²]	own mass moment of inertia ("Technical data")	
$I_{\text{add.}}$	[kgm ²]	additional mass moment of inertia	
t_a	[sec]	acceleration time	
t_{VM}	[sec]	braking time of the machine	
t_1	[sec]	switch-on time of the clutch	Table 3, page 25
t_2	[sec]	switch-off time of the clutch	
$S_{h \text{ max}}$	[h ⁻¹]	max. switching frequency per hour (dependent on time)	
$Q_{\text{tot.}}$	[J]	total friction work (acc. Table 4, page 25)	
Q_a	[J]	total friction work per acceleration	
Q_E	[J]	perm. friction work for single switching	Table 4, page 25
Q_1	[J/mm]	friction work until 1 mm wear	
Z_n		number of switchings until re-adjustment	
Z		number of switchings until wear limit	
a	[mm]	nominal air gap	Table 4, page 25
a_n	[mm]	max. working air gap	

Calculation example

Data:

Input power	P_A	= 3 kW
Input speed	n	= 1400 rpm
Load torque output	M_L	= 15 Nm
Additional mass moment of inertia	$I_{add.}$	= 0,15 kgm ²
Braking time of the machine	t_{vM}	= 1,5 [sec]
180 switchings per hour		

Drive torque

$$M_A = \frac{9550 \times P_A}{n} = \frac{9550 \times 3}{1400} = 20,5 \text{ [Nm]}$$

Required torque

$$M_{req.} = K \times M_A = 2 \times 20,5 = 41 \text{ [Nm]}$$

Determined clutch size (acc. to diagram 1) = Size 6

$$M_S \geq M_{req.} = 47 \text{ [Nm]}$$

Selected clutch = Size 6, type 500.200.0

Mass moment of inertia

$$I = I_{own} + I_{add.} = 0,001756 + 0,15 = 0,151756 \text{ [kgm}^2\text{]}$$

Acceleration torque of the clutch

$$M_a = M_S - M_L = 47 - 15 = 32 \text{ [Nm]}$$

Acceleration time of the clutch

$$t_a = \frac{I \times n}{9,55 \times M_a} + t_1^* = \frac{0,151756 \times 1400}{9,55 \times 32} + 0,15 = 0,845 \text{ [sec]}$$

* Switching times t_1 and t_2 from Table 3, page 25 = without overexcitation

Max. switching frequency per hour

$$S_{n \max} = \frac{1}{t_{vM} + (t_a + t_2^*) \times 1,2} \times 3600$$

$$S_{n \max} = \frac{1}{1,5 + (0,845 + 0,060) \times 1,2} \times 3600 = 1392 \text{ [h}^{-1}\text{]}$$

Friction work per acceleration

$$Q_a = \frac{I \times n^2}{182,4} \times \frac{M_S}{M_a}$$

$$Q_a = \frac{0,151756 \times 1400^2}{182,4} \times \frac{47}{32} = 2395 \text{ [J]} \leq Q_E$$

The point of intersection determined in diagram 2 must be located in or under the characteristic curve of the selected clutch.
Switching frequency: 180 switchings per hour = permitted

Number of switchings until adjustment

$$Z_n = \frac{Q_1}{Q_a} \times (a_n - a)$$

$$Z_n = \frac{57 \times 10^7}{2395} \times (1,2 - 0,3) = 214196 \text{ switchings}$$

Number of switchings until wear limit

$$Z = \frac{Q_{tot.}}{Q_a} = \frac{100 \times 10^7}{2395} = 417536 \text{ switchings}$$

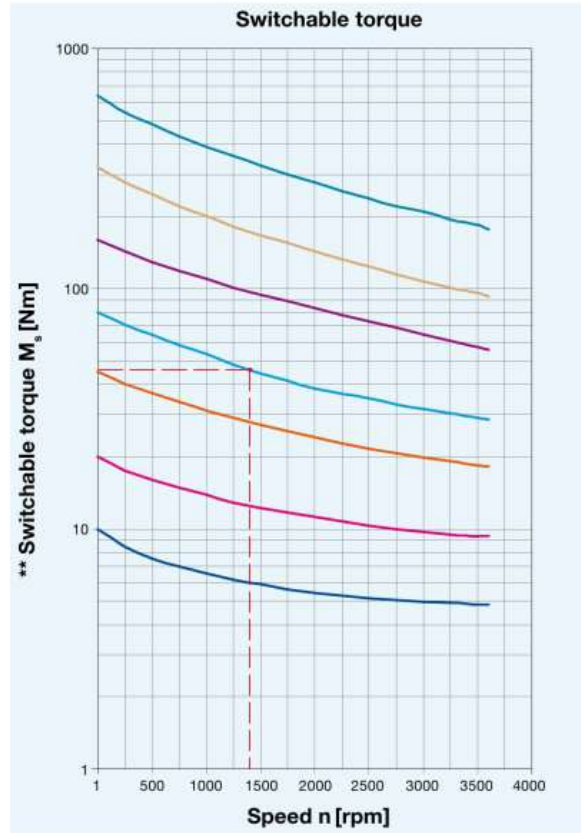

Diagram 1 (not valid for Type 500.30_) ** Friction surfaces have been run in

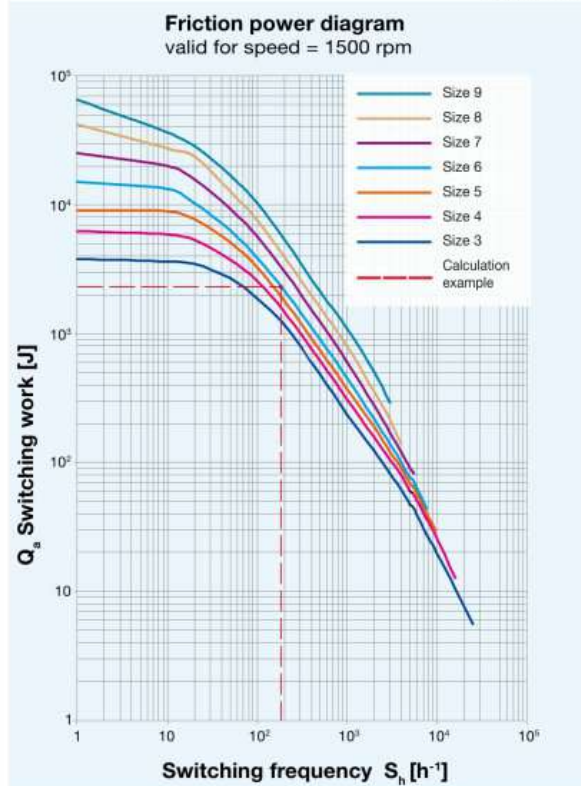

Diagram 2 (not valid for Type 500.30_)

Technical Explanations

ROBATIC®-electromagnetic clutch



Switching times

The switching times stated in Table 3 have been determined by comprehensive series of tests. They are valid for switching DC-side with nominal air gap and warm coil. Deviations depend on the respective installation situation, ambient temperatures, release path and the type of rectification with which the corresponding clutch is operated.

Switching times			Size						
			3	4	5	6	7	8	9
Without overexcitation	Type 500	t_{11} [sec]	0,010	0,015	0,020	0,030	0,045	0,050	0,060
		t_1 [sec]	0,045	0,065	0,080	0,150	0,200	0,350	0,400
		t_2 [sec]	0,012	0,020	0,045	0,060	0,090	0,095	0,130
With overexcitation	Type 500	t_{11} [sec]	0,003	0,005	0,007	0,010	0,015	0,020	0,035
		t_1 [sec]	0,025	0,035	0,040	0,075	0,100	0,170	0,235
		t_2 [sec]	0,010	0,012	0,012	0,020	0,025	0,050	0,060
Without overexcitation	Type 540	t_{11} [sec]	0,050	0,072	0,112	0,160	0,200	0,350	0,460
		t_1 [sec]	0,014	0,020	0,030	0,050	0,075	0,095	0,130
		t_2 [sec]	0,004	0,005	0,006	0,010	0,013	0,020	0,035
With overexcitation	Type 540	t_{11} [sec]	0,024	0,035	0,056	0,080	0,100	0,170	0,235
		t_1 [sec]	0,017	0,026	0,035	0,052	0,079	-	-
		t_2 [sec]	0,079	0,113	0,140	0,262	0,350	-	-
Without overexcitation	Type 500.3	t_{11} [sec]	0,010	0,016	0,036	0,048	0,072	-	-
		t_1 [sec]	0,005	0,009	0,012	0,017	0,026	-	-
		t_2 [sec]	0,044	0,061	0,070	0,131	0,175	-	-

Table 3

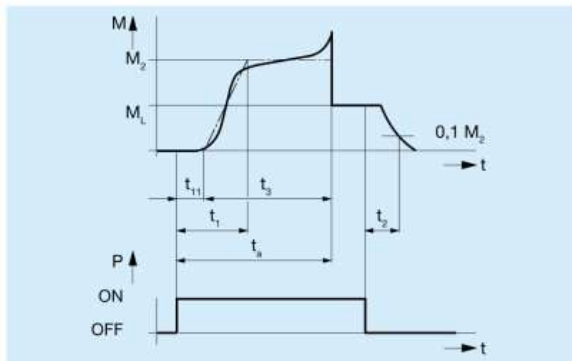

Key:

- M_2 = Nominal torque of the clutch
- M_L = Load torque of the drive
- P = Electrical power
- t_a = Acceleration time
- t_1 = Connection time
- t_{11} = Response delay on connection
- t_2 = Disconnection time
- t_3 = Slip time

Diagram 3: Torque-time

Friction work ¹⁾ and air gap			Size						
			3	4	5	6	7	8	9
Friction work up to 1 mm wear	Type 500	Q_1 [10 ⁷ J/mm]	12,5	20	33	57	100	105	170
	Type 540	Q_1 [10 ⁷ J/mm]	8,8	13,4	24	36	60	105	170
Total friction work	Type 500	Q_{tot} [10 ⁷ J]	12,5	25	50	100	200	185	340
	Type 540	Q_{tot} [10 ⁷ J]	8	16	35	68	135	185	340
Permitted friction work with a single switching		Q_E [10 ³ J]	3,8	6,2	9	15	25	42	65
Nominal air gap		a [mm]	0,2	0,2	0,2	0,3	0,3	0,5	0,5
Max. working air gap		a_n [mm]	0,6	0,8	1,0	1,2	1,5	1,8	2,0

Table 4

¹⁾ The friction work data are not valid for Type 500.30_0 double-flow design.

Please Observe!

Wear values can only be **recommended values** due to operating parameters, such as sliding speed, pressing or temperature.

Application

Rectifiers are used to connect DC consumers to alternating voltage supplies, for example electromagnetic brakes and clutches (ROBA-stop®, ROBA-quick®, ROBATIC®), electromagnets, electrovalves, contactors, switch-on safe DC motors, etc.

Function

The AC input voltage (VAC) is rectified (VDC) in order to operate DC voltage units. Also, voltage peaks, which occur when switching off inductive loads and which may cause damage to insulation and contacts, are limited and the contact load reduced.



Electrical Connection (Terminals)

- 1 + 2 Input voltage
- 3 + 4 Connection for an external switch for DC-side switching
- 5 + 6 Coil
- 7 - 10 Free nc terminals (only for Size 2)

Dimensions (mm)

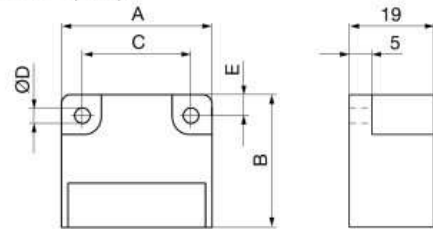

Size	A	B	C	ØD	E
1	34	30	25	3,5	4,5
2	54	30	44	4,5	5,0
3/4	64	30	54	4,5	5,0

Accessories: Mounting bracket set for 35 mm rail acc. EN 60715: Article-No. 1803201

Order Number

_	/	0	2	_	.	0	0	0	.	6
▲				▲						
Size				4						Half-wave rectifier
1				5						Bridge rectifier
up to										
4										

Technical Data

				Bridge rectifier		Half-wave rectifier				
Calculation output voltage				VDC = VAC x 0,9		VDC = VAC x 0,45				
Type				1/025	2/025	1/024	2/024	3/024	4/024	
Max. input voltage	± 10 %	U _{AC}	[VAC]	230	230	400	400	500	600	
Max. output voltage		U _{DC}	[VDC]	207	207	180	180	225	270	
Output current at	≤ 50°C	I _{RMS}	[A]	2,5	2,5	3,0	4,0	4,0	4,0	
	max. 85 °C	I _{RMS}	[A]	1,7	1,7	1,8	2,4	2,4	2,4	
Max. coil nominal capacity at	U _{AC} = 115 VAC	≤ 50 °C	P _{nom}	[W]	260	260	-	-	-	
		up to 85 °C	P _{nom}	[W]	177	177	-	-	-	
	U _{AC} = 230 VAC	≤ 50 °C	P _{nom}	[W]	517	517	312	416	416	
		up to 85 °C	P _{nom}	[W]	352	352	187	250	250	
	U _{AC} = 400 VAC	≤ 50 °C	P _{nom}	[W]	-	-	540	720	720	
		up to 85 °C	P _{nom}	[W]	-	-	324	432	432	
	U _{AC} = 500 VAC	≤ 50 °C	P _{nom}	[W]	-	-	-	-	900	
		up to 85 °C	P _{nom}	[W]	-	-	-	-	540	
	U _{AC} = 600 VAC	≤ 50 °C	P _{nom}	[W]	-	-	-	-	-	
		up to 85 °C	P _{nom}	[W]	-	-	-	-	648	
	Peak reverse voltage			[V]	1600	1600	2000	1600	2000	2000
	Rated insulation voltage		U _{RMS}	[V _{RMS}]	320	320	500	500	630	630
Pollution degree (insulation coordination)				1	1	1	1	1	1	
Device fuses				To be included in the input voltage line.						
Recommended microfuse switching capacity H	The microfuse corresponds to the max. possible connection capacity. If fuses are used corresponding to the actual capacities, the permitted limit integral I ² t must be observed on selection.			FF 3,15 A	FF 3,15 A	FF 4 A	FF 5 A	FF 5 A	FF 5 A	
Permitted limit integral	I ² t	[A ² s]		40	40	50	100	50	50	
Protection				IP65 components, encapsulated / IP20 terminals						
Terminals				Cross-section 0,14 - 1,5 mm ² (AWG 26-14)						
Ambient temperature		[°C]		- 25 up to + 85						
Storage temperature		[°C]		- 25 up to + 105						
Conformity markings				UL, CE	UL, CE	UL, CE	UL, CE	UL, CE	CE	
Installation conditions				The installation position can be user-defined. Please ensure sufficient heat dissipation and air convection! Do not install near to sources of intense heat!						

Spark Quenching Unit Type 070.000.6

Application

Reduces spark production on the switching contacts occurring during DC-side switching-off of inductive loads.

- Voltage limitation according to VDE 0580 2000-07, Item 4.6.
- Reduction of EMC-disturbance by voltage rise limitation, suppression of switching sparks.
- Reduction of brake engagement times by a factor of 2-4 compared to free-wheeling diodes.

Function

The spark quenching unit will absorb voltage peaks resulting from inductive load switching, which can cause damage to insulation and contacts. It limits these to 70 V and reduces the contact load. Switching products with a contact opening distance of > 3 mm are suitable for this purpose.



Electrical Connection (Terminals)

- 1 (+) Input voltage
- 2 (-) Input voltage
- 3 (-) Coil
- 4 (+) Coil
- 5 Free nc terminal
- 6 Free nc terminal

Dimensions (mm)

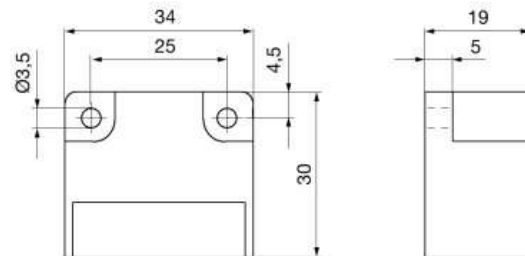

Technical Data

Input voltage	max. 300 VDC, max. 615 V _{peak} (rectified voltage 400 VAC, 50 / 60 Hz)
Switch-off energy	max. 9 J / 2 ms
Power dissipation	max. 0,1 Watt
Max. voltage nc terminals	250 V
Protection	IP65 / IP20 terminals
Ambient temperature	-25 °C up to +85 °C
Storage temperature	-25 °C up to +105 °C
Max. conductor connection diameter	2,5 mm ² / AWG 26-12
Max. terminal tightening torque	0,5 Nm

Accessories

Mounting bracket set for 35 mm rail acc. EN 60715:
Article-No. 1803201

Order Number

— / 0 7 0 . 0 0 0 . 6



Size
1

Exact positioning over the entire service lifetime

- ❑ **High torque security**
due to an optimised magnetic circuit and new design of the ROBA®-quick. Therefore higher capacities due to less magnetic leakage flux.
- ❑ **Exact positioning until wear limit**
ideal for positioning operations
- ❑ **Large internal diameters of the magnetic coil bodies**
Therefore large permitted shaft diameters and few magnetic field losses
- ❑ **Low noise**
- ❑ **Short switching times/high switching frequency**

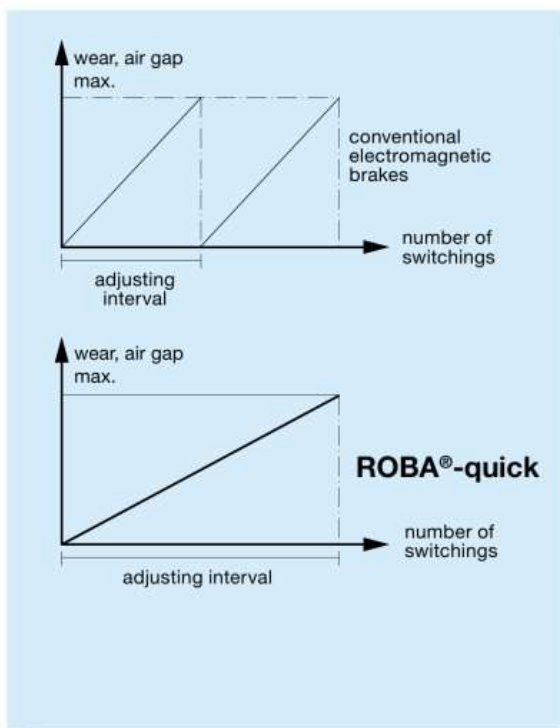
Functional principle

ROBA®-quick are "energise to engage", electromagnetic pole face brakes.

When DC voltage is applied to the magnetic coil (1), a magnetic field is built up. The armature disk (3) is attracted to the brake coil carrier (2) via friction lining (4). The brake torque runs from the coil carrier (2) via friction lining (4), armature disk (3) and membrane transmission spring (5) to the flange (6) and the shaft.

If the magnetic coil is de-energised, the membrane transmission spring (5) draws the armature disk (3) back to the flange (6). The brake is released and the shaft (7) can run freely.

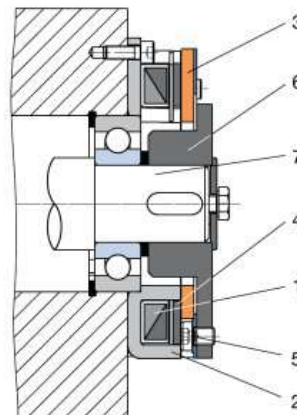

Summary of structural designs ROBA®-quick

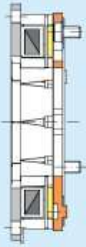
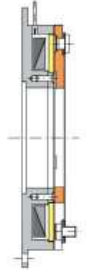
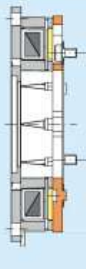
<p>ROBA®-quick standard</p> 	<p>Sizes 3 to 7 Type 520.20_0</p>	<table border="0"> <tr> <td>without accessories</td> <td>Type</td> <td>520.200.0</td> </tr> <tr> <td>flange hub</td> <td>Type</td> <td>520.201.0</td> </tr> <tr> <td>internal hub</td> <td>Type</td> <td>520.202.0</td> </tr> </table> <p style="text-align: right;">Pages 30 – 31</p>	without accessories	Type	520.200.0	flange hub	Type	520.201.0	internal hub	Type	520.202.0
without accessories	Type	520.200.0									
flange hub	Type	520.201.0									
internal hub	Type	520.202.0									
<p>ROBA®-quick standard</p> 	<p>Sizes 8 to 9 Type 520.1_0</p>	<table border="0"> <tr> <td>without accessories</td> <td>Type</td> <td>520.100</td> </tr> <tr> <td>flange hub</td> <td>Type</td> <td>520.110</td> </tr> <tr> <td>internal hub</td> <td>Type</td> <td>520.120</td> </tr> </table> <p style="text-align: right;">Pages 32 – 33</p>	without accessories	Type	520.100	flange hub	Type	520.110	internal hub	Type	520.120
without accessories	Type	520.100									
flange hub	Type	520.110									
internal hub	Type	520.120									
<p>ROBA®-quick small mounting diameter</p> 	<p>Sizes 3 to 7 Type 520.21_0</p>	<table border="0"> <tr> <td>without accessories</td> <td>Type</td> <td>520.210.0</td> </tr> <tr> <td>flange hub</td> <td>Type</td> <td>520.211.0</td> </tr> <tr> <td>internal hub</td> <td>Type</td> <td>520.212.0</td> </tr> </table> <p style="text-align: right;">Pages 34 – 35</p>	without accessories	Type	520.210.0	flange hub	Type	520.211.0	internal hub	Type	520.212.0
without accessories	Type	520.210.0									
flange hub	Type	520.211.0									
internal hub	Type	520.212.0									

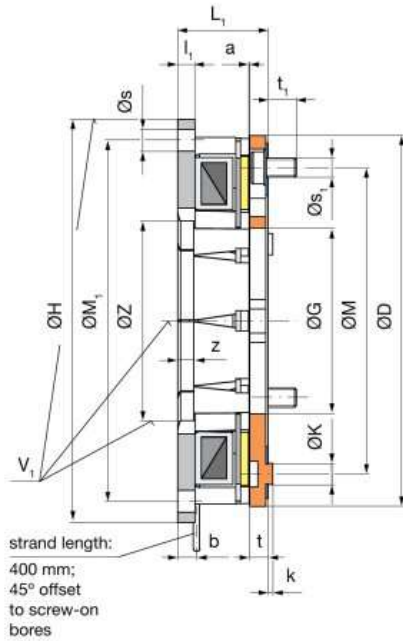

Type 520.200.0
Standard

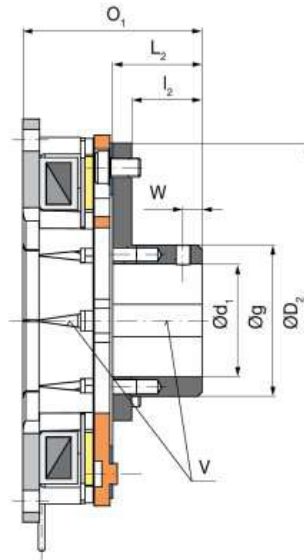

Type 520.201.0
Standard with flange hub

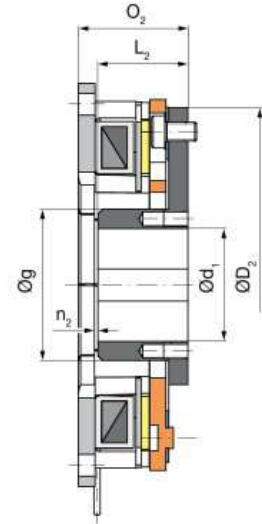

Type 520.202.0
Standard with internal hub

Order Number

_ / 5 2 0 . 2 0 _ . 0 / _ / _ / _						
▲			▲	▲	▲	▲
Sizes 3 to 7	without accessories	0	Coil voltage [VDC]	24 104	Hub * bore Ø d ₁ ^{H7}	Keyway * acc. DIN 6885/1 or DIN 6885/3
	flange hub	1				
	internal hub	2				

Example: 5 / 520.202.0 / 24 / 30 / DIN 6885/1

* Indication only with flange hub design or internal hub design.

ROBA®-quick electromagnetic brake

mayr®

Standard Sizes 3 – 7

Type 520.20_0

Technical Data				Size				
				3	4	5	6	7
Nominal torque ¹⁾	Type 520.20_0	M ₂	[Nm]	8,5	17	45	80	160
Electrical power		P ₂₀	[W]	13	20	31	47	71
Maximum speed		n _{max}	[rpm]	8600	7000	6100	5800	4500
Weight	without accessories	m	[kg]	0,38	0,55	1,25	1,88	3,5
	with flange hub	m	[kg]	0,42	0,86	1,40	2,35	7,5
Mass moment of inertia	Armature disk	I _{own}	[10 ⁻⁴ kgm ²]	0,76	1,92	6,86	17,56	52,86
	Flange hub ²⁾ + Armature disk	I _{own}	[10 ⁻⁴ kgm ²]	1,02	2,75	8,63	24,66	70,63

1) Please observe run-in regulations or minimum speed (see page 4).

2) With max. bore

Standard voltages 24 VDC; 104 VDC.
Permitted voltage tolerances acc. IEC 38 +/- 10 %.

Bores			Size				
			3	4	5	6	7
Ød ₁ ^{H7}	Preferred bores	[mm]	17; 20	20; 25	25; 30	30; 40	40; 50
	min.	[mm]	9	13	15	20	23
	max.	[mm]	20	30	35 ³⁾	45	60

3) Up to Ø 32 keyway acc. DIN 6885/1, above Ø 32 keyway acc. DIN 6885/3

Dimensions [mm]	Size				
	3	4	5	6	7
a	0,2	0,2	0,2	0,3	0,3
b	4,5	4	5,5	5,5	7,5
D	73,5	92	115	140	177
D ₂	70	88	110	140	170
G	36	49	57,5	74	95
g	29,5	44	47	66	84
H _{hb}	80	100	125	150	190
K	3 x 4,5	3 x 5,5	3 x 6,6	3 x 8,7	3 x 8,8
k	1,6	1,7	1,7	2,2	2,2
L ₁	22,1	24,7	28,1	31,4	34,7
L ₂	20	22	28	32	36
l ₁	3,5	4,3	5,2	6	7
l ₂	16	17	22	25	27
M	60	76	95	120	150

Dimensions [mm]	Size					
	3	4	5	6	7	
M ₁	72	90	112	137	175	
n ₂	2,6	3,2	1,1	0,3	1,7	
O ₁	42,1	46,7	56,1	63,4	70,7	
O ₂	26,1	29,7	34,1	38,3	43,7	
s	4 x 4,8	4 x 5,7	4 x 6,8	4 x 6,8	4 x 9,2	
s ₁	3 x M4	3 x M5	3 x M6	3 x M8	3 x M8	
t	3,9	4,5	5,8	7,1	8,3	
t ₁	5,2	7,2	8,7	8,0	9,7	
Permitted shaft misalignm. and centre offset	V	0,05	0,05	0,05	0,05	0,1
	V ₁	0,1	0,15	0,15	0,15	0,2
W	5	5	6	8	8	
Z ^{H8}	42	52	62	80	100	
z	3,5	4,5	5	6	6	

We reserve the right to make dimensional and constructional alterations.

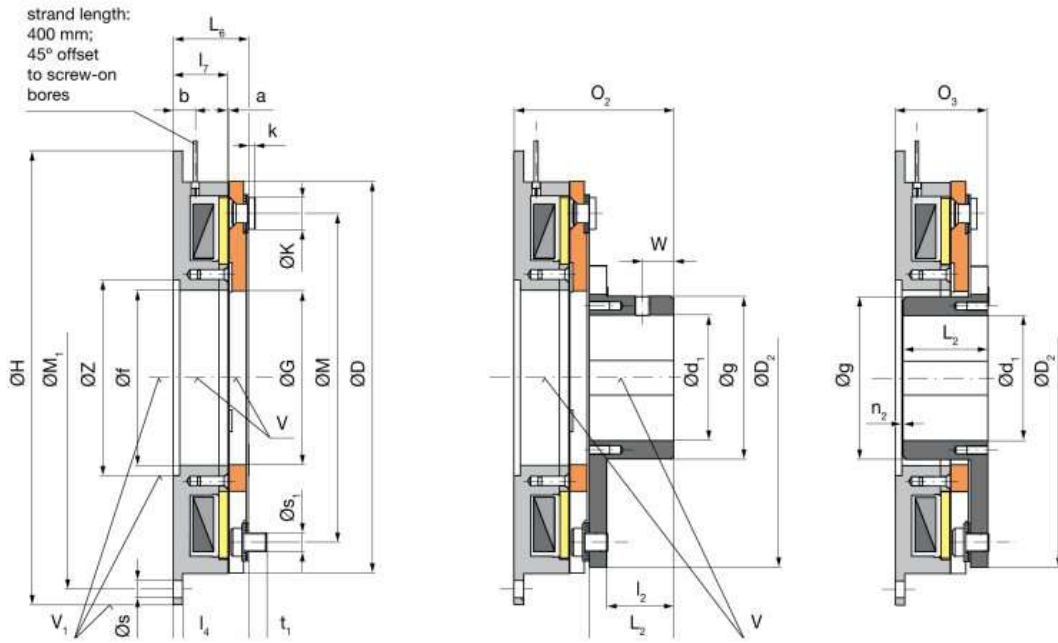

Type 520.100
Standard

Type 520.110
Standard with flange hub

Type 520.120
Standard with internal hub

Order Number

_ / 5 2 0 . 1 _ 0 / _ / _						
▲			▲	▲	▲	▲
Size		without accessories	0	Coil voltage [VDC]	24	Hub * bore $\varnothing d_1^{H7}$
8		flange hub	1	104		
9		internal hub	2			

Example: 8 / 520.110.0 / 24 / 40

* Indication only with flange hub design or internal hub design.

ROBA®-quick electromagnetic brake

mayr®

Standard

Sizes 8 – 9

Type 520.1_0

Technical Data				Size	
				8	9
Nominal torque ¹⁾	Type 520.1_0	M ₂	[Nm]	320	640
Electrical power		P ₂₀	[W]	40	77
Maximum speed		n _{max}	[rpm]	3000	2200
Weight	without accessories	m	[kg]	5,64	6,90
	with flange hub	m	[kg]	13,9	15,63
Mass moment of inertia	Armature disk	I _{own}	[10 ⁻⁴ kgm ²]	81	315
	Flange hub ²⁾ + Armature disk	I _{own}	[10 ⁻⁴ kgm ²]	107	381

1) Please observe run-in regulations or minimum speed (see page 4).

2) With max. bore

Standard voltages 24; 104 VDC.
Permitted voltage tolerances acc. IEC 38 +/- 10 %.

Bores			Size	
			8	9
Ød ₁ ^{H7}	Preferred bores	[mm]	40; 50	50; 60
	min.	[mm]	24	27
	max.	[mm]	60	80

Dimensions [mm]	Size	
	8	9
a	0,5	0,5
b	16	16
D	193	251
D ₂	185	242
f	92	112
G	91	111
g	84	104
H _{hb}	230	290
K	3 x 11,5	4 x 20
k	2	4,2
L ₂	45,3	53,9
L ₆	40,1	47,9
l ₂	36,3	42,9
l ₄	5	6

Dimensions [mm]	Size		
	8	9	
l ₇	30	35	
M	158	210	
M ₁	215	270	
n ₂	0,8	1,0	
O ₂	86,4	101,8	
O ₃	50,1	58,9	
s	4 x 9	4 x 11	
s ₁	3 x M10	4 x M12	
t ₁	8,5	11,8	
Permitted shaft mis-alignm. and centre offset	V	0,1	0,1
	V ₁	0,2	0,25
W	15	20	
Z ^{H8}	100	125	
z	4	4	

We reserve the right to make dimensional and constructional alterations.

Small mounting diameter

Sizes 3 – 7

Type 520.21_0

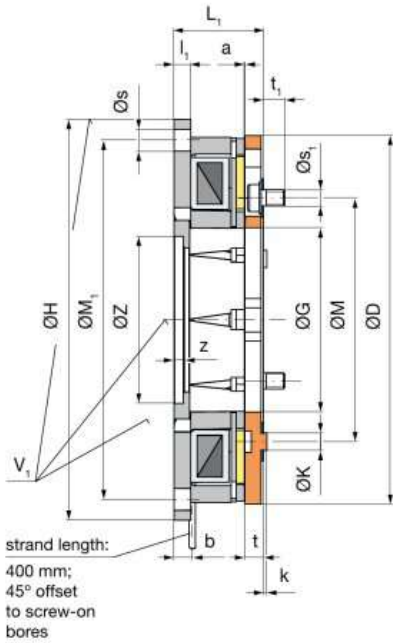

Type 520.210.0
Small mounting diameter

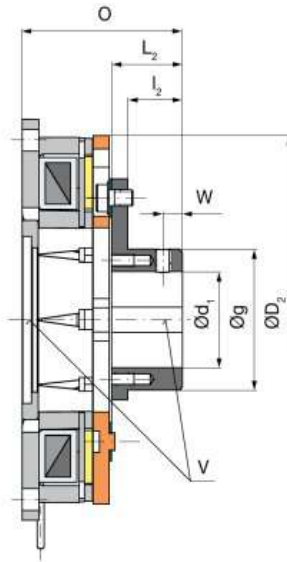

Type 520.211.0
Small mounting diameter
and flange hub

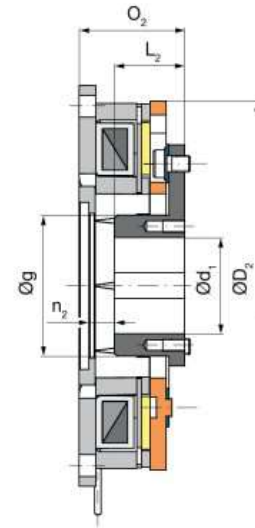

Type 520.212.0
Small mounting diameter
and internal hub

Order Number

_ / 5 2 0 . 2 1 _ . 0 / _ / _ / _							
▲				▲		▲	▲
Sizes 3 to 7		without accessories	0	Coil voltage [VDC]	24 104	Hub * bore Ø d ₁ H7	Keyway * acc. DIN 6885/1 or DIN 6885/3
		flange hub	1				
		internal hub	2				

Example: 6 / 520.212.0 / 24 / 35 / DIN 6885/3

* Indication only with flange hub design or internal hub design.

ROBA®-quick electromagnetic brake

mayr®

Small mounting diameter

Sizes 3 – 7

Type 520.21_0

Technical Data				Size				
				3	4	5	6	7
Nominal torque ¹⁾	Type 520.21_0	M ₂	[Nm]	8,5	17	45	80	160
Electrical power		P ₂₀	[W]	13	20	31	47	71
Maximum speed		n _{max}	[rpm]	8600	7000	6100	5800	4500
Weight	without accessories	m	[kg]	0,35	0,58	1,2	1,8	3,3
	with flange hub	m	[kg]	0,4	0,65	1,35	2	3,85
Mass moment of inertia	Armature disk	I _{own}	[10 ⁻⁴ kgm ²]	0,7	1,79	6,28	15,77	48,1
	Flange hub ²⁾ + Armature disk	I _{own}	[10 ⁻⁴ kgm ²]	0,8	1,97	7,19	17,54	55,2

1) Please observe run-in regulations or minimum speed (see page 4).

2) With max. bore

Standard voltages 24 VDC; 104 VDC.
Permitted voltage tolerances acc. IEC 38 +/- 10 %.

Bores			Size				
			3	4	5	6	7
Ød ₁ ^{H7}	Preferred bores	[mm]	10; 15	17; 20	20; 25	25; 30	30; 40
	min.	[mm]	9	10	13	15	20
	max.	[mm]	17	20	30	35 ³⁾	45

3) Up to Ø 32 keyway acc. DIN 6885/1, above Ø 32 keyway acc. DIN 6885/3

Dimensions [mm]	Size				
	3	4	5	6	7
a	0,2	0,2	0,2	0,3	0,3
b	4,5	4	5,5	5,5	7,5
D	73,5	92	115	140	177
D ₂	55	70	88	110	140
G	36	49	57,5	74	95
g	27	29,5	44	47	66
H _{hb}	80	100	125	150	190
K	3 x 3,5	3 x 4,5	3 x 5,5	3 x 6,6	3 x 8,8
k	1,6	1,7	2,3	2,7	2,7
L ₁	22,1	24,6	28,1	30,9	34,4
L ₂	15	20	22	28	32
l ₁	3,5	4,3	5,2	6	7
l ₂	11,5	16	17	22	25
M	46	60	76	95	120

Dimensions [mm]	Size					
	3	4	5	6	7	
M ₁	72	90	112	137	175	
n ₂	8,5	6,1	7,9	5,5	5,7	
O ₁	37,1	44,6	50,1	58,9	66,4	
O ₂	25,6	28,6	33,1	36,9	41,4	
s	4 x 4,8	4 x 5,7	4 x 6,8	4 x 6,8	4 x 9,2	
s ₁	3 x M3	3 x M4	3 x M5	3 x M6	3 x M8	
t	3,9	4,4	5,9	6,6	8,1	
t ₁	4,0	5,2	6,7	8,7	8,2	
Permitted shaft misalignm. and centre offset	V	0,05	0,05	0,05	0,05	0,1
	V ₁	0,1	0,15	0,15	0,15	0,2
W	5	5	6	8	8	
Z ^{H8}	35	42	52	62	80	
z	2	2,5	3	3,5	3,5	

We reserve the right to make dimensional and constructional alterations.

Installation Guidelines

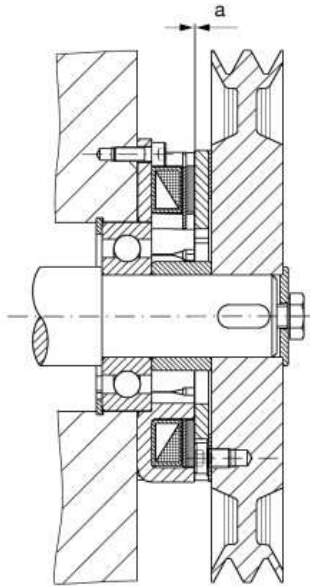

Fig. 1

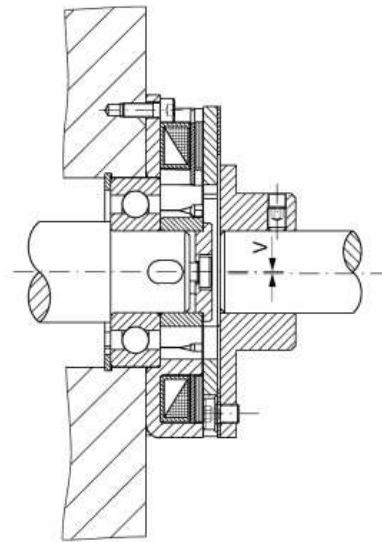

Fig. 2

	Size						
	3	4	5	6	7	8	9
a	0,2 ^{+0,1} _{-0,05}	0,2 ^{+0,15} _{-0,05}	0,2 ^{+0,15} _{-0,05}	0,3 ^{+0,15} _{-0,05}	0,3 ^{+0,15} _{-0,05}	0,5 ^{+0,15} _{-0,1}	0,5 ^{+0,15} _{-0,1}

Table 1 Adjustment of the air gaps

	Size						
	3	4	5	6	7	8	9
V	0,05	0,05	0,05	0,05	0,1	0,1	0,1

Table 2 Permitted shaft misalignments

The dimension "a" (Fig. 1) must be adjusted according to Table 1. Please ensure that the shaft is fastened axially, since otherwise the dimension "a" will change and cause the armature disk to band against coil carrier.

Design:

ROBA®-quick electromagnetic brakes are manufactured according to the electric protection IP 54 specification and the insulation material class F up to 155 °C for coil, moulding compound and connection strands as well as insulation class B +130 °C for the magnetic coil plastic-coated. The friction linings are asbestos-free, the surfaces of coil carrier and flange hub are phosphated. The armature disk is gas nitro-carburized and the transmission spring is made of stainless steel.

ROBA®-quick electromagnetic brakes are used for dry running. The torque is transmitted by friction between armature disk and the iron poles and the friction lining surfaces of the coil carrier.

When braking the eccentricity "V" according to Table must not be exceeded. The larger the displacement "V" the more the torque decreases and the hotter the friction surface becomes. In the case of arrangement according to table care must be taken that the coil carrier and shaft have no axial backlash since otherwise a brushing of the coil carrier would be possible. The flange hub is kept axially by means of a set screw (on set 90° to the key). The "V"-values are indicated again in the Technical Data of the individual brakes.

Please observe:

The run-in conditions or the min. speed must be observed (see page 4).

The friction surfaces have to be absolutely free of oil and grease as otherwise, the torque drops significantly. The air gap "a" (Fig. 1) has to be checked periodically. The brake does not function correctly if the max. working air gap (see Table 4, page 39) is exceeded.

Assembly and maintenance have to be carried out by well-trained specialists.

Brake size calculation

Formulas

1. Drive torque

$$M_A = \frac{9550 \times P_A}{n} \quad [\text{Nm}]$$

2. Required torque

$$M_{\text{req.}} \geq K \times M_A \quad [\text{Nm}]$$

3. Switchable torque of the brake (acc. to diagram 1, page 38)

$$M_S \geq M_{\text{req.}} \quad [\text{Nm}]$$

4. Mass moment of inertia

$$I = I_{\text{own}} + I_{\text{add.}} \quad [\text{kgm}^2]$$

5. Deceleration torque of the brake

$$M_v = M_S (+) M_L \quad [\text{Nm}]$$

6. Deceleration time

$$t_v = \frac{I \times n}{9,55 \times M_v} + t_1 \quad [\text{sec}]$$

7. Max. switching frequency per hour (dependent on time)

$$S_{h \text{ max}} = \frac{1}{t_{\text{aM}} + (t_v + t_2) \times 1,2} \times 3600 \quad [\text{h}^{-1}]$$

8. Friction work per deceleration

$$Q_v = \frac{I \times n^2}{182,4} \times \frac{M_S}{M_v} \quad [\text{J}]$$

9. Examination of the selected brake size in diagram 2 (page 38 friction power diagram).

Intersection friction work / switching frequency must be below the friction power curve! If it is above, the next size has to be selected and re-calculated from point 3 on.

$$Q_v < Q_E \quad [\text{J}]$$

10. Number of switchings until re-adjustment

$$Z_n = \frac{Q_1}{Q_v} \times (a_n - a) \quad [-]$$

11. Number of switchings until wear limit

$$Z = \frac{Q_{\text{tot.}}}{Q_v} \quad [-]$$

Key:

P_A	[kW]	drive power	
M_A	[Nm]	drive torque	
M_v	[Nm]	deceleration torque of the brake	
$M_{\text{req.}}$	[Nm]	required torque	
M_L	[Nm]	load torque (+ = drop load) (- = lift load)	
M_S	[Nm]	switchable torque of the brake (diagram 1, page 38)	
n	[rpm]	drive speed	
K		safety factor	≥ 2
I	[kgm ²]	mass moment of inertia	
I_{own}	[kgm ²]	own mass moment of inertia ("Technical data")	
$I_{\text{add.}}$	[kgm ²]	additional mass moment of inertia	
t_v	[sec]	deceleration time	
t_{aM}	[sec]	acceleration time of the machine	
t_1	[sec]	switch-on time of the brake	Table 3, page 39
t_2	[sec]	switch-off time of the brake	
$S_{h \text{ max}}$	[h ⁻¹]	max. switching frequency per hour (dependent on time)	
$Q_{\text{tot.}}$	[J]	total friction work (acc. Table 4, page 39)	
Q_v	[J]	friction work per deceleration	
Q_E	[J]	perm. friction work for single switching	Table 4, page 39
Q_1	[J/mm]	friction work until 1 mm wear	
Z_n		number of switchings until re-adjustment	
Z		number of switchings until wear limit	
a	[mm]	nominal air gap	Table 4, page 39
a_n	[mm]	max. working air gap	

Calculation example

Data:

Input power	P_A	= 3 kW
Input speed	n	= 1400 rpm
Load torque output	M_L	= 15 Nm
Additional mass moment of inertia	$I_{add.}$	= 0,15 kgm ²
Acceleration time of the machine	t_{aM}	= 1,5 [sec]
350 switchings per hour		

Drive torque

$$M_A = \frac{9550 \times P_A}{n} = \frac{9550 \times 3}{1400} = 20,5 \text{ [Nm]}$$

Required torque

$$M_{req.} = K \times M_A = 2 \times 20,5 = 41 \text{ [Nm]}$$

Determined brake size (acc. to diagram 1) = Size 6

$$M_S \geq M_{req.} = 47 \text{ [Nm]}$$

selected brake = Size 6, Type 520.200.0

Mass moment of inertia

$$I = I_{own} + I_{add.} = 0,001756 + 0,15 = 0,151756 \text{ [kgm}^2\text{]}$$

Deceleration torque of the brake

$$M_v = M_S + M_L = 47 + 15 = 62 \text{ [Nm]}$$

Deceleration time of the brake

$$t_v = \frac{I \times n}{9,55 \times M_v} + t_1^* = \frac{0,151756 \times 1400}{9,55 \times 62} + 0,10 = 0,46 \text{ [sec]}$$

* Switching times t_1 and t_2 from Table 3, page 25 = without overexcitation

Max. switching frequency per hour

$$S_{n \max} = \frac{1}{t_{aM} + (t_v + t_2^*) \times 1,2} \times 3600$$

$$S_{n \max} = \frac{1}{1,5 + (0,46 + 0,060) \times 1,2} \times 3600 = 1695 \text{ [h}^{-1}\text{]}$$

Friction work per deceleration

$$Q_v = \frac{I \times n^2}{182,4} \times \frac{M_S}{M_v}$$

$$Q_v = \frac{0,151756 \times 1400^2}{182,4} \times \frac{47}{62} = 1236 \text{ [J]} \leq Q_E$$

The point of intersection determined in diagram 2 must be located in or under the characteristic curve of the selected brake.

Switching frequency: 350 switchings per hour = permitted

Number of switchings until adjustment

$$Z_n = \frac{Q_i}{Q_v} \times (a_n - a)$$

$$Z_n = \frac{57 \times 10^7}{1236} \times (1,2 - 0,3) = 415048 \text{ switchings}$$

Number of switchings until wear limit

$$Z = \frac{Q_{tot.}}{Q_v} = \frac{100 \times 10^7}{1236} = 809061 \text{ switchings}$$

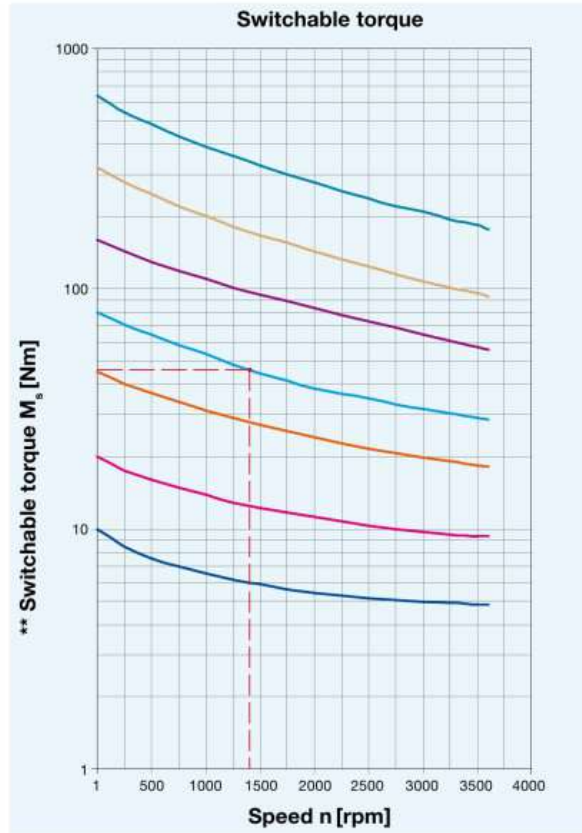

Diagram 1 ** Friction surfaces have been run in

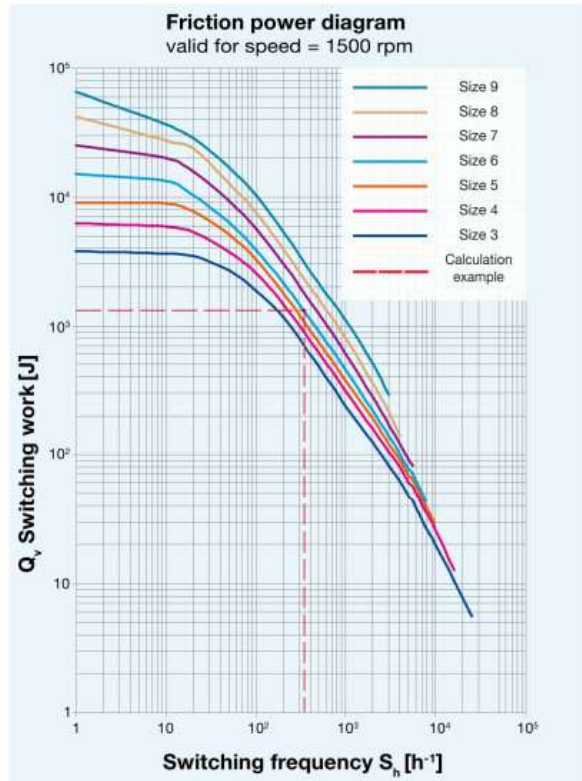

Diagram 2

Technical Explanations

ROBA®-quick electromagnetic brake



Switching times

The switching times stated in Table 3 have been determined by comprehensive series of tests. They are valid for switching DC-side with nominal air gap and warm coil. Deviations depend on the respective installation situation, ambient temperatures, release path and the type of rectification with which the corresponding brake is operated.

Switching times			Size						
			3	4	5	6	7	8	9
Without overexcitation	Type 520	t_{11} [sec]	0,006	0,008	0,010	0,015	0,025	0,027	0,030
		t_1 [sec]	0,035	0,040	0,055	0,100	0,150	0,245	0,330
		t_2 [sec]	0,010	0,018	0,030	0,060	0,090	0,100	0,140
With overexcitation	Type 520	t_{11} [sec]	0,002	0,003	0,004	0,006	0,008	0,010	0,015
		t_1 [sec]	0,020	0,022	0,030	0,050	0,075	0,120	0,165

Table 3

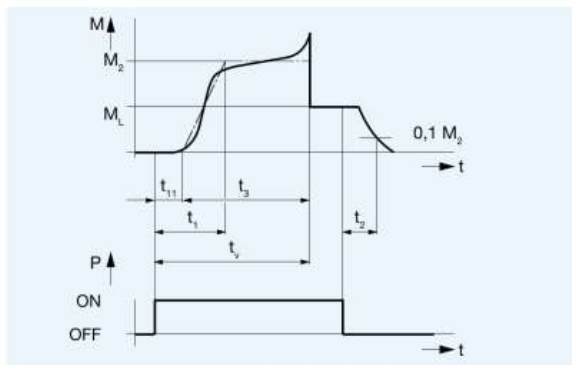

Key:

- M_2 = Nominal torque of the brake
- M_L = Load torque of the drive
- P = Electrical power
- t_v = Deceleration time
- t_1 = Connection time
- t_{11} = Response delay on connection
- t_2 = Disconnection time
- t_3 = Slip time

Diagram 3: Torque-time

Friction work and air gap			Size						
			3	4	5	6	7	8	9
Friction work up to 1 mm wear	Type 520	Q_1 [10^7 J/mm]	12,5	20	33	57	100	105	170
Total friction work	Type 520	Q_{tot} [10^7 J]	12,5	25	50	100	200	185	340
Permitted friction work with a single switching		Q_E [10^3 J]	3,8	6,2	9	15	25	42	65
Nominal air gap		a [mm]	0,2	0,2	0,2	0,3	0,3	0,5	0,5
Max. working air gap		a_n [mm]	0,6	0,8	1,0	1,2	1,5	1,8	2,0

Table 4

Please Observe!

Wear values can only be **recommended values** due to operating parameters, such as sliding speed, pressing or temperature.

Application

Rectifiers are used to connect DC consumers to alternating voltage supplies, for example electromagnetic brakes and clutches (ROBA-stop®, ROBA-quick®, ROBATIC®), electromagnets, electrovalves, contactors, switch-on safe DC motors, etc.

Function

The AC input voltage (VAC) is rectified (VDC) in order to operate DC voltage units. Also, voltage peaks, which occur when switching off inductive loads and which may cause damage to insulation and contacts, are limited and the contact load reduced.



Electrical Connection (Terminals)

- 1 + 2 Input voltage
- 3 + 4 Connection for an external switch for DC-side switching
- 5 + 6 Coil
- 7 - 10 Free nc terminals (only for Size 2)

Dimensions (mm)

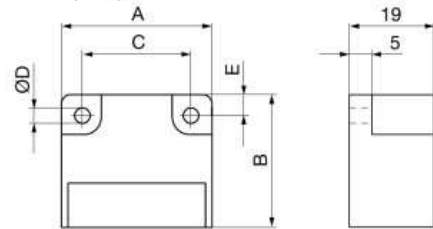

Size	A	B	C	ØD	E
1	34	30	25	3,5	4,5
2	54	30	44	4,5	5,0
3/4	64	30	54	4,5	5,0

Accessories: Mounting bracket set for 35 mm rail acc. EN 60715: Article-No. 1803201

Order Number

—	/	0	2	—	.	0	0	0	.	6
▲				▲						
Size				4						Half-wave rectifier
1				5						Bridge rectifier
up to										
4										

Technical Data

				Bridge rectifier		Half-wave rectifier				
Calculation output voltage				VDC = VAC x 0,9		VDC = VAC x 0,45				
Type				1/025	2/025	1/024	2/024	3/024	4/024	
Max. input voltage	± 10 %	U _{AC}	[VAC]	230	230	400	400	500	600	
Max. output voltage		U _{DC}	[VDC]	207	207	180	180	225	270	
Output current at	≤ 50 °C	I _{RMS}	[A]	2,5	2,5	3,0	4,0	4,0	4,0	
	max. 85 °C	I _{RMS}	[A]	1,7	1,7	1,8	2,4	2,4	2,4	
Max. coil nominal capacity at	U _{AC} = 115 VAC	≤ 50 °C	P _{nom}	[W]	260	260	-	-	-	-
		up to 85 °C	P _{nom}	[W]	177	177	-	-	-	-
	U _{AC} = 230 VAC	≤ 50 °C	P _{nom}	[W]	517	517	312	416	416	416
		up to 85 °C	P _{nom}	[W]	352	352	187	250	250	250
	U _{AC} = 400 VAC	≤ 50 °C	P _{nom}	[W]	-	-	540	720	720	720
		up to 85 °C	P _{nom}	[W]	-	-	324	432	432	432
	U _{AC} = 500 VAC	≤ 50 °C	P _{nom}	[W]	-	-	-	-	900	900
		up to 85 °C	P _{nom}	[W]	-	-	-	-	540	540
	U _{AC} = 600 VAC	≤ 50 °C	P _{nom}	[W]	-	-	-	-	-	1080
		up to 85 °C	P _{nom}	[W]	-	-	-	-	-	648
	Peak reverse voltage			[V]	1600	1600	2000	1600	2000	2000
	Rated insulation voltage		U _{RMS}	[V _{RMS}]	320	320	500	500	630	630
Pollution degree (insulation coordination)				1	1	1	1	1	1	
Device fuses				To be included in the input voltage line.						
Recommended microfuse switching capacity H	The microfuse corresponds to the max. possible connection capacity. If fuses are used corresponding to the actual capacities, the permitted limit integral I ² t must be observed on selection.			FF 3,15 A	FF 3,15 A	FF 4 A	FF 5 A	FF 5 A	FF 5 A	
Permitted limit integral	I ² t	[A ² s]		40	40	50	100	50	50	
Protection				IP65 components, encapsulated / IP20 terminals						
Terminals				Cross-section 0,14 - 1,5 mm ² (AWG 26-14)						
Ambient temperature		[°C]		- 25 up to + 85						
Storage temperature		[°C]		- 25 up to + 105						
Conformity markings				UL, CE	UL, CE	UL, CE	UL, CE	UL, CE	CE	
Installation conditions				The installation position can be user-defined. Please ensure sufficient heat dissipation and air convection! Do not install near to sources of intense heat!						

Spark Quenching Unit Type 070.000.6

Application

Reduces spark production on the switching contacts occurring during DC-side switching-off of inductive loads.

- Voltage limitation according to VDE 0580 2000-07, Item 4.6.
- Reduction of EMC-disturbance by voltage rise limitation, suppression of switching sparks.
- Reduction of brake engagement times by a factor of 2-4 compared to free-wheeling diodes.

Function

The spark quenching unit will absorb voltage peaks resulting from inductive load switching, which can cause damage to insulation and contacts. It limits these to 70 V and reduces the contact load. Switching products with a contact opening distance of > 3 mm are suitable for this purpose.



Electrical Connection (Terminals)

- 1 (+) Input voltage
- 2 (-) Input voltage
- 3 (-) Coil
- 4 (+) Coil
- 5 Free nc terminal
- 6 Free nc terminal

Dimensions (mm)

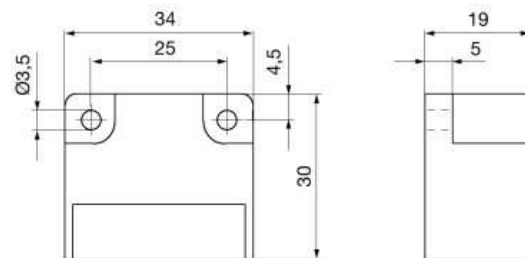

Technical Data

Input voltage	max. 300 VDC, max. 615 V _{peak} (rectified voltage 400 VAC, 50 / 60 Hz)
Switch-off energy	max. 9 J / 2 ms
Power dissipation	max. 0,1 Watt
Max. voltage nc terminals	250 V
Protection	IP65 / IP20 terminals
Ambient temperature	-25 °C up to +85 °C
Storage temperature	-25 °C up to +105 °C
Max. conductor connection diameter	2,5 mm ² / AWG 26-12
Max. terminal tightening torque	0,5 Nm

Accessories

Mounting bracket set for 35 mm rail acc. EN 60715:
Article-No. 1803201

Order Number

— / 0 7 0 . 0 0 0 . 6



Size
1

The clutch brake module for positioning and synchronising

- ❑ Energy-saving and environmentally-friendly
- ❑ Positioning accuracy for the entire service lifetime
- ❑ High switching frequency
- ❑ Maintenance-free during the entire service lifetime
- ❑ Low-noise
- ❑ Sealed
- ❑ Individual variants
 - without flange
 - with cast IEC-flange
 - with hollow shaft

Maintenance-free/ no manual re-adjustment

- Constant switching behaviour, i.e. high positioning accuracy and freedom maintenance over the entire service lifetime
- No downtime due to re-adjustment

High radial shaft end loads

Strengthened bearings

- High radial loads of the input and output shafts permitted

Heat dissipation

Optimized heat dissipation and large cooling ribs operational

- Optimum operation temperature due to dissipation of the frictional heat
- Constant characteristic operating data

Low leakage flux/ high friction power

Larger magnetic and friction surfaces (asbestos free) with the same dimensions due to the new technology of the clutches and brakes

- Optimised electromagnetic effect, i.e. low leakage flux, faster switching behaviour, less heat build-up and, therefore, constant holding accuracy



Sturdy housing

Consists of en bloc cast two part ribbed housing, in a flanged design with cast flanges

- Large housing rigidity guarantees dimensional stability, even with loads not caused under regular conditions (for example weight load by people)

Functional Principle

The **ROBA®-takt** clutch brake module is an electromagnetic clutch brake unit. Whilst the drive machine runs through continuously, it generates cycle operation via alternating coupling and braking actions.

ROBA®-takt clutch brake modules guarantee high cycle times.

Due to the completely enclosed construction (Protection IP55), conceived acc. VDE/IEC directives, the **ROBA®-takt** clutch brake module is ideal for all standardized motors and gearboxes.



This means that many different installation positions are possible.

Due to the patented principle of self-readjustment, the **ROBA®-takt** clutch brake module is accurately positioned and maintenance-free over the entire service lifetime.

ROBA®-takt clutch brake module

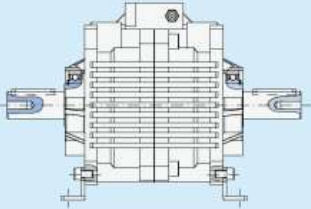
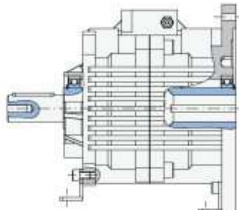

Summary of structural designs ROBA®-takt

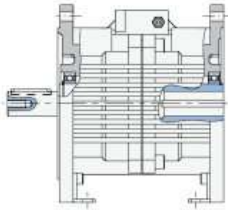
<p>ROBA®-takt</p>  <p>without flange/shaft without flange/shaft</p>	<p>Sizes 3 to 7 Type 674.0_4.0</p>	<p>without feet Type 674.004.0 with feet Type 674.014.0</p> <p style="text-align: right;">Pages 44 – 45</p>
<p>ROBA®-takt</p>  <p>without flange/shaft IEC-flange/hollow shaft</p>	<p>Sizes 3 to 7 Type 674.0__0</p>	<p>without feet IEC-flange small Type 674.005.0 IEC-flange large Type 674.006.0</p> <p>with feet IEC-flange small Type 674.015.0 IEC-flange large Type 674.016.0</p> <p style="text-align: right;">Pages 46 – 47</p>
<p>ROBA®-takt</p>  <p>IEC-flange/shaft without flange/shaft</p>	<p>Sizes 3 to 7 Type 67_0_4.0</p>	<p>without feet IEC-flange small Type 675.004.0 IEC-flange large Type 676.004.0</p> <p>with feet IEC-flange small Type 675.014.0 IEC-flange large Type 676.014.0</p> <p style="text-align: right;">Pages 48 – 49</p>
<p>ROBA®-takt</p>  <p>IEC-flange/shaft IEC-flange/hollow shaft</p>	<p>Sizes 3 to 7 Type 67_0__0</p>	<p>without feet IEC-flange small/small Type 675.005.0 IEC-flange small/large Type 675.006.0 IEC-flange large/small Type 676.005.0 IEC-flange large/large Type 676.006.0</p> <p>with feet IEC-flange small/small Type 675.015.0 IEC-flange small/large Type 675.016.0 IEC-flange large/small Type 676.015.0 IEC-flange large/large Type 676.016.0</p> <p style="text-align: right;">Pages 50 – 51</p>

Additional designs are available on request.

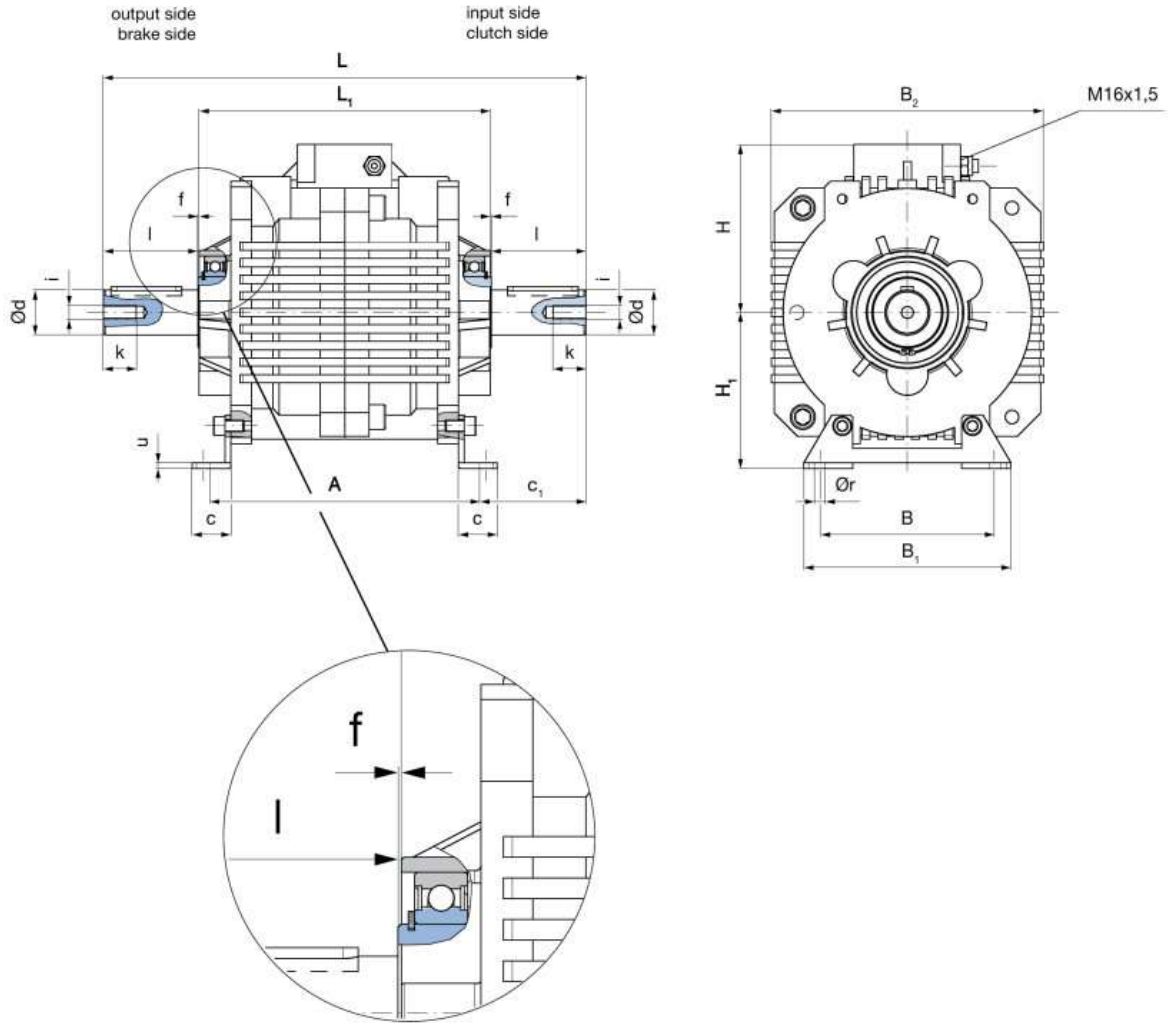

Order Number

<p>__ / 6 7 4 . 0 __ 4 . 0 / __ / W__ / W__</p>								with control unit
▲			▲		▲	▲	▲	▲
Sizes 3 to 7	without feet	0	Coil voltage [VDC]	24	output * shaft Ø d _{k6}	input * shaft Ø d _{k6}	see pages 56 - 58	
	with feet	1		104				

Example: 5 / 674.014.0 / 24 / W24 / W24

* Special dimensions on request

ROBA®-takt clutch brake module

mayr®

Sizes 3 – 7

Type 674.0_4.0

Technical Data				Size				
				3	4	5	6	7
Nominal torque	Clutch	M_2	[Nm]	10	20	45	80	160
	Brake	M_2	[Nm]	8,5	17	45	80	160
Electrical power	Clutch	P_{20}	[W]	17	25	30	44	79
	Brake	P_{20}	[W]	13	23	30	45	70
Maximum speed		n_{max}	[rpm]	3600	3600	3600	3600	3600
Weight	Type 674.014.0	m	[kg]	3,9	6,8	9,9	15,3	27,7
Mass moment of inertia	Output Type 674.014.0	I	[10 ⁻⁴ kgm ²]	2,5	6,37	21,5	60,5	138

Standard voltage 24 VDC; 104 VDC.
Permitted voltage tolerances acc. IEC 38 +/-10 %.

Dimensions [mm]	Size				
	3	4	5	6	7
A	126	146	165	189	233
B	75	95	110	120	145
B ₁	93	115	136	152	175
B ₂	114	127	156	179	230
c	19	22	28	28	33
c ₁	37	46,5	57	67	89
d _{K6}	14	19	24	28	38
f	1	1	1	1	1
H	86	94	106	121	142

Dimensions [mm]	Size				
	3	4	5	6	7
H ₁	63	80	90	100	132
i	M5	M6	M8	M10	M12
k	12,5	16	19	22	28
L	200	239	279	323	408
L ₁	138	157	177	201	246
l	30	40	50	60	80
r	6,6	9	11	11	14
u	3	3	4	4	5

We reserve the right to make dimensional and constructional alterations.

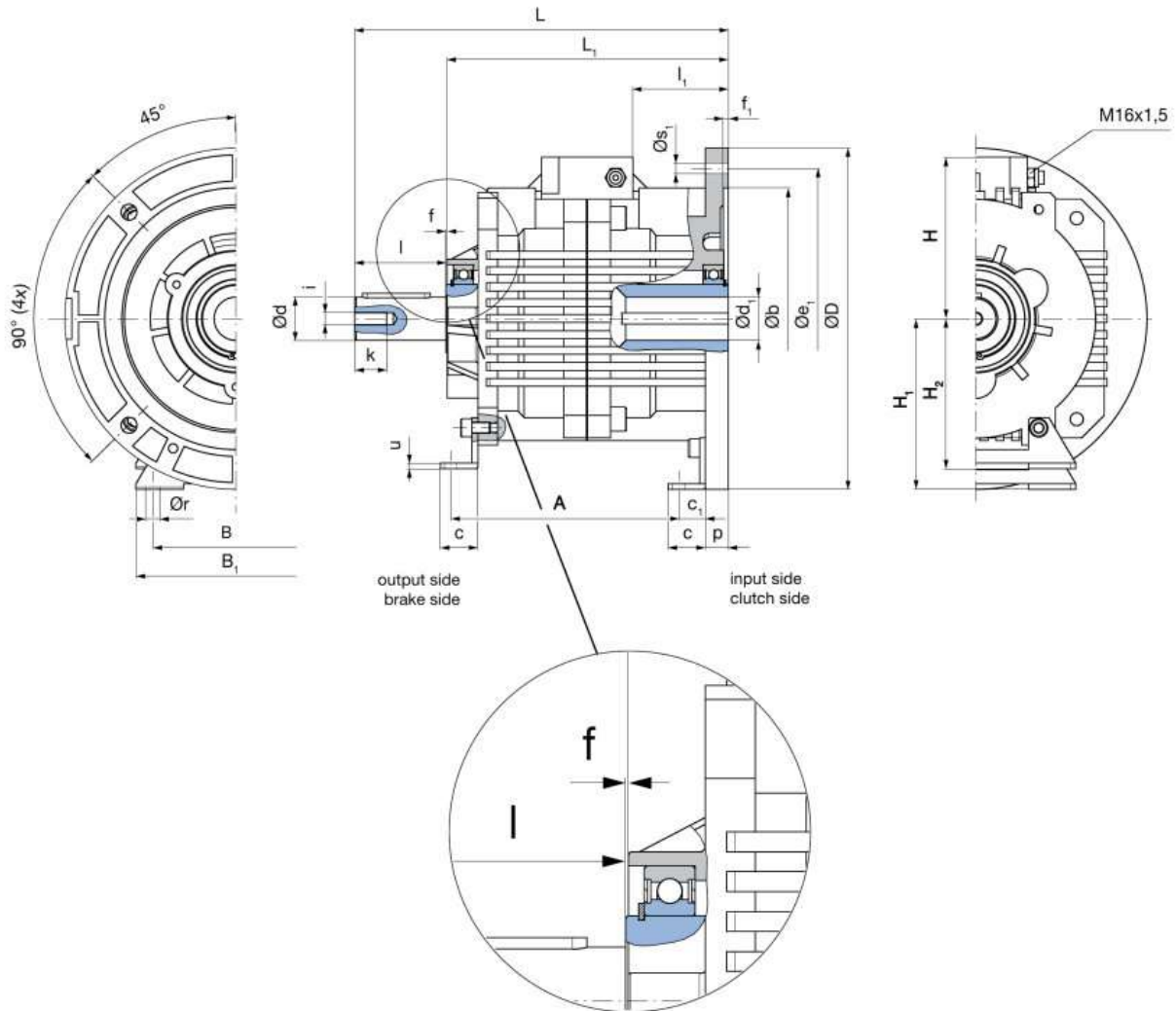

Order Number

Clutch side							
IEC-flange small 5							
IEC-flange large 6							
▼							
__ / 6 7 4 . 0 __ . 0 / __ / W__ / B__							
with control unit							
▲ ▲ ▲ ▲ ▲ ▲ ▲							
Sizes 3 to 7	without feet	0	Coil voltage [VDC]	24	output shaft *	input hollow shaft bore *	see pages 56 - 58
	with feet	1		104	Ø d _{KB}	Ø d _{FB}	

ROBA®-takt clutch brake module

mayr®

Sizes 3 – 7

Type 674.0__0

Technical Data				Size				
				3	4	5	6	7
Nominal torque	Clutch	M_2	[Nm]	10	20	45	80	160
	Brake	M_2	[Nm]	8,5	17	45	80	160
Electrical power	Clutch	P_{20}	[W]	17	25	30	44	79
	Brake	P_{20}	[W]	13	23	30	45	70
Maximum speed		n_{max}	[rpm]	3600	3600	3600	3600	3600
Weight	Type 674.014.0	m	[kg]	3,9	6,8	9,9	15,3	27,7
Mass moment of inertia	Output Type 674.014.0	I	[10 ⁻⁴ kgm ²]	2,5	6,37	21,5	60,5	138

Standard voltage 24 VDC; 104 VDC.
Permitted voltage tolerances acc. IEC 38 +/-10 %.

Dimensions IEC [mm]	Size									
	3		4		5		6		7	
optionally with small or large IEC-flange	IEC-small	IEC-large	IEC-small	IEC-large	IEC-small	IEC-large	IEC-small	IEC-large	IEC-small	IEC-large
D	140	160	160	200	200	200	200	250	250	300
d_1^{FB}	11	14	14	19	19	24	24	28	28	38
$b^{+0,5}_{-0,3}$	95	110	110	130	130	130	130	180	180	230
e_1	115	130	130	165	165	165	165	215	215	265
f_1	3,5	4	4	4	4	4	4	4,5	4,5	4,5
$H_1^{1)}$	70	80	80	100	100	100	100	125	125	150
l_1	25	32	32	42	42	55	55	65	65	90
s_1	9	9	9	11	11	11	11	14	14	14

Dimensions [mm]	Size				
	3	4	5	6	7
A	110	126	140	164	198
B	75	95	110	120	145
B_1	93	115	136	152	175
c	19	22	28	28	33
c_1	11	13,5	18	18	21
d_{kb}	14	19	24	28	38
f	1	1	1	1	1
H	86	94	106	121	142
$H_2^{1)}$	63	80	90	100	132

Dimensions [mm]	Size				
	3	4	5	6	7
i	M5	M6	M8	M10	M12
k	12,5	16	19	22	28
L	170	199	229	263	328
L_1	139	158	178	202	247
l	30	40	50	60	80
p	12	13	14	14	20
r	6,6	9	11	11	14
u	3	3	4	4	5

We reserve the right to make dimensional and constructional alterations.

1) Please observe the difference in height of the feet input side and output side.

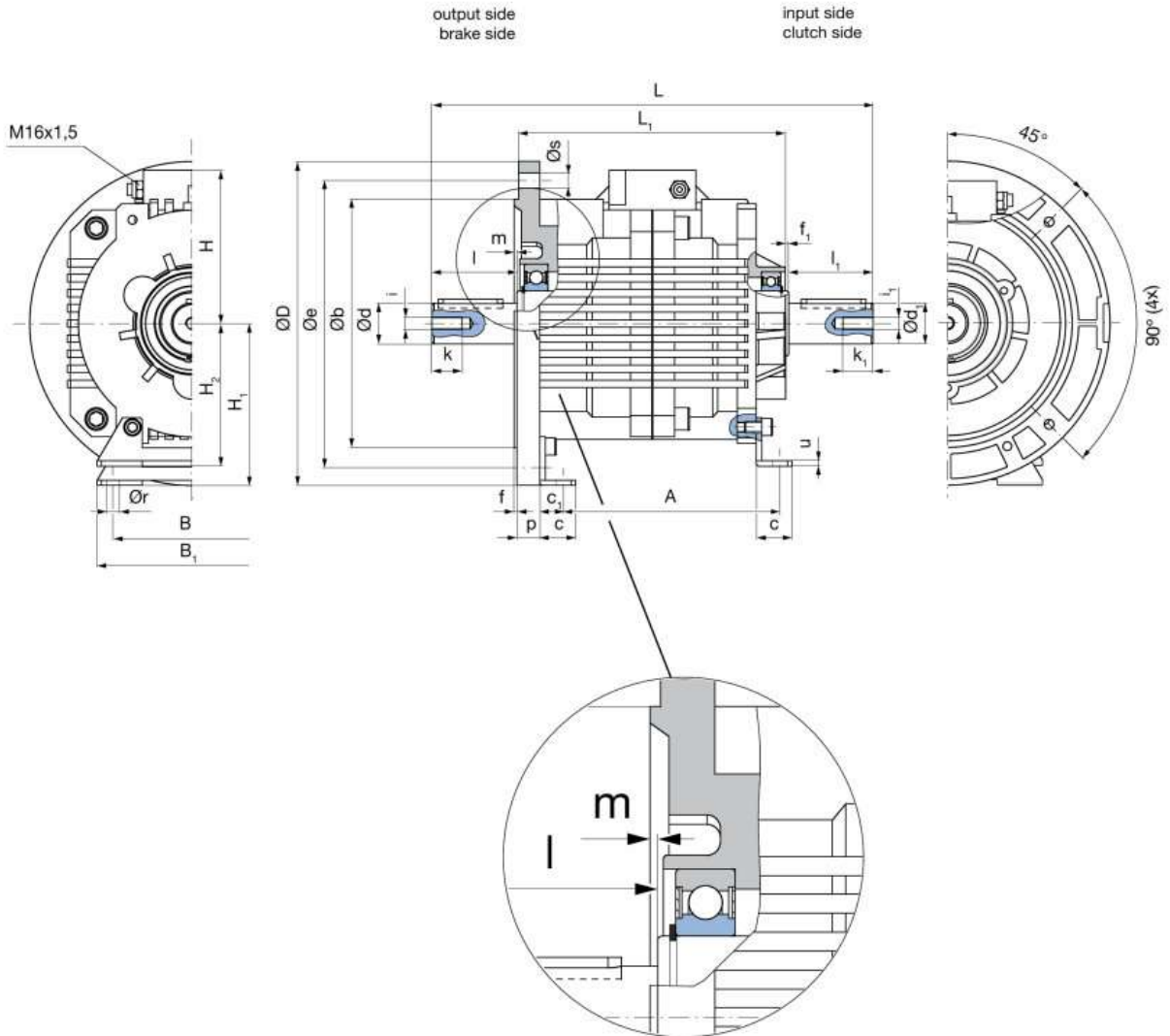

Order Number

Brake side

- IEC-flange small 5
- IEC-flange large 6



_	/ 6 7	_ . 0	_	4 . 0 /	_ / W	_ / W	with control unit
▲			▲		▲	▲	▲
Sizes 3 to 7	without feet with feet	0 1	Coil voltage [VDC]	24 104	output shaft * $\text{Ø } d_{kb}$	input shaft * $\text{Ø } d_{1 kb}$	see pages 56 - 58

ROBA®-takt clutch brake module

mayr®

Sizes 3 – 7

Type 67_0_0_0

Technical Data				Size				
				3	4	5	6	7
Nominal torque	Clutch	M_2	[Nm]	10	20	45	80	160
	Brake	M_2	[Nm]	8,5	17	45	80	160
Electrical power	Clutch	P_{20}	[W]	17	25	30	44	79
	Brake	P_{20}	[W]	13	23	30	45	70
Maximum speed		n_{max}	[rpm]	3600	3600	3600	3600	3600
Weight	Type 674.014.0	m	[kg]	3,9	6,8	9,9	15,3	27,7
Mass moment of inertia	Output Type 674.014.0	I	[10 ⁻⁴ kgm ²]	2,5	6,37	21,5	60,5	138

Standard voltage 24 VDC; 104 VDC.
Permitted voltage tolerances acc. IEC 38 +/-10 %.

Dimensions IEC [mm]	Size									
	3		4		5		6		7	
optionally with small or large IEC-flange	IEC-small	IEC-large	IEC-small	IEC-large	IEC-small	IEC-large	IEC-small	IEC-large	IEC-small	IEC-large
D	140	160	160	200	200	200	200	250	250	300
d_{k6}	11	14	14	19	19	24	24	28	28	38
b_{j6}	95	110	110	130	130	130	130	180	180	230
e	115	130	130	165	165	165	165	215	215	265
f	3	3,5	3,5	3,5	3,5	3,5	3,5	4	4	4
$H_1^{1)}$	70	80	80	100	100	100	100	125	125	150
i	M4	M5	M5	M6	M6	M8	M8	M10	M10	M12
k	10	12,5	12,5	16	16	19	19	22	22	28
L	193	200	229	239	269	279	313	323	388	408
l	23	30	30	40	40	50	50	60	60	80
m	3	3,5	3,5	3,5	3,5	3,5	3,5	4	4	4
s	9	9	9	11	11	11	11	14	14	14

Dimensions [mm]	Size				
	3	4	5	6	7
A	110	126	140	164	198
B	75	95	110	120	145
B_1	93	115	136	152	175
c	19	22	28	28	33
c_1	11	13,5	18	18	21
$d_{1 k6}$	14	19	24	28	38
f_1	1	1	1	1	1
H	86	94	106	121	142

1) Please observe the difference in height of the feet input side and output side.

Dimensions [mm]	Size				
	3	4	5	6	7
$H_2^{1)}$	63	80	90	100	132
i_1	M5	M6	M8	M10	M12
k_1	12,5	16	19	22	28
L_1	139	158	178	202	247
l_1	30	40	50	60	80
p	12	13	14	14	20
r	6,6	9	11	11	14
u	2,5	3	3	3	4

We reserve the right to make dimensional and constructional alterations.

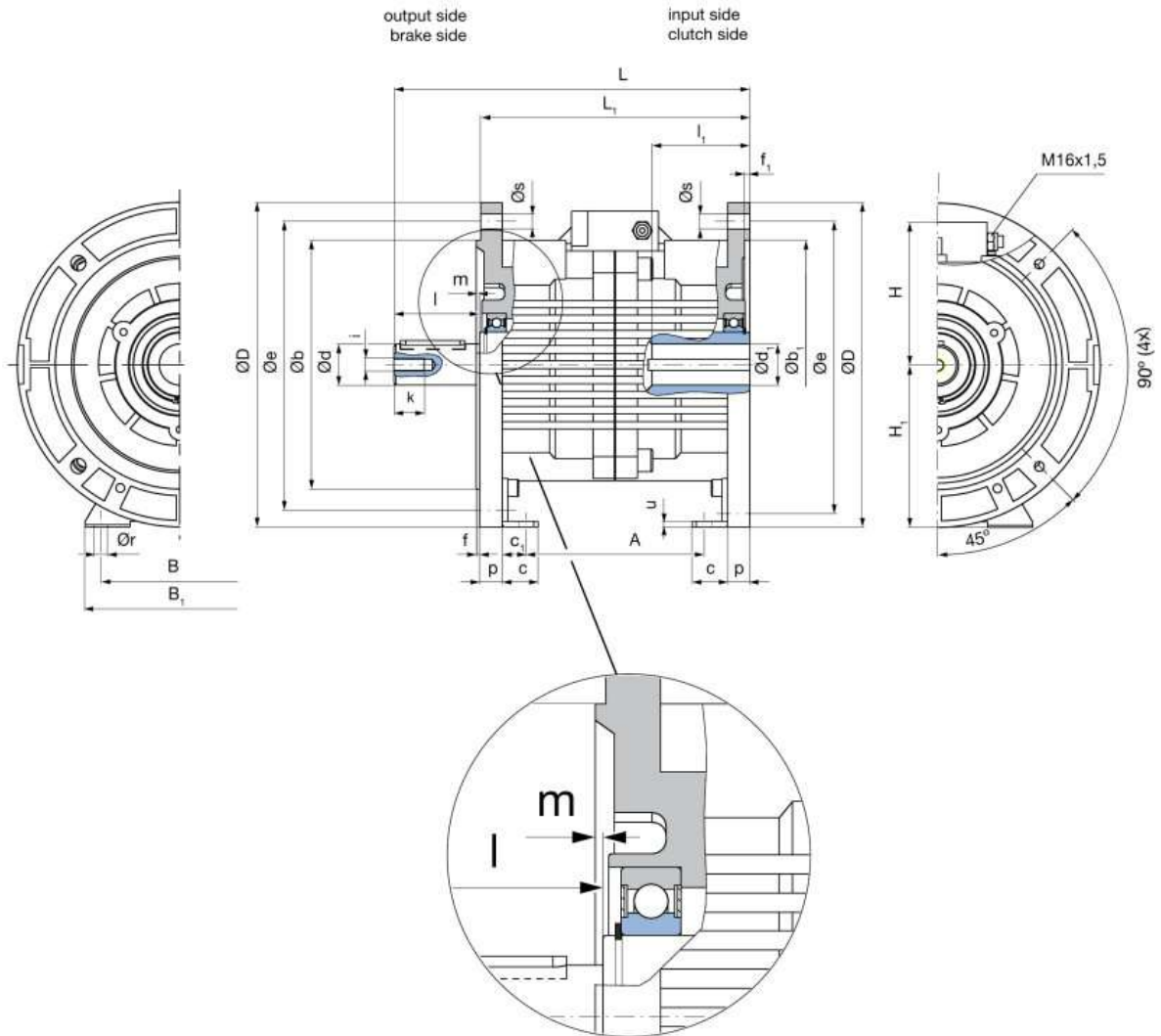

Order Number							
Brake side IEC-flange small 5 IEC-flange large 6		Clutch side IEC-flange small 5 IEC-flange large 6					
▼		▼					
_ / 6 7		_ . 0		_ . 0 / _ / W_ / B_		with control unit	
▲		▲		▲		▲	
Sizes 3 to 7	without feet	0	Coil voltage [VDC]	24	output shaft *	input hollow shaft bore *	see pages 56 - 58
	with feet	1		104	Ø d _{KB}	Ø d _{FB}	

ROBA®-takt clutch brake module

mayr®

Sizes 3 – 7

Type 67..0..0

Technical Data				Size				
				3	4	5	6	7
Nominal torque	Clutch	M_2	[Nm]	10	20	45	80	160
	Brake	M_2	[Nm]	8,5	17	45	80	160
Electrical power	Clutch	P_{20}	[W]	17	25	30	44	79
	Brake	P_{20}	[W]	13	23	30	45	70
Maximum speed		n_{max}	[rpm]	3600	3600	3600	3600	3600
Weight	Type 674.014.0	m	[kg]	3,9	6,8	9,9	15,3	27,7
Mass moment of inertia	Output Type 674.014.0	I	[10 ⁻⁴ kgm ²]	2,5	6,37	21,5	60,5	138

Standard voltage 24 VDC; 104 VDC.
Permitted voltage tolerances acc. IEC 38 +/-10 %.

Dimensions IEC [mm]	Size									
	3		4		5		6		7	
optionally with small or large IEC-flange	IEC-small	IEC-large	IEC-small	IEC-large	IEC-small	IEC-large	IEC-small	IEC-large	IEC-small	IEC-large
D	140	160	160	200	200	200	200	250	250	300
d_{k6}	11	14	14	19	19	24	24	28	28	38
d_1^{FB}	11	14	14	19	19	24	24	28	28	38
b_{j6}	95	110	110	130	130	130	130	180	180	230
$b_1^{+0,3}$	95	110	110	130	130	130	130	180	180	230
e	115	130	130	165	165	165	165	215	215	265
f	3	3,5	3,5	3,5	3,5	3,5	3,5	4	4	4
f_1	3,5	4	4	4	4	4	4	4,5	4,5	4,5
H_1 ¹⁾	70	80	80	100	100	100	100	125	125	150
i	M4	M5	M5	M6	M6	M8	M8	M10	M10	M12
k	10	12,5	12,5	16	16	19	19	22	22	28
L	163	170	189	199	219	229	253	263	308	328
l	23	30	30	40	40	50	50	60	60	80
l_1	25	32	32	42	42	55	55	65	65	90
m	3	3,5	3,5	3,5	3,5	3,5	3,5	4	4	4
s	9	9	9	11	11	11	11	14	14	14

1) The difference in height of feet depends on the flange diameter

Dimensions [mm]	Size				
	3	4	5	6	7
A	94	106	115	139	166
B	75	95	110	120	145
B_1	93	115	136	152	175
c	19	22	28	28	33
c_1	11	13,5	18	18	21

1) Please observe the difference in height of the feet input side and output side.

Dimensions [mm]	Size				
	3	4	5	6	7
H	86	94	106	121	142
L_1	140	159	179	203	248
p	12	13	14	14	20
r	6,6	9	11	11	14
u	3	3	4	4	5

We reserve the right to make dimensional and constructional alterations.

Installation

Clutch Brake Unit with flange:

The shafts, centring, screw-on pitch circles and diameters of the flanges are designed according to IEC-standard. Input and output sides can be fitted with the corresponding flanges of motor, gearbox or other units without problems, as shown in Fig. 1.

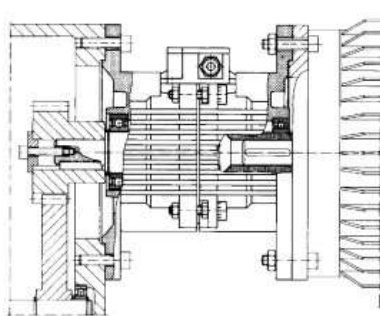

Fig. 1

Installation of the transmission elements:

The drive elements are mounted onto the respective shafts and secured axially via a press cover and a screw screwed into the threaded centre hole of the shaft, see Fig. 2.

For the combination motor shaft - ROBA®-takt hollow shaft, the motor shaft must be greased slightly to prevent frictional corrosion. Extensive force or hammer blows can damage the bearings. Radial loads acting on the shaft via the drive elements must not exceed the maximum allowable values (see heading „permissible shaft load“).

Should both radial and axial loads be present on the shaft, the permissible loads must be determined - please contact our engineers.

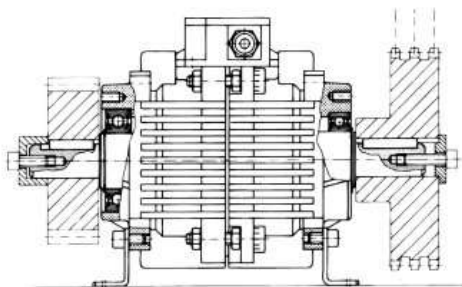

Fig. 2

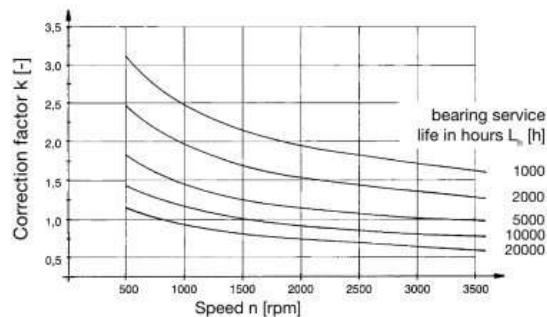

Diagram 1

Permitted shaft loads

The drive elements located on the shafts exert a radial load during operation which has to be absorbed by the bearings of the unit. The load is limited by the required life of the bearings and strength of the shaft (Table 1).

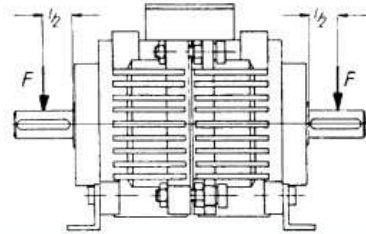

Fig. 3

ROBA®-takt max. permitted radial force F _{max} [N]	Size				
	3	4	5	6	7
Input shaft without IEC-flange	333	995	2150	2705	5355
Output shaft without IEC-flange	333	1105	2331	2950	6211
Output shaft small IEC-flange	-	-	-	-	-
Output shaft large IEC-flange	333	1105	2331	2950	6211

Table 1: Max. permitted radial force F_{max} limited due to the strength of the shaft, application of load midway along shaft.

The application of load is assumed to be midway along the shaft, determining the acceptable radial load. In case of additional axial loads, an extensive calculation is necessary (please contact the manufacturer).

The permitted radial forces stated in Table 2 refer to a speed of n = 1500 rpm and a bearing service life L_n = 10 000 hours.

ROBA®-takt Radial force F _n [N]	Size				
	3	4	5	6	7
Input shaft without IEC-flange	436	547	681	819	1149
Output shaft without IEC-flange	788	1052	1484	1685	2861
Output shaft small IEC-flange	840	1134	1586	1785	3115
Output shaft large IEC-flange	788	1052	1484	1685	2861

Table 2: Permitted radial force F_n with speed n = 1500 rpm, bearing service life L_n = 10 000 hours assuming load applied midway along shaft.

The permitted force F can be calculated with factor k for other speeds or bearing lifetimes. The factor k is determined from diagram 1.

F = k × F_n ≤ F_{max} [N]

F in N = Permitted radial force
 k = Correction factor (diagram 1)
 F_n in N = Permitted radial force at n = 1500 rpm and bearing service life L_n = 10 000 hours (Table 2)
 F_{max} in N = Max. permitted radial force, limited due to shaft strength (Table 1)

Technical Explanations

ROBA®-takt clutch brake module



Clutch brake modul size calculation

Formulas

Basis: $M_L = \text{constant}$
 $M_S = \text{constant}$

1. Drive torque

$$M_A = \frac{9550 \times P_A}{n} \quad [\text{Nm}]$$

2. Required torque

$$M_{\text{req.}} \geq K \times M_A \quad [\text{Nm}]$$

3. Pre-selection of the unit size acc. diagram 1 page 54

$$M_S \geq M_{\text{req.}} \quad [\text{Nm}]$$

4. Mass moment of inertia

$$I = I_{\text{own}} + I_{\text{add.}} \quad [\text{kgm}^2]$$

5. Acceleration time input side ($M_A \geq M_S$)

$$t_a = \frac{I \times n}{9,55 \times (M_S (+) M_L)} + t_1^{(1)} \quad [\text{sec}]$$

6. Braking time output side

$$t_v = \frac{I \times n}{9,55 \times (M_S (+) M_L)} + t_1^{(2)} \quad [\text{sec}]$$

7. Max. switching frequency per hour (dependent on time)

$$S_{h,\text{max}} = \frac{1}{(t_v + t_a) \times 1,2} \times 3600 \quad [\text{h}^{-1}]$$

8. Friction work per acceleration

$$Q_a = \frac{I \times n^2}{182,4} \times \frac{M_S}{M_S (+) M_L} \quad [\text{J}]$$

$$Q_a < Q_E \quad [\text{J}]$$

9. Friction work per delay

$$Q_v = \frac{I \times n^2}{182,4} \times \frac{M_S}{M_S (+) M_L} \quad [\text{J}]$$

$$Q_v < Q_E \quad [\text{J}]$$

10. Check the selected unit size

in diagram 2 (page 54 friction power diagram).
The point of intersection of friction work (switching work)/
cycling frequency must be below the friction power curve!
If it is above, the next size has to be selected and
re-calculated from point 3 on.

11. Number of switchings until wear limit

$$Z = \frac{Q_{\text{tot.}}}{* Q_a (Q_v) \times 2} \quad [-]$$

* Q_a/Q_v - put in higher value

Key:

P_A	[kW]	drive power	
M_A	[Nm]	drive torque	
$M_{\text{req.}}$	[Nm]	required torque	
M_L	[Nm]	load torque ($(+)$ / $(-)$ = drop load) In case of a load reduce the value in the bracket	
M_S	[Nm]	switchable torque (diagram 1, page 54)	
n	[rpm]	drive speed	
K		safety factor	≥ 2
I	[kgm ²]	mass moment of inertia	
I_{own}	[kgm ²]	own mass moment of inertia ("Technical data")	
$I_{\text{add.}}$	[kgm ²]	additional mass moment of inertia	
t_a	[sec]	acceleration time (input side)	
t_v	[sec]	braking time (output side)	
$t_1^{(1)}$	[sec]	switching time of the clutch	Table 3, page 55
$t_1^{(2)}$	[sec]	switching time of the brake	Table 3, page 55
$S_{h,\text{max}}$	[h ⁻¹]	max. switching frequency per hour (dependent on time)	
$Q_{\text{tot.}}$	[J]	total friction work (acc. to Table 4, page 55)	
Q_a	[J]	friction work per acceleration	
Q_E	[J]	perm. friction work with single switching	Table 4, page 55
Q_v	[J]	friction work per deceleration	Table 4, page 55
t_s	[s]	delay times	
Z		number of switchings until wear limit	

Calculation example

Data:

Input power $P_A = 0,75$ kW
 Input speed $n = 1400$ rpm
 Load torque output $M_L = 3,0$ Nm
 Additional mass moment of inertia $I_{add.} = 0,0042$ kgm²
 3000 cycles per hour

Drive torque

$$M_A = \frac{9550 \times P_A}{n} = \frac{9550 \times 0,75}{1400} = 5,1 \text{ [Nm]}$$

Required torque

$$M_{req.} = K \times M_A = 2 \times 5,1 = 10,2 \text{ [Nm]}$$

Determined unit size acc. diagram 1 = Size 4

$$M_S \geq M_{req.} = 11 \text{ [Nm]}$$

Mass moment of inertia

$$I = I_{own} + I_{add.} = 0,000637 + 0,0042 = 0,00484 \text{ [kgm}^2\text{]}$$

Acceleration time input side (lift load) ($M_A \geq M_S$)

$$t_a = \frac{I \times n}{9,55 \times (M_S (+) M_L)} + *t_{1.1} \text{ (clutch)}$$

$$t_a = \frac{0,00484 \times 1400}{9,55 \times (11 - 3)} + 0,065 = 0,153 \text{ [sec]}$$

Braking time output side (drop load)

$$t_v = \frac{I \times n}{9,55 \times (M_S (-) M_L)} + *t_{1.2} \text{ (brake)}$$

$$t_v = \frac{0,00484 \times 1400}{9,55 \times (11 - 3)} + 0,040 = 0,129 \text{ [sec]}$$

* switching times $t_{1.1}$ and $t_{1.2}$ from Table 3, page 55 = without overexcitation

Max. switching frequency per hour

$$S_{n \max} = \frac{1}{(t_v + t_a) \times 1,2} \times 3600$$

$$S_{n \max} = \frac{1}{(0,129 + 0,153) \times 1,2} \times 3600 = 10,638 \text{ [h}^{-1}\text{]}$$

Friction work per acceleration

$$Q_a = \frac{I \times n^2}{182,4} \times \frac{M_S}{M_S - M_L}$$

$$Q_a = \frac{0,00484 \times 1400^2}{182,4} \times \frac{11}{11 - 3} = 71,5 \text{ [J]} \leq Q_e$$

Friction work per deceleration

$$Q_v = \frac{I \times n^2}{182,4} \times \frac{M_S}{M_S + M_L}$$

$$Q_v = \frac{0,00484 \times 1400^2}{182,4} \times \frac{11}{11 + 3} = 40,9 \text{ [J]} \leq Q_e$$

Check the selected unit size in the friction power diagram (determine point of intersection Q_a or Q_v to S_n).
 (The point of intersection determined in diagram 2 must be located in or under the characteristic curve of the selected unit).

Number of switchings until wear limit

$$Z = \frac{Q_{tot}}{Q_a \times 2} = \frac{44 \times 10^7}{71,5 \times 2} = 3,08 \times 10^6 \text{ switchings}$$

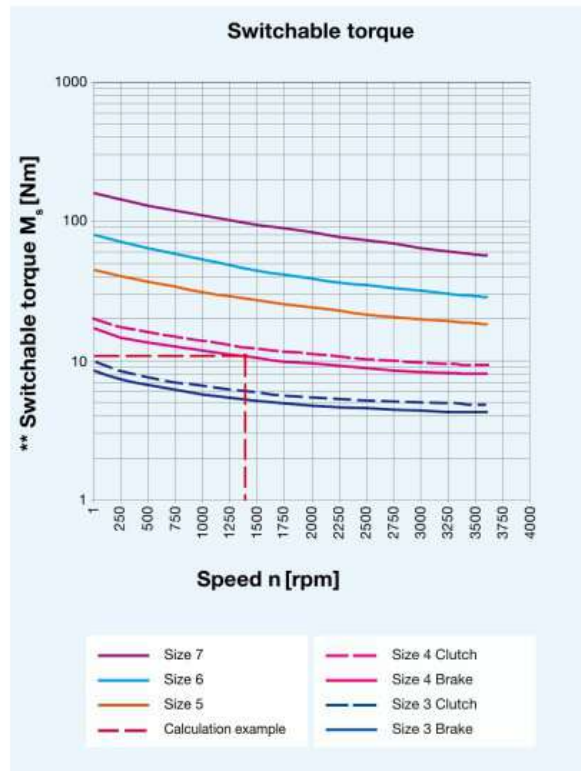

Diagram 1

** Friction surfaces have been run

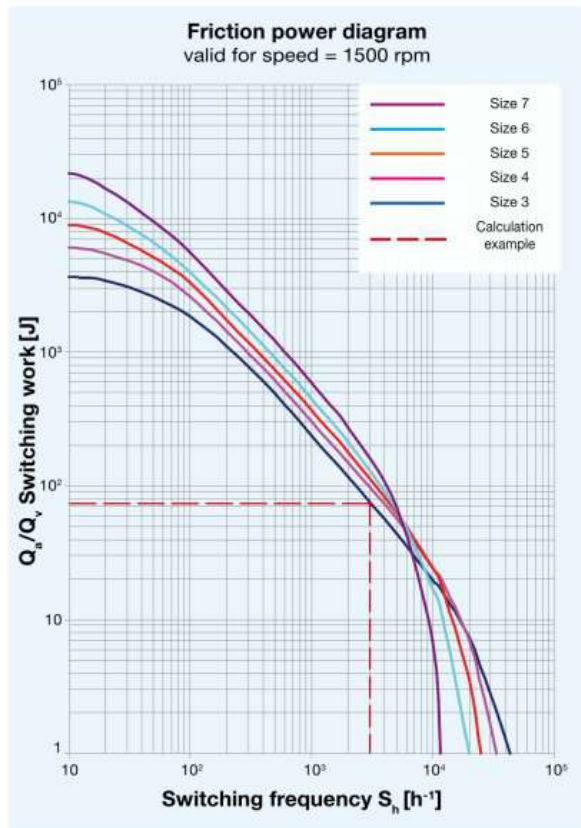

Diagram 2

Technical Explanations

ROBA®-takt clutch brake module



Switching Times

The switching times stated in Table 3 have been determined by comprehensive series of tests. They are valid for switching DC-side with nominal air gap and warm coil. Deviations depend on the respective installation situation, ambient temperatures, release path and the type of rectification with which the corresponding clutch is operated.

Switching times				Size				
				3	4	5	6	7
Without overexcitation	t_{11}	Clutch	[sec]	0,010	0,015	0,020	0,030	0,045
	t_1	Clutch	[sec]	0,045	0,065	0,080	0,150	0,200
	t_{11}	Brake	[sec]	0,006	0,008	0,010	0,015	0,025
	t_1	Brake	[sec]	0,035	0,040	0,055	0,100	0,150
	t_2	Clutch	[sec]	0,012	0,020	0,045	0,060	0,090
	t_2	Brake	[sec]	0,010	0,018	0,030	0,060	0,090
With overexcitation (only switch-on time)	t_{11}	Clutch	[sec]	0,003	0,005	0,007	0,010	0,015
	t_1	Clutch	[sec]	0,025	0,035	0,040	0,075	0,100
	t_{11}	Brake	[sec]	0,002	0,003	0,004	0,006	0,008
	t_1	Brake	[sec]	0,020	0,022	0,030	0,050	0,075
Recommended duration of overexcitation			[sec]	0,010 ¹⁾	0,010 ¹⁾	0,010	0,015	0,020
Minimal necessary slope separation	with overexcitation		[sec]	0,020	0,025	0,030	0,080	0,120
	without overexcitation		[sec]	0	0	0,015	0,050	0,080

Height of the overexcitation = approx. 10 x nominal voltage (current limited)

Table 3

1) In case of operation with overexcitation and high switching frequency (80-100 % of the diagram value), the recommended period of the overexcitation acc. Table 3 must not be exceeded.

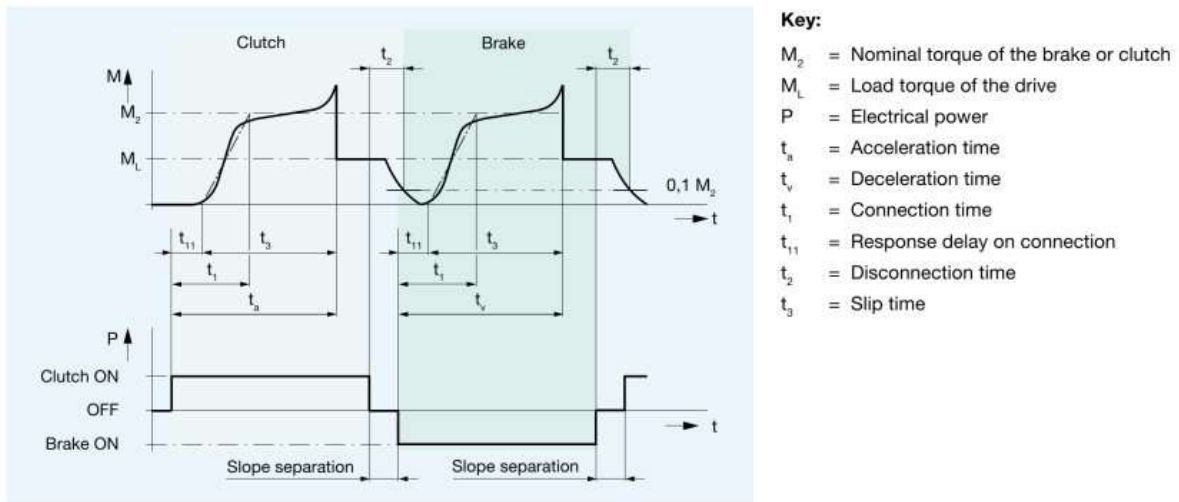

Diagram 3: Torque-time

Friction work		Size				
		3	4	5	6	7
Permitted friction work for single switching	Q_E [10^3 J]	3,8	6,2	9	15	25
Total friction work	$Q_{tot.}$ [10^7 J]	22,5	44	87	171	340

Table 4

Please Observe!

Wear values can only be **recommended values** due to operating parameters, such as sliding speed, pressing or temperature.

Application

This unit is used to start, stop and to position by switching and controlling the *mayr*® ROBA®-takt clutch brake modules.

Function

The ROBA®-takt control unit operates according to the principle of a clocked switching controller with a frequency of 18 kHz. Its coil is energised by actuating the sensor for clutch and brake. A temperature monitor protects the unit from overheating. Should the temperature exceed $>80\text{ }^{\circ}\text{C}$, the coil voltage is switched off. The LED "excess temperature unit" lights up red. A slope separation avoids simultaneous occurrence of clutch and brake torques. On overexcitation, the coil attraction time is reduced, allowing exact switching and positioning.



Electrical Connection

1	Coil connection for clutch	Ku1 / Ku2
2	Coil connection for brake	Br1 / Br2
3	Sensor connection for clutch	+12 V / Ku / Gnd1
4	Sensor connection for brake	+12 V / Br / Gnd2
5	Connection input voltage	PE, L1, N
6	Temperature monitoring	Option 1 (bare)
7	Signalling relay	Option 2 (bare)

Technical Data

Input voltage	230 VAC $\pm 10\%$, 50-60 Hz
Power input	max. 4 Ampere /100 % duty cycle
No-load supply power	< 7 Watt
Coil _{Norm} -Voltage	24 VDC
Coil _{Norm} -power	maximal 96 Watt
Coil _{Norm} -current	Manufacturer-side setting to <i>mayr</i> ® ROBA®-takt-size
Coil overexcitation	maximal 325 VDC
Overexcitation time	current limitation is adapted to the respective coil size 2-50 ms (-30% to $+60\%$), externally adjustable (only applicable with coding "overexcitation ON")
Slope separation	2-150 ms (-25% to $+30\%$), externally adjustable
Protection	IP20
Ambient temperature	$0\text{ }^{\circ}\text{C}$ to $+50\text{ }^{\circ}\text{C}$
Storage temperature	$-20\text{ }^{\circ}\text{C}$ to $+70\text{ }^{\circ}\text{C}$
Clamping conductor cross section	$2,5\text{ mm}^2$
Weight	$1,5\text{ kg}$ / $3,31\text{ lb}$
Protection fuse Input-side: G-microfuse	F1/F2, (M) 4 A, 5x20mm
Protection fuse Coil-side: G-microfuse	F3, the current is adapted to the ROBA®-takt sizes. Always use the same replacement fuses
Overvoltage category	two; one for connection to PELV/SELV PELV/SELV (control wires)
Overvoltage protection	For installation in overvoltage category III, a suitable overvoltage protection unit is required between the incoming voltage and the ROBA®-takt control unit.

Dimensions (mm)

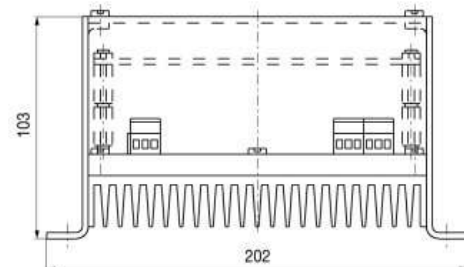
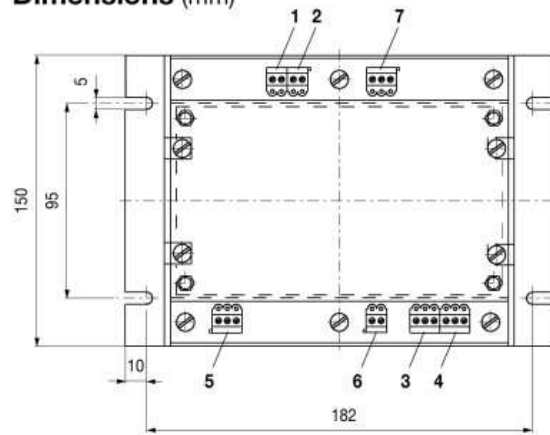

Order Number

— / 0 1 4 . 0 0 0 . 2



Sizes 3 - 7
ROBA®-takt control unit

Control unit temperature monitoring

A fitted temperature switch prevents the control unit from overheating.

Functional Sequence

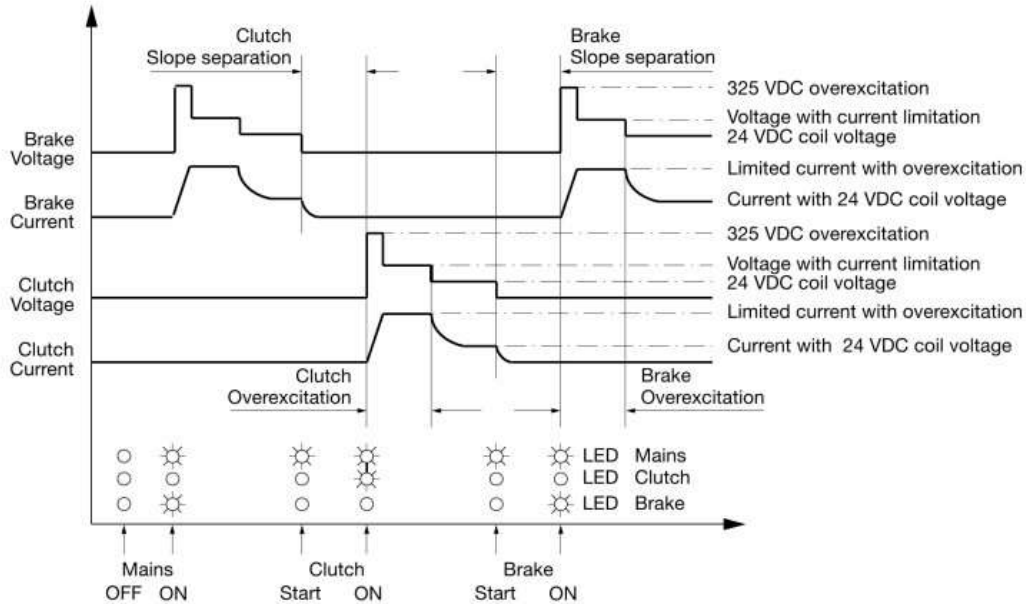

Connection Example		Connection example 1-sensor operation		Connection example 2-sensor operation	
Control elements / control function Control sensor for start and stop		12V Ku Gnd 1 12V Br Gnd 2		12V Ku Gnd 1 12V Br Gnd 2	
Brake = (Br) Clutch = (Ku)		Function (condition-controlled)		Function (slope-controlled)	
Application		Close contact	Clutch ON	Close contact clutch or	Clutch ON
Contact potential-free (NO-Contact)		Open contact	Brake ON	Close contact brake	Brake ON
SPS - Control (10 - 30 VDC)		+ 24 VDC signal	Clutch ON	+ 24 VDC signal to clutch or	Clutch ON
		0 VDC signal	Brake ON	+ 24 VDC signal to brake	Brake ON
External voltage (10 - 30 VDC)		+10 - 30 VDC signal	Clutch ON	+10 - 30 VDC signal to clutch or	Clutch ON
		0 VDC signal	Brake ON	+10 - 30 VDC signal to brake	Brake ON
NAMUR Proximity switch (10 - 30 VDC)		Sensor undamped	Clutch ON	Sensor clutch undamped or	Clutch ON
		Sensor damped	Brake ON	Sensor brake undamped	Brake ON
PNP - NC contact Proximity switch (10 - 30 VDC)		Sensor undamped	Clutch ON	Geber Kupplung undamped or	Clutch ON
		Sensor damped	Brake ON	Sensor brake undamped	Brake ON



Application

This device is used to start and stop *mayr*® ROBA®-takt clutch brake modules.

It can be used for alternating 24 VDC coil switching, if a 24 VDC power supply is available.

Function

1-sensor operation:
 activated clutch is energised
 deactivated brake is energised

The respective control of the clutch or brake is indicated via LED.
 The ROBA®-takt circuit module has no over excitation function.

The brake has priority: The brake is energised independently of the sensor position when the 24 VDC power supply is switched on. The coil is energised with the 24 VDC power supply.



Slope separation: To avoid simultaneous clutch and braking torques, a slope separation of 0 - 100 ms between clutch and brake can be set, which acts according to the respective rise time and drop-out time of the coils (see switching time table). This adjustment is carried out via the potentiometers Ku = clutch (P2) and Br = brake (P1). The factory default setting is 0 ms.

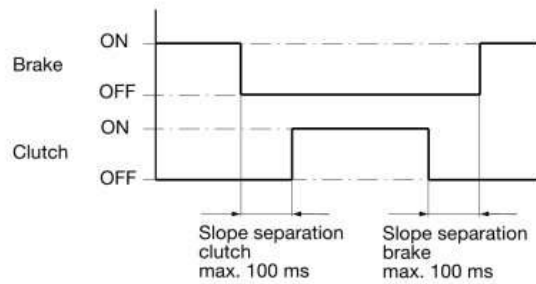

Electrical Connection (Terminals)

1	Input voltage	24 VDC
2	Input voltage	GND
3 + 4	Brake	
5 + 6	Clutch	
7	Control voltage for switches or sensors	12 VDC
8 + 9	Control inputs	

Technical Data

Input voltage 24 VDC **SELV/PELV** ripple content ≤ 5%

Recommended fuse T 4A

Output voltage 24 VDC

Output power maximal 79 W

Slope separation 0 - 100 ms
 (factory default setting is 0 ms)

Ambient temperature 0 °C to +70 °C

Storage temperature -20 °C to +85 °C

Conductor cross section 0,14 - 1,5 mm² / AWG 26 - 14

Protection IP00

Design Printed board with screw-on attachment part or a mounting frame for 35 mm standard mounting rails

Maximal cycle frequencies		45 °C	70 °C
up to 1 A / sizes 3 + 4	cycles / min	600	600
approx. 2 A / sizes 5 + 6	cycles / min	240	180
approx. 3 A / size 7	cycles / min	120	75

Please Observe!

Higher cycle frequencies will lead to ROBA®-takt circuit module overload and failure.

Dimensions (mm)

Dimensions with mounting frame

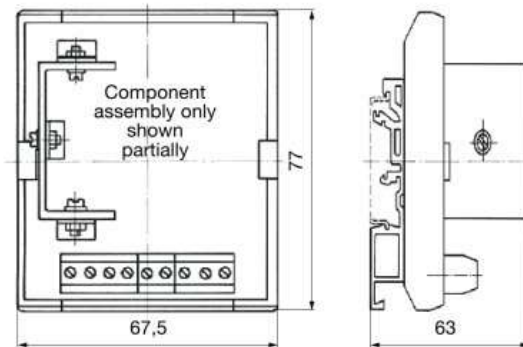

Order Number

__ / 0 0 4 . 0 0 0 . __



Size	only printed board without frame	0
1	printed board with mounting frame	1

Headquarters

Chr. Mayr GmbH + Co. KG
Eichenstrasse 1, D-87665 Mauerstetten
Tel.: 0 83 41/8 04-0, Fax: 0 83 41/80 44 21
www.mayr.de, E-Mail: info@mayr.de



mayr[®]

Service Germany

Baden-Württemberg

Esslinger Straße 7
 70771 Leinfelden-Echterdingen
 Tel.: 07 11/45 96 01 0
 Fax: 07 11/45 96 01 10

Bavaria

Eichenstrasse 1
 87665 Mauerstetten
 Tel.: 0 83 41/80 41 04
 Fax: 0 83 41/80 44 23

Chemnitz

Bornaer Straße 205
 09114 Chemnitz
 Tel.: 03 71/4 74 18 96
 Fax: 03 71/4 74 18 95

Franken

Unterer Markt 9
 91217 Hersbruck
 Tel.: 0 91 51/81 48 64
 Fax: 0 91 51/81 62 45

Hagen

Im Langenstück 6
 58093 Hagen
 Tel.: 0 23 31/78 03 0
 Fax: 0 23 31/78 03 25

Kamen

Lünener Strasse 211
 59174 Kamen
 Tel.: 0 23 07/23 63 85
 Fax: 0 23 07/24 26 74

North

Schiefer Brink 8
 32699 Extertal
 Tel.: 0 57 54/9 20 77
 Fax: 0 57 54/9 20 78

Rhine-Main

Hans-Böckler-Straße 6
 64823 Groß-Umstadt
 Tel.: 0 60 78/7 82 53 37
 Fax: 0 60 78/9 30 08 00

Branch office

China

Mayr Zhangjiagang
 Power Transmission Co., Ltd.
 Changxing Road No. 16,
 215600 Zhangjiagang
 Tel.: 05 12/58 91-75 65
 Fax: 05 12/58 91-75 66
 info@mayr-ptc.cn

Great Britain

Mayr Transmissions Ltd.
 Valley Road, Business Park
 Keighley, BD21 4LZ
 West Yorkshire
 Tel.: 0 15 35/66 39 00
 Fax: 0 15 35/66 32 61
 sales@mayr.co.uk

France

Mayr France S.A.
 Z.A.L. du Minopole
 BP 16
 62160 Bully-Les-Mines
 Tel.: 03.21.72.91.91
 Fax: 03.21.29.71.77
 contact@mayr.fr

Italy

Mayr Italia S.r.l.
 Viale Veneto, 3
 35020 Saonara (PD)
 Tel.: 0 49/8 79 10 20
 Fax: 0 49/8 79 10 22
 info@mayr-italia.it

Singapore

Mayr Transmission (S) PTE Ltd.
 No. 8 Boon Lay Way Unit 03-06,
 TradeHub 21
 Singapore 609964
 Tel.: 00 65/65 60 12 30
 Fax: 00 65/65 60 10 00
 info@mayr.com.sg

Switzerland

Mayr Kupplungen AG
 Tobeläckerstrasse 11
 8212 Neuhausen am Rheinfall
 Tel.: 0 52/6 74 08 70
 Fax: 0 52/6 74 08 75
 info@mayr.ch

USA

Mayr Corporation
 4 North Street
 Waldwick
 NJ 07463
 Tel.: 2 01/4 45-72 10
 Fax: 2 01/4 45-80 19
 info@mayrcorp.com

Representatives

Australia

Transmission Australia Pty. Ltd.
 22 Corporate Ave,
 3178 Rowville, Victoria
 Australien
 Tel.: 0 39/7 55 44 44
 Fax: 0 39/7 55 44 11
 info@transaus.com.au

China

Mayr Power Transmission Co., Ltd.
 Shanghai Representative Office
 Room 2206, No. 888 Yishan Road
 200233 Shanghai, VR China
 Tel.: 0 21/64 32 01 60
 Fax: 0 21/64 57 56 21
 Trump.feng@mayr.de

India

National Engineering
 Company (NENCO)
 J-225, M.I.D.C.
 Bhosari Pune 411026
 Tel.: 0 20/27 13 00 29
 Fax: 0 20/27 13 02 29
 nenco@nenco.org

Japan

MATSUI Corporation
 2-4-7 Azabudai
 Minato-ku
 Tokyo 106-8641
 Tel.: 03/35 86-41 41
 Fax: 03/32 24 24 10
 k.goto@matsui-corp.co.jp

South Africa

Torque Transfer
 Private Bag 9
 Elandsfontein 1406
 Tel.: 0 11/8 99 00 00
 Fax: 0 11/8 99 65 74
 torque@bearings.co.za

South Korea

Mayr Korea Co. Ltd.
 Room No.1002, 10th floor,
 Nex Zone, SK TECHNOPARK,
 77-1, SungSan-Dong,
 SungSan-Gu, Changwon, Korea
 Tel.: 0 55/2 62-40 24
 Fax: 0 55/2 62-40 25
 info@mayrkorea.com

Taiwan

German Tech Auto Co., Ltd.
 No. 28, Fenggong Zhong Road,
 Shengang Dist.,
 Taichung City 429, Taiwan R.O.C.
 Tel.: 04/25 15 05 66
 Fax: 04/25 15 24 13
 abby@zfgta.com.tw

Machine tools

Applications in China
 Dynamic Power Transmission Co., Ltd.
 Block 5th, No. 1699, Songze Road,
 Xujing Industrial Zone
 201702 Shanghai, China
 Tel.: 021/59883978
 Fax: 021/59883979
 dtcshanghai@online.sh.cn

More representatives:

Austria, Benelux States, Brazil, Canada, Czech Republic, Denmark, Finland, Greece, Hongkong, Hungary, Indonesia, Israel, Malaysia, New Zealand, Norway, Philippines, Poland, Romania, Russia, Slovakia, Slovenia, Spain, Sweden, Thailand, Turkey

You can find the complete address for the representative responsible for your area under www.mayr.com in the internet.

mayr[®]
 your reliable partner

Product Summary

Safety Clutches/Overload Clutches

- ❑ **EAS®-Compact®/EAS®-NC**
Positive locking and completely backlash-free torque limiting clutches
- ❑ **EAS®-smartic®**
Cost-effective torque limiting clutches, quick installation
- ❑ **EAS®-element clutch/EAS®-elements**
Load-disconnecting protection against high torques
- ❑ **EAS®-axial**
Exact limitation of tensile and compressive forces
- ❑ **EAS®-Sp/EAS®-Sm/EAS®-Zr**
Load-disconnecting torque limiting clutches with switching function
- ❑ **ROBA®-slip hub**
Load-holding, frictionally locked torque limiting clutches
- ❑ **ROBA®-contitorque**
Magnetic continuous slip clutches



Shaft Couplings

- ❑ **smartflex®**
Perfect precision couplings for servo and stepping motors
- ❑ **ROBA®-ES**
Backlash-free and damping for vibration-sensitive drives
- ❑ **ROBA®-DS/ROBA®-D**
Backlash-free, torsionally rigid all-steel couplings
- ❑ **EAS®-control-DS**
Cost-effective torque-measuring couplings



Electromagnetic Brakes/Clutches

- ❑ **ROBA-stop® standard**
Multifunctional all-round safety brakes
- ❑ **ROBA-stop®-M motor brakes**
Robust, cost-effective motor brakes
- ❑ **ROBA-stop®-S**
Water-proof, robust monoblock brakes
- ❑ **ROBA-stop®-Z/ROBA-stop®-silenzio®**
Doubly safe elevator brakes
- ❑ **ROBA®-diskstop®**
Compact, very quiet disk brakes
- ❑ **ROBA®-topstop®**
Brake systems for gravity loaded axes
- ❑ **ROBA®-linearstop**
Backlash-free brake systems for linear motor axes
- ❑ **ROBATIC®/ROBA®-quick/ROBA®-takt**
Electromagnetic clutches and brakes, clutch brake units



DC Drives

- ❑ **tendo®-PM**
Permanent magnet-excited DC motors
- ❑ **tendo®-SC**
1 quadrant and 4 quadrant transistor controllers



15/05/2012 GF/SC