



your reliable partner



ROBA-stop[®]-silenzio[®]

K.896.V16.EN

www.mayr.com



Expert know-how in development and design

As the technological leader, *mayr*[®] power transmission focuses on continuous further development. Today, highly qualified engineers and technicians work on tomorrow's innovations using the most up-to-date tools. The years of experience and countless tests at the Development and Testing Department at the Mauerstetten Headquarters form the basis of conscientious lifetime dimensioning.

The values upheld by our traditional, family-run company also include long-term stability, independence as well as a good reputation and satisfied customers.

Therefore, we place emphasis on:

- Tested product quality,
- Optimum customer service,
- Comprehensive know-how,
- Global presence,
- Successful innovations and
- Effective cost management

Tested quality and reliability

mayr[®] brakes and couplings are subject to meticulous quality inspections. These include quality assurance measures during the construction process as well as a comprehensive final inspection. Only the best, tested quality leaves our factory. All products are rigorously tested on calibrated test stands, and adjusted precisely to the requested values. An electronic database in which the measurement values are archived together with the associated serial numbers guarantees 100 % traceability. On request, we confirm the product characteristics with a test protocol.

The certification of our quality management according to DIN EN ISO 9001:2008 confirms the quality-consciousness of our colleagues at every level of the company.

Specialists for power transmission for more than a century

mayr® power transmission is one of the most traditional and yet most innovative companies in the field of power transmission. From modest beginnings in the year 1897, the family enterprise has developed into world market leader. Worldwide, the company employs more than 1000 people.

Unsurpassed - our standard range

mayr® power transmission offers an extensive variety of torque limiters, safety brakes, backlash-free shaft misalignment compensation couplings and high-quality DC drives. Numerous renowned machine manufacturers trust in solutions by mayr® power transmission.

Available worldwide

With eight subsidiaries in Germany, sales offices in the USA, France, Great Britain, Italy, Singapore and Switzerland as well as 36 additional country representatives, mayr® is available in all important industrial areas, guaranteeing optimum customer service around the globe.

Never compromise on safety

We make no compromises where safety is concerned. Only top products of a perfect quality guarantee that no people are injured or machines damaged in case of malfunctions, collisions and other hazardous situations. The safety of your employees and machines is our motivation to always provide the best and most reliable clutches, couplings or brakes.

mayr® power transmission holds numerous ground-breaking patents, and is the global market or technological leader for

- application-optimised **safety brakes**, for example for passenger elevators, stage technology and gravity loaded axes
- **torque limiters** to protect against expensive overload damage and production losses and
- backlash-free **servo couplings**.

Strongly positioned

mayr® sets standards in power transmission with economically viable solutions. For maximum competitiveness of your machines and systems, we always aim for the best possible cost efficiency, starting during the development of your clutch/coupling or brake right up to delivery of the finished and inspected product. For cost-efficient production, our factories in Poland and China represent the perfect supplement to the headquarters in Germany.



mayr®-headquarters in Mauerstetten



Subsidiary with production department — mayr®-China



Subsidiary with production department — mayr®-Poland

ROBA-stop®-silenzio®

**Reliable dual circuit brake
in accordance with DGUV
Rule 115-002 (previously
BGV C1), DIN 56950-1,
EN 81-A3 and other
international standards**

Characteristics

- **Dual circuit brake as redundant brake system with a very short construction length**
- **Microswitch or proximity switch can be mounted for release monitoring**
- **Simplest possible installation**
- **No air gap adjustment necessary**
- **Continuously low noise levels for several hundred thousand switchings**
- **From size 200 on, the brake types with release monitoring are approved as protection against excessive upwards speeds and are also compliant with EN 81-1:1998 + A3:2009.**

The quietest safety brake

Due to a newly developed noise damping unit, the ROBA-stop®-silenzio® is the quietest safety brake on the market, even in its standard version (pages 6 to 9). In new condition, the noise level is < 50 dB(A) (sound pressure level measurement). This value lies well below the noise level of the mounted drive elements such as e.g. motor and gearbox. Further noise reduction is possible. We can accord with your request as far as noise levels are concerned, and guarantee our performance with a legally binding inspection protocol.

High operational safety

The ROBA-stop®-silenzio® is available as a single circuit brake or as a dual circuit brake. On the dual circuit brake, two independently operating brake bodies ensure high operational safety. Certain variants of this brake type series fulfill the requirements acc. DGUV Rule 115-002 (previously BGV C1), DIN 56950-1, EN 81-A3 and can be designed according to the requirements stated in ASME A17.

Simple installation

The compact design as well as the single-part toothed hub ensures simple handling and installation. The working air gap is pre-set and needs no re-adjustment. This means that malfunctions due to operating and adjusting mistakes can be ruled out.



EN 81-A3
-conform

Safe choice due to large type and size variety

12 construction sizes in different designs fulfil the demands for elevator and stage drives with a braking torque range of 2 x 3 Nm to 2 x 2150 Nm and therefore cover all required operation areas.

If the power is switched off or in case of power failure or EMERGENCY STOP, the brakes ensure reliable and secure holding in any position; therefore, the brakes are intended mostly for static application as holding brakes.

Optimised construction space

Due to new construction and removal of the complicated intermediate flange plate, we have been able to create a unique short construction length.

Duty cycle

The ROBA-stop®-silenzio® safety brakes are optimised for a relative duty cycle of 60 %. For higher duty cycle, please contact the manufacturers. A duty cycle > 60% can lead to higher temperatures, which may influence the noise and switching behaviour of the brake.

Brake monitoring for maximum safety

The ROBA-stop®-silenzio® safety brakes are configurable for comprehensive brake monitoring. They can guarantee maximum operational and functional safety due to the permanent monitoring of the brake condition and the optimisation of the friction system:

- safe brake control
- conditioning of the friction linings
- refreshing of the friction linings
- fail-safe release monitoring for checking the switching condition of the brake
- wear inspection of the friction linings
- monitoring and evaluation of the friction system temperature
- static and dynamic braking torque tests

ROBA-stop®-silenzio®

Page 6 ▷

Sizes 4 to 1800

Braking torques

2 x 3 to 2 x 2150 Nm
 (Dual circuit brake)

3 to 2150 Nm
 (Single circuit brake)

Permitted shaft diameter

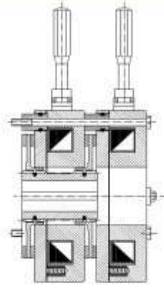
8 to 95

Type 896.0 __.3_
Dual circuit brake

 Redundant brake system
 with two independently
 working brake bodies

Type 896.1 __.3_
Single circuit brake

 Compact brake with an extremely
 short construction length

ROBA-stop®-silenzio® with double rotor design

Page 10 ▷

Sizes 300 to 1800

Braking torques

450 to 4300 Nm

Permitted shaft diameter

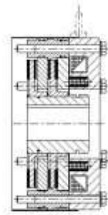
44 to 95

Type 896.2 __.3_
Double rotor design

 Single circuit brake with two rotors
 (4 friction surfaces) with
 doubled braking torque

In addition to the standard brakes, mayr® power transmission provides a multitude of further designs,
 which cannot be described in detail in this catalogue.
 For further options, please see page 15.

Short Description Installation

Page 12 ▷

Brake Dimensioning, Friction-Power Diagrams

Page 13 ▷

Further Options

Page 15 ▷

Switching Times

Page 16 ▷

Electrical Connection

Page 17 ▷

Contactless Release Monitoring

Page 19 ▷

Electrical Accessories: DC Voltage Modules / Brake Control Module

Page 20 ▷

Guidelines

Page 26 ▷



On request ROBA-stop®-
 silenzio® brakes can also be
 delivered with UL approval.

ROBA-stop®-silenzio® Type 896.0₁...3 – Sizes 4 to 100

Noises < 50 dB(A) (Sound pressure level measurement) at nominal braking torque

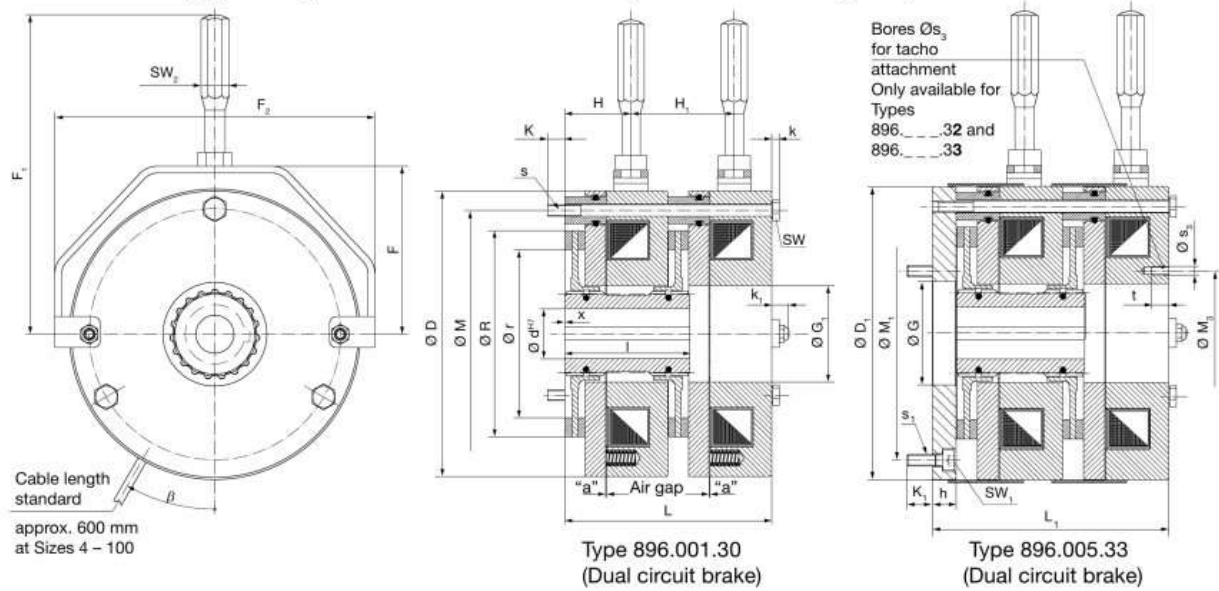

Technical Data			Size					
			4	8	16	32	64	100
Nominal braking torque ¹⁾	Type 896.00...3	M _N [Nm]	2 x 4	2 x 8	2 x 16	2 x 32	2 x 64	2 x 100
	Type 896.10...3	M _N [Nm]	4	8	16	32	64	100
Electrical power	Type 896.00...3	P ₂₀ [W]	2 x 23	2 x 31	2 x 33	2 x 45	2 x 55	2 x 63
	Type 896.10...3	P ₂₀ [W]	23	31	33	45	55	63
Maximum speed		n _{max} [rpm]	4500	3500	2900	2500	2300	2000
Weight (pilot bored)	Type 896.000.3		2 x 1.4	2 x 2.2	2 x 3.2	2 x 5.1	2 x 7.3	2 x 10.3
Nominal air gap (tolerance ± 0.07)		a [mm]	0.45	0.5	0.5	0.5	0.5	0.5

¹⁾ Braking torque tolerance: + 0 % / + 60 %. For other braking torque adjustments: see Table below.

Braking Torque Adjustment [Nm]						
	Size					
	4	8	16	32	64	100
Dual circuit brake Type 896.0...3						
100 %	2 x 4	2 x 8	2 x 16	2 x 32	2 x 64	2 x 100
120 %	2 x 5	2 x 10	2 x 19	2 x 40	2 x 77	2 x 120
75 %	2 x 3	2 x 6	2 x 12	2 x 26	2 x 43	2 x 80
Single circuit brake Type 896.1...3						
100 %	4	8	16	32	64	100
120 %	5	10	19	40	77	120
75 %	3	6	12	26	43	80

Bores [mm]								
	Size							
	4	8	16	32	64	100		
Dual circuit brake Type 896.0...3								
Braking torque adjustment	100 %	d _{min}	8	9	14	18	18	
		d _{max}	15 ²⁾	20 ³⁾	24 ⁴⁾	30	35 ⁵⁾	46 ⁶⁾
	120 %	d _{min}	8	9	14	18	18	20
		d _{max}	15 ²⁾	20 ³⁾	24 ⁴⁾	30	35 ⁵⁾	46 ⁶⁾
	75 %	d _{min}	8	9	14	18	18	18
		d _{max}	15 ²⁾	20 ³⁾	24 ⁴⁾	30	35 ⁵⁾	46 ⁶⁾
Single circuit brake Type 896.1...3								
Braking torque adjustment	100 %	d _{min}	8	9	14	18	22	
		d _{max}	15 ²⁾	20 ³⁾	24 ⁴⁾	30	35 ⁵⁾	46 ⁶⁾
	120 %	d _{min}	8	9	14	18	22	24
		d _{max}	15 ²⁾	20 ³⁾	24 ⁴⁾	30	35 ⁵⁾	46 ⁶⁾
	75 %	d _{min}	8	9	14	18	22	24
		d _{max}	15 ²⁾	20 ³⁾	24 ⁴⁾	30	35 ⁵⁾	46 ⁶⁾

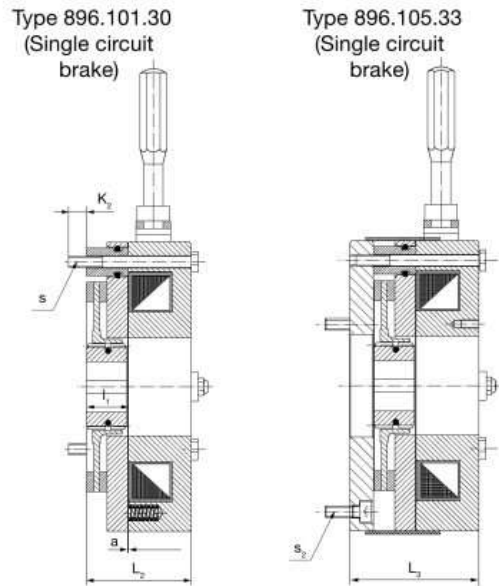

- 2) Over Ø 13 keyway acc. DIN 6885/3
- 3) Over Ø 18 keyway acc. DIN 6885/3
- 4) Over Ø 22 keyway acc. DIN 6885/3
- 5) Over Ø 32 keyway acc. DIN 6885/3
- 6) Over Ø 44 keyway acc. DIN 6885/3

Type 896.0
1-3 - Sizes 4 to 100

We reserve the right to make dimensional and constructional alterations.

Dimensions	Size					
	4	8	16	32	64	100
Ø D	88	108	130	153	168	195
Ø D ₁	88	108	130	153	168	195
F	50.5	64	79	88.5	97	111
F ₁	112.5	123	166.5	175.6	235	249
F ₂	105	128	158	175	190	222
Ø G	26	45	45	52	60	77
G ₁	29	36	45	52	60	77
H	29	27	33	37	42	36
H ₁	43	45.5	49	55	64	67
h	9	10	13	12	15	17
K	8.3	9	11.6	9.6	11.4	14.6
K ₁	8	7.5	10.8	10.8	14	14
K ₂	6.7	9.5	10.8	9	9.9	11.5
k	2.8	3.5	4	4	5.3	5.3
k ₁	7.2	10.5	10.1	10.2	14.5	19.6
L	87	91	99	109	127	134
L ₁	96	101	112	121	142	151
L ₂	43.5	45.5	49	54.5	63.5	67
L ₃	52.5	55.5	62	66.5	78.5	84
I	50	52	58	67	75	79
l ₁	18	20	20	25	30	30
Ø M	72	90	112	132	145	170
Ø M ₁	72	90	112	132	145	170
Ø M ₂	35	41	52	61	75	88
Ø R	60	75	93	110.5	124	139
Ø r	50	65	77	90	94	100
s	3 x M4	3 x M5	3 x M6	3 x M6	3 x M8	3 x M8
s ₁	3 x M4	3 x M5	3 x M6	3 x M6	3 x M8	6 x M8
s ₂	3 x M4	3 x M5	3 x M6	3 x M6	3 x M8	3 x M8
s ₃	3 x M4	3 x M4	3 x M4	3 x M5	3 x M5	3 x M5
SW	7	8	10	10	13	13
SW ₁	3	4	5	5	6	6
SW ₂	Ø 20 ⁷⁾	11	14	14	17	17
t	10	10	10	10	10	10
x ⁸⁾	± 0.5	± 0.5	± 1	± 1	± 1	± 1
β [°]	30	30	30	30	32	32

Order Number

Without additional parts ⁹⁾	0	Connection cable	0 Without additional parts
Hand release ⁹⁾	1		1 Cover
Release monitoring, mechanical	2		2 Tacho attachment
Release monitoring, contactless ¹⁰⁾	A		3 Cover / tacho attachment
Hand release / release monitoring, mechanical	3		<div style="border: 1px solid black; padding: 5px;"> <p>Coil voltage [VDC]</p> <p>24</p> <p>104</p> <p>180</p> <p>207</p> <p> We recommend connection via smoothed DC voltage or a mayr®-bridge rectifier.</p> </div>
Hand release / release monitoring, contactless ¹⁰⁾	B		
Flange plate ⁹⁾	4		
Flange plate / hand release ⁹⁾	5		
Flange plate / hand release / release monitoring, mechanical	6		
Flange plate / hand release / release monitoring, contactless ¹⁰⁾	C		
Flange plate / release monitoring, mechanical	7		
Flange plate / release monitoring, contactless ¹⁰⁾	D		

_ / 8 9 6 . _	_ . 3	_ / _ / _ / _	_ / _ / _ / _	_ / _ / _ / _
<p>Sizes 4 to 100</p>	<p>Dual circuit brake 0</p> <p>Single circuit brake 1</p>	<p>0 Nominal braking torque 100 %</p> <p>1 Braking torque adjustment 120 %</p> <p>2 Braking torque adjustment 75 %</p>	<p>Hub bore Ø d^{H7}</p> <p>(Dimensions page 6)</p>	<p>Keyway acc. DIN 6885/1 or 6885/3</p>

Example: 100 / 896.001.30 / 24 / 40 / 6885/1

7) Hand release lever, round

8) Flush hub position (misalignment "x" permitted)

9) Only the brakes with release monitoring meet the requirements acc. BGV C 1 or DIN 56950-1 (Types 896._.2.3_ / 896._.A.3_ / 896._.3.3_ / 896._.B.3_ / 896._.6.3_ / 896._.C.3_ / 896._.7.3_ / 896._.D.3_).

10) Contactless release monitoring device available from Size 8.

The standard contactless release monitoring device is designed as an NO contact; cable length standard: 1 m (Sizes 8 – 100).

ROBA-stop[®]-silenzio[®] Type 896.0₁...3 – Sizes 200 to 1800

Noises < 50 dB(A) (Sound pressure level measurement) at nominal braking torque

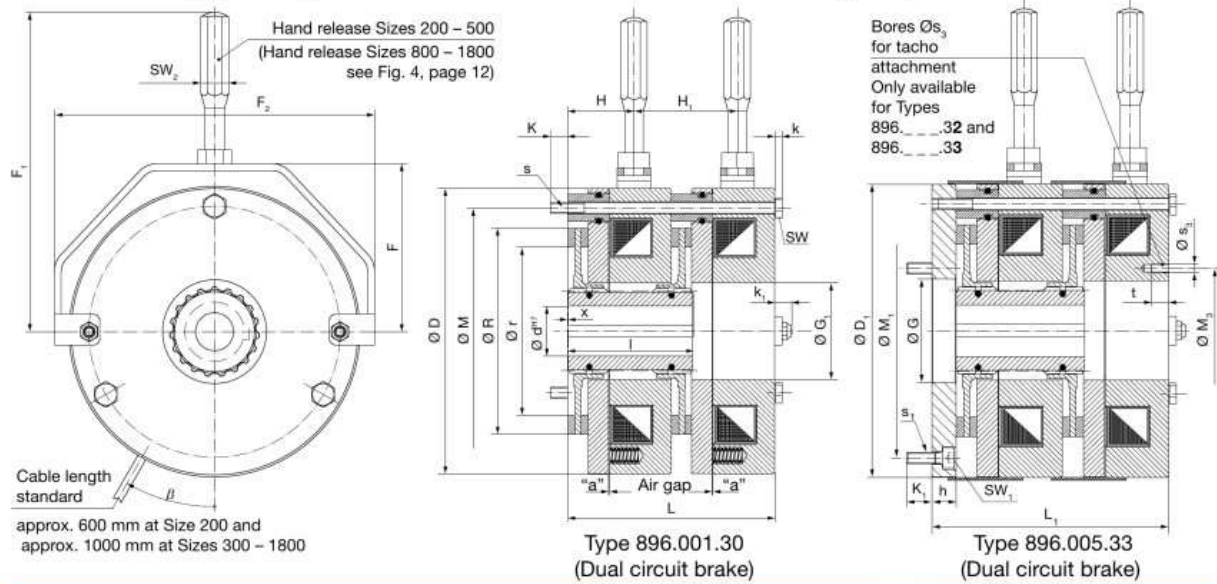

Technical Data			Size						
			200	300	500	800	1300	1800	
Nominal braking torque ¹⁾	Type 896.00...3	M _N	[Nm]	2 x 200	2 x 300	2 x 500	2 x 800	2 x 1300	2 x 1800
	Type 896.10...3	M _N	[Nm]	200	300	500	800	1300	1800
Electrical power	Type 896.00...3	P ₂₀	[W]	2 x 78	2 x 86	2 x 90	2 x 107	2 x 130	2 x 150
	Type 896.10...3	P ₂₀	[W]	78	86	90	107	130	150
Maximum speed		n _{max}	[rpm]	1700	1500	1300	1150	1000	900
Weight (pilot bored)	Type 896.000.3		[kg]	2 x 15.3	2 x 23	2 x 29	2 x 43.5	2 x 59.2	2 x 79.9
Nominal air gap (tolerance ± 0.07)		a	[mm]	0.5	0.5	0.5	0.5	0.5	0.5

¹⁾ Braking torque tolerance: + 0 % / + 60 %. For other braking torque adjustments: see Table below.

Braking Torque Adjustment [Nm]		Size					
		200	300	500	800	1300	1800
Dual circuit brake Type 896.0...3							
100 %		2 x 200	2 x 300	2 x 500	2 x 800	2 x 1300	2 x 1800
120 %		2 x 240	2 x 360	2 x 600	2 x 1000	2 x 1560	2 x 2150
75 %		2 x 150	2 x 225	2 x 380	2 x 600	2 x 980	2 x 1350
Single circuit brake Type 896.1...3							
100 %		200	300	500	800	1300	1800
120 %		240	360	600	1000	1560	2150
75 %		150	225	380	600	980	1350

i At a braking torque adjustment of 120 % (for Sizes 500 and 800) overexcitation (1.5 to 2 x the nominal voltage) is required for safe and fast release, using our ROBA[®]-switch fast acting rectifier (please contact mayr[®] power transmission if necessary).

Bores [mm]		Size						
		200	300	500	800	1300	1800	
Dual circuit brake Type 896.0...3								
Braking torque adjustment	100 %	d _{min}	25	35	45	53	66	76
		d _{max}	50 ²⁾	60 ³⁾	70 ⁴⁾	75	90	100 ⁵⁾
	120 %	d _{min}	29	40	50	65	75	85
		d _{max}	50 ²⁾	60 ³⁾	65	75	90	95
	75 %	d _{min}	23	26	40	45	56	66
		d _{max}	50 ²⁾	60 ³⁾	70 ⁴⁾	75	90	100 ⁵⁾
Single circuit brake Type 896.1...3								
Braking torque adjustment	100 %	d _{min}	30	32	45	53	66	77
		d _{max}	50 ²⁾	60 ³⁾	70 ⁴⁾	75	90	100 ⁵⁾
	120 %	d _{min}	35	38	50	65	75	85
		d _{max}	48	60 ³⁾	65	75	90	95
	75 %	d _{min}	24	24	40	45	56	66
		d _{max}	50 ²⁾	60 ³⁾	70 ⁴⁾	75	90	100 ⁵⁾

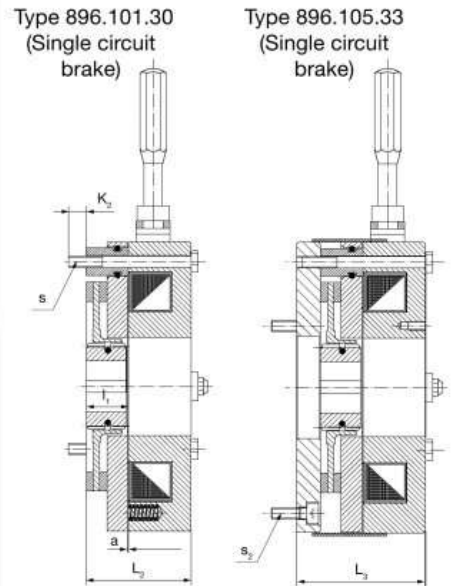

2) over Ø 48 keyway acc. DIN 6885/3
 3) over Ø 56 keyway acc. DIN 6885/3
 4) over Ø 65 keyway acc. DIN 6885/3
 5) over Ø 95 keyway acc. DIN 6885/3

Types 896.0₁...3 - Sizes 200 to 1800

We reserve the right to make dimensional and constructional alterations.

Dimensions	Size					
	200	300	500	800	1300	1800
Ø D	223	261	285	329	370	415
Ø D ₁	223	264	288	332	373	418
F	126.5	148	166.5	on request	on request	on request
F ₁	325.5	487.5	705.5	on request	on request	on request
F ₂	256	296	310	on request	on request	on request
Ø G	84	96	114	135	146	160
Ø G ₁	84	96	114	135	146	160
H	48	50.5	28.5	on request	on request	on request
H ₁	76	79.5	86	on request	on request	on request
h	19	21	28	31	30	36
K	16.4	18.7	25.5	28	28	32
K ₁	18	18	19	22	27	26
K ₂	12.2	18.1	21.5	22.5	27.5	24.5
k	8.4	10	10	13	13	13
k ₁	18	21	19	on request	on request	on request
L	152	159	172	189	199	205
L ₁	171	180	200	220	229	241
L ₂	76	79.5	86	94.5	99.5	102.5
L ₃	95	100.5	114	125.5	129.5	138.5
I	88	93	102	122	142	152
I ₁	35	50	50	60	70	75
Ø M	196	230	250	290	330	370
Ø M ₁	196	230	250	290	330	370
Ø M ₃	100	112	145	165	175	200
Ø R	170	188	213	246	283.5	320
Ø r	122	135	150	180	208	230
s	Type 896.0...3	3 x M10	3 x M12	6 x M12	6 x M16	8 x M16
	Type 896.1...3	3 x M10	3 x M12	3 x M12	3 x M16	4 x M16
s ₁	6 x M10	6 x M12	6 x M16	6 x M16	8 x M16	8 x M20
s ₂	3 x M10	3 x M12	3 x M16	3 x M16	4 x M16	4 x M20
s ₃	3 x M6	3 x M6	6 x M8	6 x M8	6 x M8	6 x M8
SW	16	18	18	24	24	24
SW ₁	8	10	14	14	14	17
SW ₂	14	17	Ø 25 ⁶⁾	on request	on request	on request
t	10	10	13	13	13	13
x ⁷⁾	± 1	± 1	± 1	± 0.5	± 1	± 1
β [°]	32	31	25	25	25	25

Order Number

Without additional parts ⁸⁾	0	Connection cable	0	Without additional parts
Hand release ⁸⁾	1		1	Cover
Release monitoring, mechanical	2		2	Tacho attachment
Release monitoring, contactless ⁹⁾	A		3	Cover / tacho attachment
Hand release / release monitoring, mechanical	3			
Hand release / release monitoring, contactless ⁹⁾	B			
Flange plate ⁸⁾	4			
Flange plate / hand release ⁸⁾	5			
Flange plate / hand release / release monitoring, mechanical	6			
Flange plate / hand release / release monitoring, contactless ⁹⁾	C			
Flange plate / release monitoring, mechanical	7			
Flange plate / release monitoring, contactless ⁹⁾	D			

Coil voltage [VDC]

24

104

180

207

We recommend connection via smoothed DC voltage or a mayr[®]-bridge rectifier.



Example: 200 / 896.001.30 / 24 / 40 / 6885/1

- 6) Hand release lever, round
- 7) Flush hub position (misalignment "x" permitted)
- 8) Only the brakes with release monitoring meet the requirements acc. BGV C 1 or DIN 56950-1 (Types 896...2.3 / 896...A.3 / 896...3.3 / 896...B.3 / 896...6.3 / 896...C.3 / 896...7.3 / 896...D.3.)
- 9) The standard contactless release monitoring device is designed as an NO contact; cable length standard: 1 m (Size 200) or 2 m (Sizes 300 – 1800).

ROBA-stop®-silenzio® Double rotor design Type 896.2...3 – Sizes 300 to 1800

Noises < 65 dB(A) (Sound pressure level measurement) at nominal braking torque

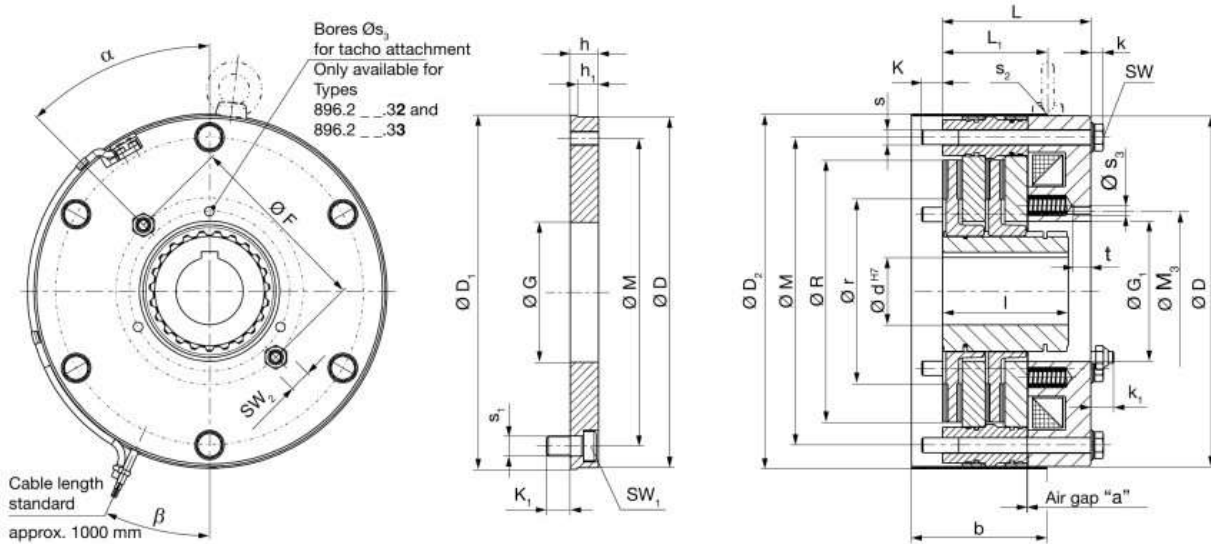

Technical Data				Size				
				300	500	800	1300	1800
Nominal braking torque ¹⁾	Type 896.20...3	M_N	[Nm]	600	1000	1600	2600	3600
Electrical power	for overexcitation ²⁾	P_{20}	[W]	348	352	412	500	552
	for nominal voltage	P_{20}	[W]	87	88	103	125	138
Maximum speed		n_{max}	[rpm]	300	300	300	250	250
Weight	without flange plate		[kg]	33	44	67	93	121
	with flange plate		[kg]	40.5	53	80	113	153
Nominal air gap (tolerance +0.15/-0.1)		a	[mm]	0.55	0.55	0.55	0.7	0.7

1) Braking torque tolerance: + 0 % / + 60 %. For other braking torque adjustments: see Table below.

2) When using a ROBA®-switch

Braking Torque Adjustment [Nm]

	Size				
	300	500	800	1300	1800
100 %	600	1000	1600	2600	3600
120 %	720	1200	2000	3120	4300
75 %	450	760	1200	1960	2700



At nominal braking torque 100 % (for Sizes 500 and 800) and at a braking torque adjustment of 120 % (for all Sizes) overexcitation (1.5 to 2 x the nominal voltage) is required for safe and fast release, using our ROBA®-switch fast acting rectifier (please contact mayr® power transmission if necessary).

Bores [mm]

		Size				
		300	500	800	1300	1800
100 %	d_{min}	35	45	53	66	76
	d_{max}	60 ³⁾	70 ⁴⁾	75	90	100 ⁵⁾
120 %	d_{min}	40	50	65	75	85
	d_{max}	60 ³⁾	65	75	90	95
75 %	d_{min}	26	40	45	56	66
	d_{max}	60 ³⁾	70 ⁴⁾	75	90	100 ⁵⁾

3) over Ø 56 keyway acc. DIN 6885/3

5) over Ø 95 keyway acc. DIN 6885/3

4) over Ø 65 keyway acc. DIN 6885/3

Type 896.2 _ .3_ – Sizes 300 to 1800

We reserve the right to make dimensional and constructional alterations.

Dimensions	Size				
	300	500	800	1300	1800
b	90	102	114	125	130
Ø D	261	285	329	370	415
Ø D ₁	264	288	332	373	418
Ø D ₂	264	288	332	373	418
Ø F	209	152	181	197	225
Ø G	96	114	135	146	160
Ø G ₁	96	114	135	146	160
h	21	28	31	30	36
h ₁	15	17	19	23	23
k	10	10	13	13	13
k ₁	21	19	25	25	24
K	18.1	16.9	23.3	23.3	28.3
K ₁	18	19	22	27	26
l	93	102	122	142	152
Please observe the load on the shaft or key.					
L	109.4	120.6	133.7	143.7	148.7
L ₁	74.4	85.6	93.7	106.7	110.7
Ø M	230	250	290	330	370
Ø M ₃	112	145	165	175	200
Ø r	135	150	180	208	230
Ø R	188	213	246	283.5	320
s	3 x M12	6 x M12	6 x M16	8 x M16	8 x M16
s ₁	6 x M12	6 x M16	6 x M16	8 x M16	8 x M20
s ₂ ⁶⁾	M10	M10	M10	M12	M12
s ₃	3 x M6	6 x M8	6 x M8	6 x M8	6 x M8
SW	18/19	18/19	24	24	24
SW ₁	10	14	14	14	17
SW ₂	16/17	16/17	18/19	24	24
t	10	13	13	13	13
α [°]	35	45	45	45	45
β [°]	31	25	25	25	25

Order Number

Without additional parts ⁷⁾	0	Connection cable	0 Without additional parts
Emergency hand release ⁷⁾	1		1 Cover
Release monitoring, mechanical	2		2 Tacho attachment
Release monitoring, contactless ⁸⁾	A		3 Cover / tacho attachment
Emergency hand release / release monitoring, mechanical	3		 Coil voltage [VDC] 16 24 104 180 207 We recommend connection via smoothed DC voltage or a mayr®-bridge rectifier.
Emergency hand release / release monitoring, contactless ⁸⁾	B		
Flange plate ⁷⁾	4		
Flange plate / emergency hand release ⁷⁾	5		
Flange plate / emergency hand release / release monitoring, mechanical	6		
Flange plate / emergency hand release / release monitoring, contactless ⁸⁾	C		
Flange plate / release monitoring, mechanical	7		
Flange plate / release monitoring, contactless ⁸⁾	D		

	/ 8 9 6 . 2	/ 3	/ / / /	
Sizes 300 to 1800	Nominal braking torque 100 % Braking torque adjustment 120 % Braking torque adjustment 75 %	0 1 2	Hub bore Ø d ^{H7} (Dimensions page 10)	Keyway acc. DIN 6885/1 or 6885/3
 At nominal braking torque 100 % (for Sizes 500 and 800) and at a braking torque adjustment of 120 % (for all Sizes) overexcitation (1.5 to 2 x the nominal voltage) is required for safe and fast release, using our ROBA®-switch fast acting rectifier (please contact mayr® power transmission if necessary).				

Example: 800 / 896.205.30 / 104 / 70 / 6885/1

6) Eyebolt (installation aid, not included in delivery)
 7) Only the brakes with release monitoring meet the requirements acc. BGV C 1 or DIN 56950-1 (Types 896.2_2.3_ / 896.2_A.3_ / 896.2_3.3_ / 896.2_B.3_ / 896.2_6.3_ / 896.2_C.3_ / 896.2_7.3_ / 896.2_D.3_).
 8) The standard contactless release monitoring device is designed as an NO contact; cable length standard: 2 m.

ROBA-stop®-silenzio® – Short Description Installation Type 896.0_...3_

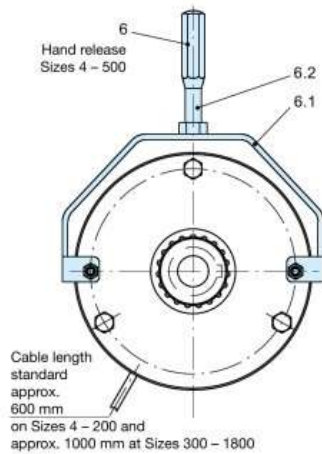

Fig. 1

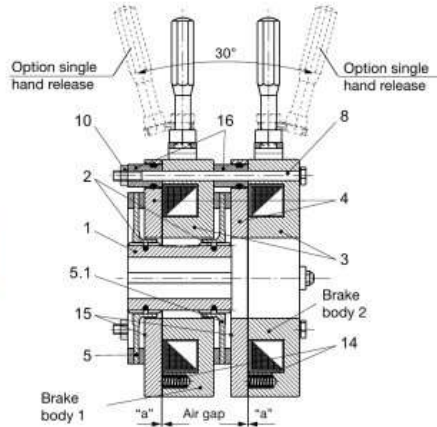

Fig. 2 (Dual circuit brake)

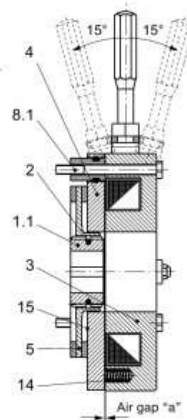

Fig. 3 (Single circuit brake)

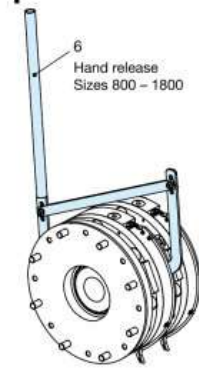

Fig. 4

Parts List (Only use mayr® original parts)

- | | | | |
|-----|---------------------------------|-----|----------------------|
| 1 | Hub assembly with 2 O-rings (2) | 8 | Hexagon head screw |
| 1.1 | *Hub assembly with 1 O-ring (2) | 8.1 | **Hexagon head screw |
| 2 | O-ring | 10 | Transportation lock |
| 3 | Coil carrier assemblies 1 and 2 | 14 | Thrust spring |
| 4 | Armature disks 1 and 2 | 15 | Shoulder screw |
| 5 | Rotor 1 | 16 | Distance bolt |
| 5.1 | Rotor 2 | | |
| 6 | Hand release assembly | | |
| 6.1 | Switch bracket | | |
| 6.2 | Hand release rod | | |
- * Only on single circuit brake designs
** Sizes 4 – 300 only on single circuit brake designs

Installation Conditions (Figs. 1, 2 and 3)

- The eccentricity of the shaft end in relation to the mounting pitch circle must not exceed 0.2 mm.
- The positional tolerance of the threads for the hexagon head screws (8 and 8.1) must not exceed 0.2 mm.
- The axial run-out deviation of the screw-on surface to the shaft must not exceed the permitted axial run-out tolerance acc. DIN 42955 R. The reference diameter is the pitch circle diameter for securement of the brakes. Larger deviations can lead to a drop in torque, to continuous grinding of the rotor and to overheating.
- The tolerances of the hub (1) and the shaft must be selected so that no widening of the hub (1) toothing can occur, as widening of the toothing leads to the rotors (5 and 5.1) jamming on the hub (1) and therefore to brake malfunctions (recommended hub – shaft tolerance H7/k6).
- The rotors (5 and 5.1) and brake surfaces must be oil and grease-free. A suitable counter friction surface (steel or cast iron) must be used. Sharp-edged interruptions on the friction surfaces must be avoided. Recommended surface quality in the area of the friction surface Ra = 1.6 µm. In particular customer-side mounting surfaces made of grey cast iron are to be rubbed down additionally with fine sandpaper (grain 400).

Short Description (Figs. 1 and 2)

Please find a detailed installation description in the Installation and Operational Instructions for the product (also at www.mayr.com).

- Mount the hub assembly with the O-rings (Item 1 / O-rings must be slightly greased) onto the shaft, bring it into the correct position (the length of the key should lie over the entire hub) and secure it axially (e.g. using a locking ring).
- Push rotor 1 (5) by hand using light pressure over both O-rings (2) onto the hub (1), so that the friction lining of rotor 1 (5) lies against the machine wall (the rotor collar should be facing away from the machine wall). Check that the toothing moves easily. Do not damage the O-rings.
- Push brake body 1 over hub (1) and rotor collar of rotor 1 (5) (the fixing holes should align with the threaded holes in the machine wall).
- Push rotor 2 (5.1) by hand using light pressure over an O-ring (2) onto the hub (1), so that the friction lining of rotor 2 (5.1) lies against the brake body 1 (the rotor collar should be facing the machine wall). Check that the toothing moves easily. Do not damage the O-ring.
- Insert the hexagon head screws (8) into the bores in brake body 2, which are equipped with distance bolts (16), and then join with brake body 1 and screw onto the machine wall. Tighten the hexagon head screws (8) evenly all around using a torque wrench to a tightening torque acc. Table 1.
- Inspect air gaps "a" according to Table 1.**
The nominal air gap must be given.

Hand Release

A hand release (6) is installed manufacturer-side, dependent on Size and Type (see Type key pages 7 and 9 and Table 1). From Size 800, both circuits are released simultaneously with a lever (see Fig. 4).

Technical Data – Installation		Size												
		4	8	16	32	64	100	200	300	500	800	1300	1800	
Nominal air gap	a	[mm]	0.45 ± 0.07	0.5 ± 0.07	0.5 ± 0.07	0.5 ± 0.07	0.5 ± 0.07	0.5 ± 0.07	0.5 ± 0.07	0.5 ± 0.07	0.5 ± 0.07	0.5 ± 0.07	0.5 ± 0.07	0.5 ± 0.07
	F	[N]	35	35	110	100	130	200	250	250	300	approx. 300	approx. 320	approx. 350
Actuation Angle Hand release	α	[°]	15	15	15	15	15	15	15	15	-	-	-	-
Tightening torque Fixing screw Item 8	T _A	[Nm]	3	5	10	13	30	36	71	123	123	250	250	300

Table 1

ROBA-stop®-silenzio® – Brake Dimensioning

Brake Size Selection

1. Brake selection

$$M_{\text{erf.}} = \frac{9550 \times P}{n} \times K \leq M_N \quad [\text{Nm}]$$

$$t_v = \frac{J \times n}{9.55 \times M_v} \quad [\text{s}]$$

$$t_d = t_v + t_1 \quad [\text{s}]$$

$$M_v = M_N + (-) \cdot M_L \quad [\text{Nm}]$$

2. Inspection of thermic load

$$Q_r = \frac{J \times n^2}{182.4} \times \frac{M_N}{M_v} \quad [\text{J/braking}]$$

The permitted friction work (switching work) $Q_{r,zul}$ per braking for the specified switching frequency can be taken from the friction-power diagrams (page 14).

If the friction work per braking is known, the max. switching frequency can also be taken from the friction-power diagrams (page 14).

Key:

- J [kgm²] Mass moment of inertia
- K [-] Safety factor (1 – 3 x according to conditions)
- $M_{\text{erf.}}$ [Nm] Required braking torque
- M_v [Nm] Delaying torque
- M_L [Nm] Load torque on system * sign in brackets (-) is valid if load is braked during downward
- M_N [Nm] Nominal torque (Technical Data pages 6 – 10)
- n [rpm] Speed
- P [kW] Input power
- t_v [s] Braking action
- t_1 [s] Connection time (Table 4, page 16)
- t_d [s] Total switch-on time
- Q_r [J] Friction work present per braking
- $Q_{r,0.1}$ [J] Friction work per 0.1 mm wear (Table 2)
- $Q_{r,ges.}$ [J] Friction work up to rotor replacement (Table 2)
- $Q_{r,zul}$ [J] Permitted friction work (permitted switching work) per braking (page 14)



Due to operating parameters such as sliding speed, pressing or temperature the **wear values** can **only be considered guideline values**.

Friction Work				Size											
				4	8	16	32	64	100	200	300	500	800	1300	1800
per 0.1 mm wear	Type 896.....	$Q_{r,0.1}$	[10 ⁶ J]	22	28	56	73	116	155	227	269	215	249	357	447
up to rotor replacement	Type 896.....	$Q_{r,ges.}$	[10 ⁶ J]	33	112	336	365	464	465	1135	1345	860	747	1428	1788

Table 2

Mass Moment of Inertia Rotor + hub with d_{max}				Size											
				4	8	16	32	64	100	200	300	500	800	1300	1800
ROBA-stop®-silenzio®															
	Type 896.00_3_	J_{R+H}	[10 ⁻⁴ kgm ²]	0.316	0.799	2.40	6.11	11.9	23.7	58.1	89.1	188	389	695	1110
	Type 896.10_3_	J_{R+H}	[10 ⁻⁴ kgm ²]	0.156	0.393	1.14	2.92	5.82	11.3	28.3	46	93.5	193	348	558
Double rotor design															
	Type 896.20_3_	J_{R+H}	[10 ⁻⁴ kgm ²]	-	-	-	-	-	-	-	89.1	188	389	695	1110

Table 3

ROBA-stop®-silenzio® – Friction-Power Diagrams

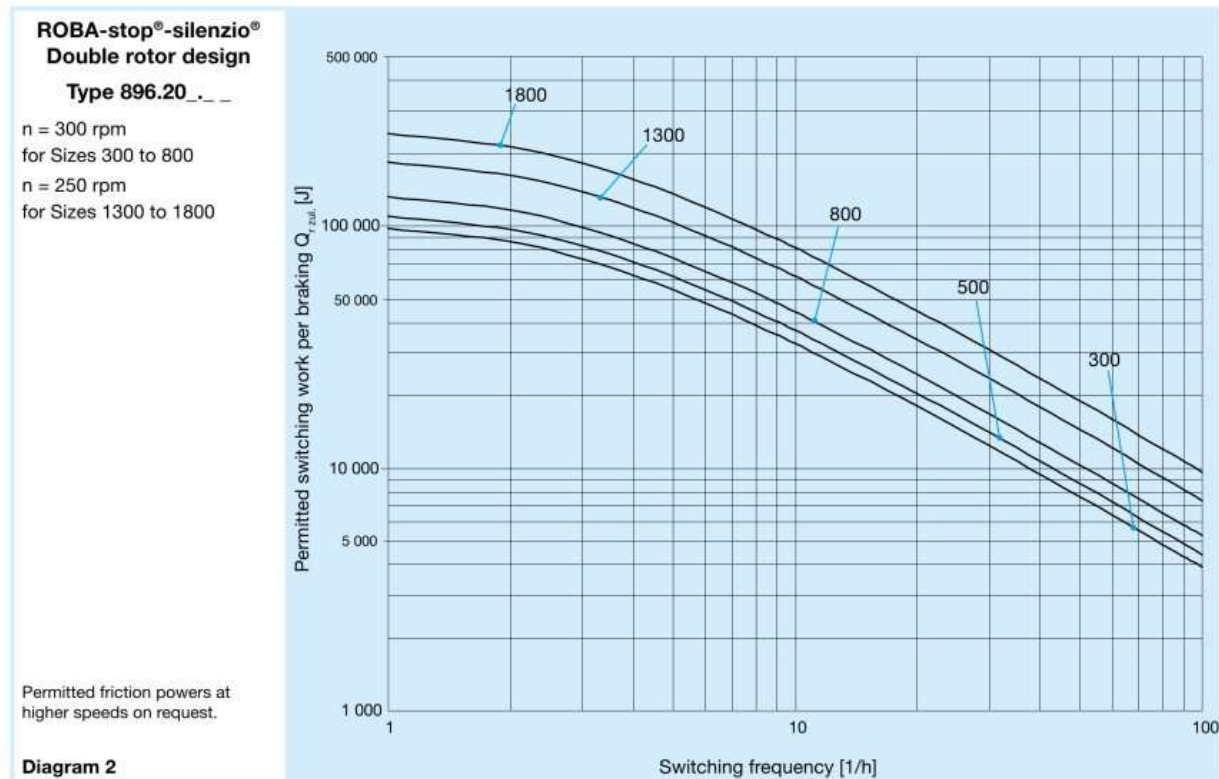
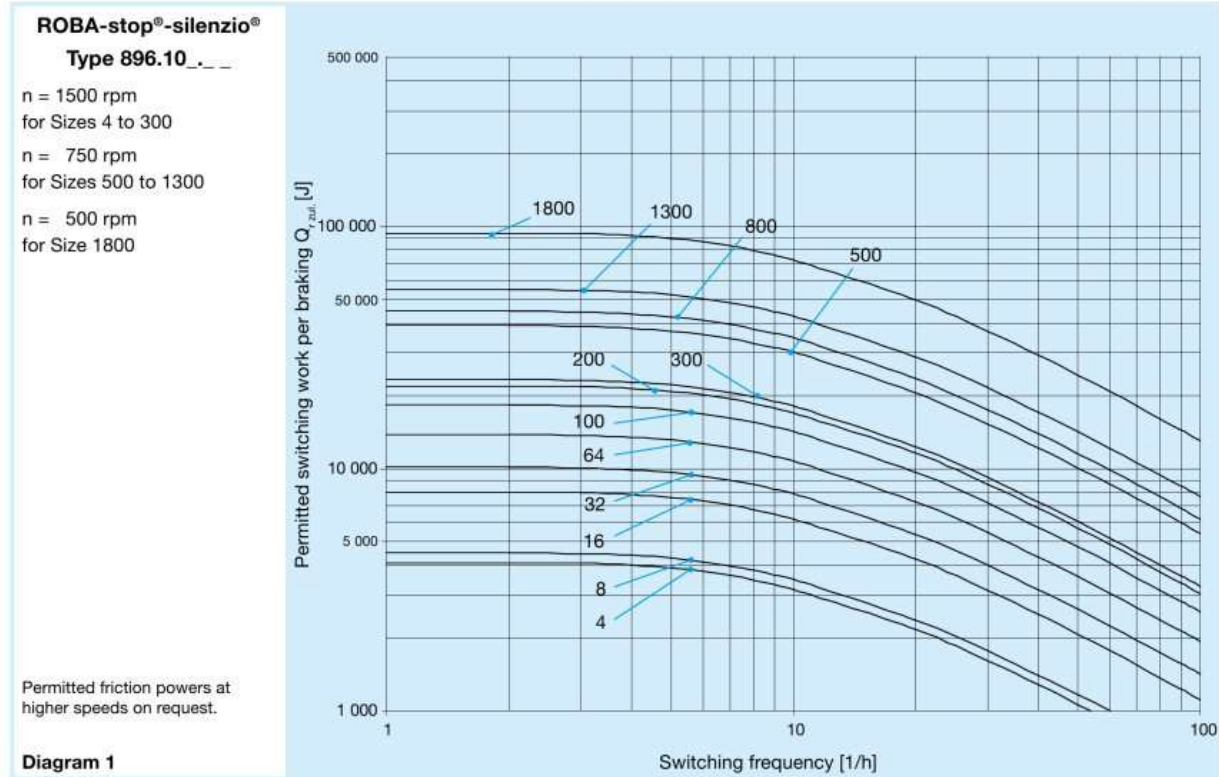

ROBA-stop®-silenzio® – Further Options

In addition to the standard brakes, *mayr*® power transmission provides a multitude of further designs, which cannot be described in detail in this catalogue.

Some of the most frequently requested options are:

- IP65 design with cover
- Dust-proof design with cover and cover plate
- Directly toothed shaft
- Terminal box
- ROBA®-ES-attachment
- Customer-specific flange plate

Please contact *mayr*® for further information

IP65 design

The enclosed design (IP65) is equipped with a cover (Item 1).

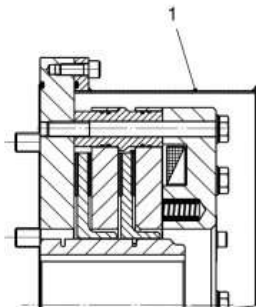

Fig. 5

Terminal box

Terminal box (Item 1) for the wiring and storage of rectifiers (ROBA®-switch, bridge rectifier).

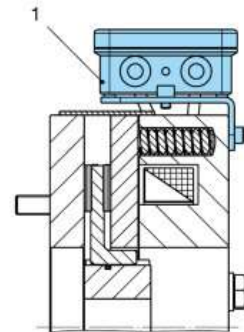

Fig. 8

Dust-proof design

The dust-proof design is equipped with a cover (Item 1) and with a cover plate (Item 2).

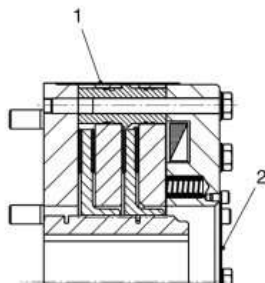

Fig. 6

ROBA®-ES-attachment

Space-saving connection of a ROBA®-ES shaft coupling (Item 1) directly onto the hub. The flexible shaft coupling of the ROBA®-ES Type series compensates for shaft misalignments and is vibration-damping.

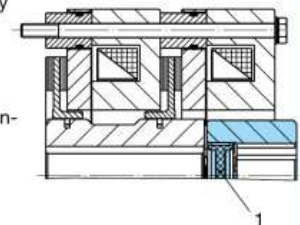

Fig. 9

Directly toothed shaft

Directly toothed shaft (Item 1) for larger shaft diameters and higher transmittable torques.

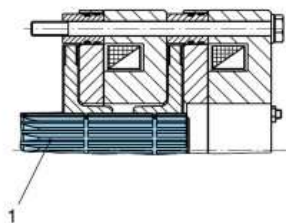

Fig. 7

Special flange plate

We offer a range of flange plates for customer-specific solutions, such as for example the special flange plate shown in Fig. 10 (Item 1) with customer-tailored centering (Item 2).

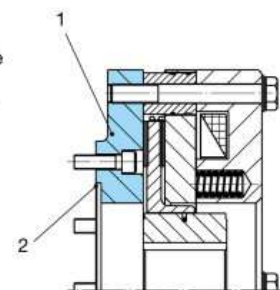

Fig. 10

ROBA-stop®-silenzio® – Switching Times

The switching times are only valid for the braking torques stated in the catalogue.

According to directive VDI 2241, the switching times are measured at a sliding speed of 1 m/s with reference to a mean friction radius. The brake switching times are influenced by the temperature, by the air gap between the armature disk and the coil carrier, which depends on the wear status of the linings, and by the type of voltage-limiting components.

The values stated in the Table are mean values which refer to the nominal air gap and the nominal torque on a warm brake.

Typical switching time tolerances are ± 20 %.

Please Observe: DC-side switching

When measuring the DC-side switching times (t_{11} – time), the inductive switch-off voltage peaks are according to VDE 0580 limited to values smaller than 1200 volts. If other voltage-limiting components and constructional elements are installed, this switching time t_{11} and therefore also switching time t_1 increase.

Switching Times Types 896_0_ _ _			Size											
			4	8	16	32	64	100	200	300	500	800	1300	1800
Nominal braking torque	Type 896.10_ _ _	M_N [Nm]	4	8	16	32	64	100	200	300	500	800	1300	1800
Connection time	DC-side switching	t_1 [ms]	33	46	99	121	110	160	190	245	260	270	270	300
	AC-side switching	t_1 [ms]	135	196	398	518	447	488	968	1087	1133	1231	1464	1920
Response delay on connection	DC-side switching	t_{11} [ms]	6	9	20	32	34	35	60	60	65	65	80	100
	AC-side switching	t_{11} [ms]	52	79	145	229	164	154	412	429	518	531	588	800
Separation time		t_2 [ms]	52	70	94	120	174	234	270	308	444	581	589	850

Table 4: Switching Times Type 896_0_ _ _ : ROBA-stop®-silenzio®, Double Rotor design from Size 300

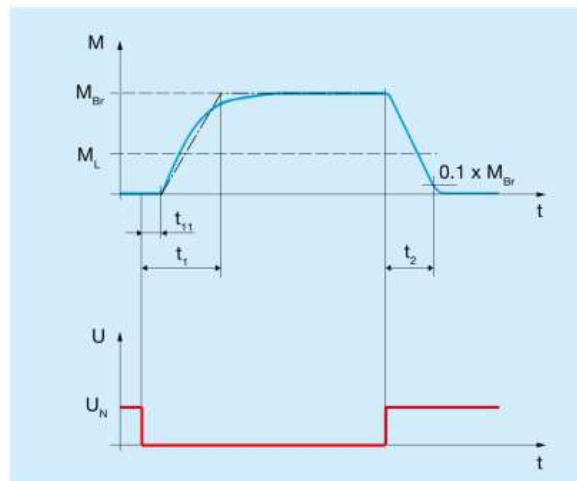

Key:

- M_{Br} = Braking torque
- M_L = Load torque
- t_1 = Connection time
- t_{11} = Response delay on connection
- t_2 = Separation time
- U_N = Coil nominal voltage

Diagram 4: Torque-Time Diagram



EN 81-A3
-conform

Switching times for the elevator industry acc. ESV Type Examination Certificate on request.

ROBA-stop®-silenzio® – Electrical Connection

Electrical Connection and Wiring

DC current is necessary for operation of the brake. The coil voltage is indicated on the Type tag as well as on the brake body and is designed according to the DIN IEC 60038 ($\pm 10\%$ tolerance). Operation can take place with alternating voltage using a rectifier or another suitable DC power supply. The connection possibilities can vary dependent on the brake equipment. Please follow the exact connections according to the Wiring Diagram. The manufacturer and the user must observe the applicable regulations and standards (e.g. DIN EN 60204-1 and DIN VDE 0580). Their observance must be guaranteed and double-checked!



Supply voltage requirements **when operating** noise-damped brakes

In order to minimise **noise development of the released brake**, it must only be operated via DC voltage with low ripple content. AC current operation can take place using a **bridge rectifier** or another suitable DC power supply. Supplies whose output voltages have a high ripple content (e.g. a half-wave rectifier, phase angle control systems, ...) are not suitable for operation of the brake.

At variance with this, brakes specially dimensioned for overexcitation must be operated with the ROBA®-switch fast acting rectifier.

Earthing Connection

The brake is designed for Protection Class I. This protection covers not only the basic insulation, but also the connection of all conductive parts to the protective conductor (PE) on the fixed installation. If the basic insulation fails, no contact voltage will remain. Please carry out a standardised inspection of the protective conductor connections to all contactable metal parts!

Device Fuses

To protect against damage from short circuits, please add suitable device fuses to the mains cable.

Switching Behaviour

The safe operational behaviour of a brake is to a large extent dependent on the switching mode used. Furthermore, the switching times are influenced by the temperature and the air gap between the armature disk and the coil carrier (dependent on the wear condition of the linings).

Magnetic Field Build-up

When the voltage is switched on, a magnetic field is built up in the brake coil, which attracts the armature disk to the coil carrier and releases the brake.

• Field Build-up with Normal Excitation

If the magnetic coil is energised with nominal voltage, the coil current does not immediately reach its nominal value. The coil inductivity causes the current to increase slowly as an exponential function. Accordingly, the build-up of the magnetic field takes place more slowly and the braking torque drop (curve 1, Fig. above) is also delayed.

• Field Build-up with Overexcitation

A quicker drop in braking torque is achieved if the coil is temporarily placed under a higher voltage than the nominal voltage, as the current then increases more quickly. Once the brake is released, it needs to be switched over to the nominal voltage (curve 2, Fig. above). The relationship between overexcitation and separation time t_2 is roughly indirectly proportional. This means that, using overexcitation voltage U_o (= doubled nominal voltage U_N), the separation time t_2 for release of the brake is halved. The ROBA®-switch fast acting rectifier works on this principle.

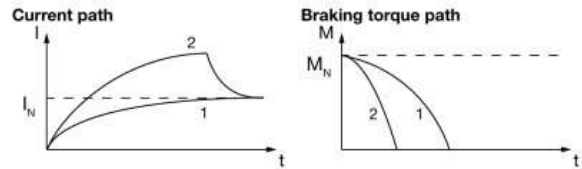

Operation with overexcitation requires an inspection of :

- the required overexcitation time *
- as well as the RMS coil capacity ** with a cycle frequency higher than 1 cycle per minute.

* Overexcitation time t_o

Increased wear, and therefore an increasing air gap as well as coil heating lengthen the separation times t_2 for the brake. For this reason, at least double the separation time t_2 at nominal voltage must be selected as overexcitation time t_o on each brake size

The spring forces also influence the brake separation times t_2 : Higher spring forces increase the separation times t_2 and lower spring forces reduce the separation times t_2 .

- **Spring force (braking torque adjustment) < 100 %:**

The overexcitation time t_o is less than the doubled separation time t_2 on each brake size.

- **Spring force (braking torque adjustment) = 100 %:**

The overexcitation time t_o equals the doubled separation time t_2 on each brake size.

- **Spring force (braking torque adjustment) > 100 %:**

The overexcitation time t_o is higher than the doubled separation time t_2 on each brake size.

** RMS coil capacity P



$$P \leq P_N$$

The coil capacity P must not be larger than P_N . Otherwise the coil may fail due to thermic overload.

Calculations:

P [W] RMS coil capacity dependent on switching frequency, overexcitation and duty cycle

$$P = \frac{P_o \times t_o + P_N \times t_N}{T}$$

P_N [W]

P_o [W]

Coil nominal capacity (catalogue values, Type tag)

Coil capacity on overexcitation

$$P_o = \left(\frac{U_o}{U_N} \right)^2 \times P_N$$

t_o [s]

t_N [s]

t_{off} [s]

t_{on} [s]

T [s]

U_o [V]

U_N [V]

Overexcitation time
Time of operation with coil nominal voltage
Time without voltage
Time with voltage
Total time ($t_o + t_N + t_{on}$)
Overexcitation voltage (bridge voltage)
Coil nominal voltage

Time Diagram:

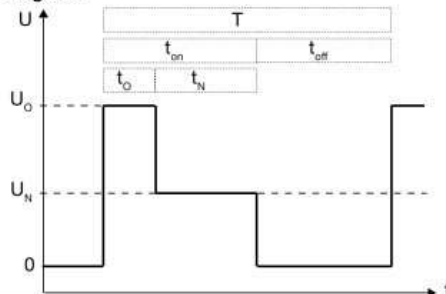

ROBA-stop®-silenzio® – Electrical Connection

Magnetic Field Removal

• AC-side Switching

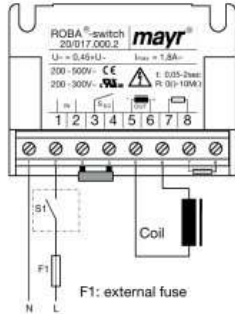

The power circuit is interrupted in front of the rectifier. The magnetic field slowly reduces. This delays the rise in braking torque.

When switching times are not important, please switch AC-side, as no protective measures are necessary for the coil and the switching contacts.

AC-side switching means **low-noise switching**; however, the brake engagement time is longer (approx. 6 – 10 times longer than with DC-side switch-off), use for non-critical braking times.

• DC-side Switching

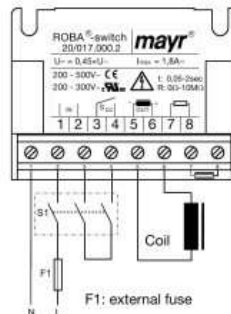

The power circuit is interrupted between the rectifier and the coil as well as mains-side. The magnetic field reduces extremely quickly. This causes a quick rise in braking torque.

When switching DC-side, high voltage peaks are produced in the coil, which lead to wear on the contacts from sparks and to destruction of the insulation.

DC-side switching means **short brake engagement times (e.g. for EMERGENCY STOP operation)**; however, louder switching noises.

• Protection Circuit

When using DC-side switching, the coil must be protected by a suitable protection circuit according to VDE 0580, which is integrated in *mayr*®-rectifiers. To protect the switching contact from consumption when using DC-side switching, additional protective measures are necessary (e.g. series connection of switching contacts). The switching contacts used should have a minimum contact opening of 3 mm and should be suitable for inductive load switching. Please make sure on selection that the rated voltage and the rated operating current are sufficient. Depending on the application, the switching contact can also be protected by other protection circuits (e.g. *mayr*®-spark quenching unit), although this may of course then alter the switching times.

Switching example

The *mayr*®-rectifiers shown in the Figure below serve as a switching example (e. g. combined switching for the elevator industry).

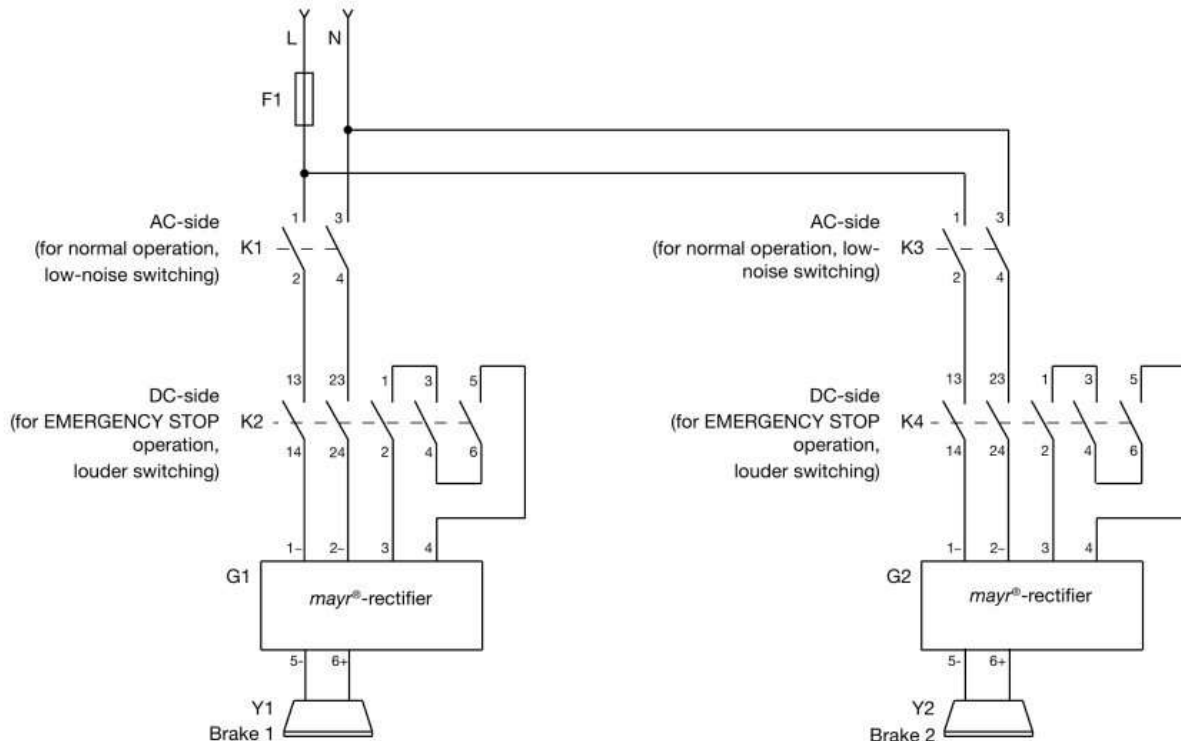

Contactless Release Monitoring

- **Wear-free**
- **Robust**
- **Magnetic field-resistant**
- **Absolutely reliable**

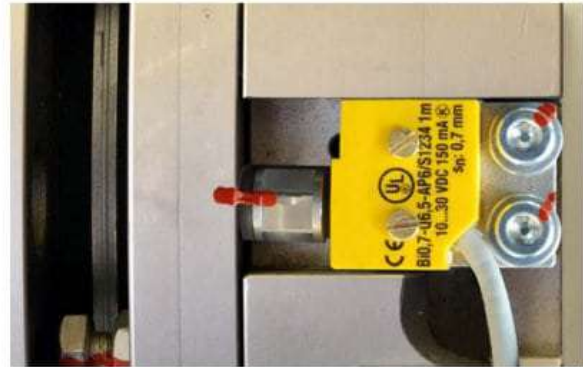

Function

Brakes in passenger elevators are subject to strict technical requirements. They have to guarantee the passengers' safety at all times. An indispensable element for safety brakes fulfilling the DIN EN 81 standard requirements is the integrated function monitoring. This release monitoring prevents unpermitted operating conditions, such as for example the motor starting up against closed brakes.

As an alternative to the tried and tested release monitoring with microswitches, *mayr*[®] power transmission, as the world-wide leading manufacturer of safety brakes in safety-critical applications such as passenger elevators or vertical axes, offer a contactless system with proximity switches. This fail-safe system with an inductive proximity switch registers the operating condition of the brake and authorises the motor to start up only after release. The contactless release monitoring guarantees maximum functional and operational safety.

Maximum Reliability and Accuracy

As there are no mechanical parts involved, the lifetime of this new, contactless release monitoring system is not dependent on the switching frequency. The system is magnetic field resistant and works absolutely reliably and wear-free. It is also resistant to impacts and vibrations, as there are no movable parts, and the electronics are completely encapsulated. Other advantages of the inductive proximity switch are the high switching point repetitive accuracy, the low hysteresis and the low temperature drift.

The switching bolt for the proximity switch is installed at the factory and is, in contrast to the release monitoring system with microswitch, not adjustable. Application errors through adjustment of the switching point position can be excluded. This feature, too, plays an important role in maximising functional and operational safety.

Optionally NO or NC Contacts

The contactless release monitoring system can be designed either as an NO or NC contact. With the NC contact function, the 'High' signal is generated if the brake is switched when de-energised. Here the armature disk drops and the brake closes. Initiator cable breakage is recognised when the brake is closed.

With the NO contact function, the 'High' signal is generated if the brake is energised and the armature disk releases the rotor. The brake is released. Only on generation of the 'High' signal is the motor enabled for start up. This reliably prevents the motor from starting up against a closed brake. Cable breakage is recognised when the brake is open.

Technical Data

Operating voltage	10 ... 30 VDC
DC rated operating current	< 150 mA
Ambient temperature	-25 up to +85 °C
Repetitive accuracy	< 0.015 mm
Hysteresis	< 0.025 mm
Temperature drift (-25 °C to +85 °C)	< +- 0.05 mm

Wiring Diagram

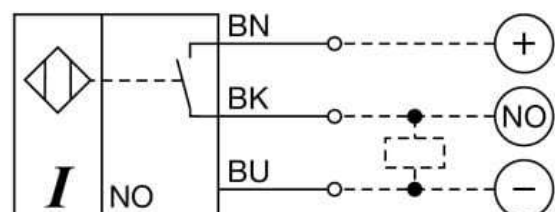

Electrical Accessories – Functions of the DC Voltage Modules

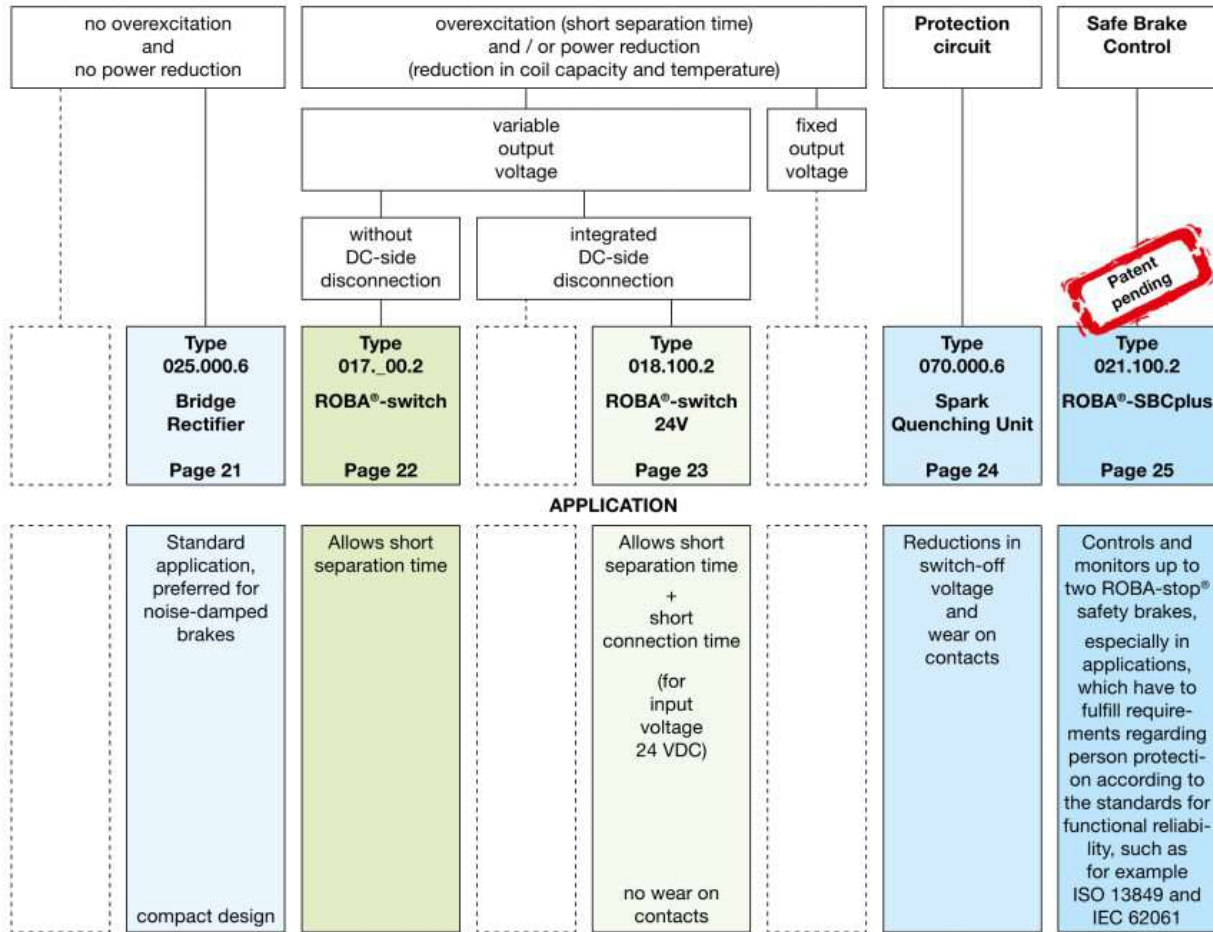

Example

Available: mains voltage 230 VAC
 Wanted: short separation time (overexcitation)
 Required: supply module / coil nominal voltage

Solution:

- Supply module: Type 017._00.2
- Coil nominal voltage: 104 VDC

For detailed information on our DC voltage modules, please go to: www.mayr.com

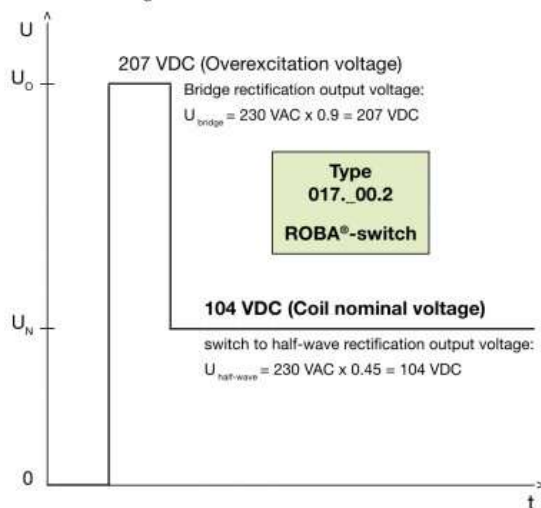

Bridge Rectifier Type 025.000.6



Application

Rectifiers are used to connect DC consumers to alternating voltage supplies, for example electromagnetic brakes and clutches (ROBA-stop[®], ROBA-quick[®], ROBATIC[®]), electromagnets, electrovalves, contactors, switch-on safe DC motors, etc.

Function

The AC input voltage (VAC) is rectified (VDC) in order to operate DC voltage units. Also, voltage peaks, which occur when switching off inductive loads and which may cause damage to insulation and contacts, are limited and the contact load reduced.



Electrical Connection (Terminals)

- 1 + 2 Input voltage
- 3 + 4 Connection for an external switch for DC-side switching
- 5 + 6 Coil
- 7 - 10 Free nc terminals (only for Size 2)

Dimensions (mm)

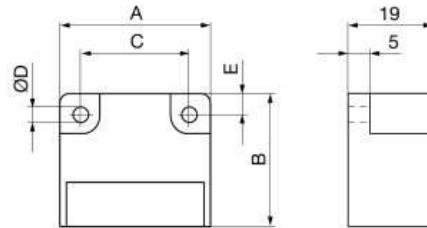

Size	A	B	C	ØD	E
1	34	30	25	3.5	4.5
2	54	30	44	4.5	5.0

Order Number

— / 0 2 5 . 0 0 0 . 6



- Size
- 1
- 2

Accessories: Mounting bracket set for 35 mm rail acc. EN 60715: Article-No. 1803201

Technical Data

			Bridge rectifier		
			VDC = VAC x 0.9		
Type			1/025	2/025	
Max. input voltage	± 10 %	U_{AC} [VAC]	230	230	
Max. output voltage		U_{DC} [VDC]	207	207	
Output current	≤ 50 °C	I_{RMS} [A]	2.5	2.5	
	max. 85 °C	I_{RMS} [A]	1.7	1.7	
Max. coil nominal capacity at	$U_{AC} = 115$ VAC	≤ 50 °C	P_N [W]	260	
		up to 85 °C	P_N [W]	177	
	$U_{AC} = 230$ VAC	≤ 50 °C	P_N [W]	517	
		up to 85 °C	P_N [W]	352	
	$U_{AC} = 400$ VAC	≤ 50 °C	P_N [W]	-	
		up to 85 °C	P_N [W]	-	
	$U_{AC} = 500$ VAC	≤ 50 °C	P_N [W]	-	
		up to 85 °C	P_N [W]	-	
	$U_{AC} = 600$ VAC	≤ 50 °C	P_N [W]	-	
		up to 85 °C	P_N [W]	-	
	Peak reverse voltage		[V]	1600	1600
	Rated insulation voltage		U_{RMS} [V _{RMS}]	320	320
Pollution degree (insulation coordination)			1	1	
Device fuses			To be included in the input voltage line.		
Recommended microfuse switching capacity H			FF 3.15 A	FF 3.15 A	
The microfuse corresponds to the max. possible connection capacity. If fuses are used corresponding to the actual capacities, the permitted limit integral Pt must be observed on selection.					
Permitted limit integral		Pt [A ² s]	40	40	
Protection			IP65 components, encapsulated / IP20 terminals		
Terminals			Cross-section 0.14 - 1.5 mm ² (AWG 26-14)		
Ambient temperature		[°C]	-25 up to +85		
Storage temperature		[°C]	-40 °C up to +85 °C		
Conformity markings			UL, CE	UL, CE	
Installation conditions			The installation position can be user-defined. Please ensure sufficient heat dissipation and air convection! Do not install near to sources of intense heat!		

ROBA[®]-switch Type 017._00.2



Application

ROBA[®]-switch fast acting rectifiers are used to connect DC consumers to alternating voltage supplies, for example electromagnetic brakes and clutches (ROBA-stop[®], ROBA[®]-quick, ROBATIC[®]) as well as electromagnets, electrovalves, etc.

Fast acting rectifier ROBA[®]-switch 017._00.2

- Consumer operation with overexcitation or power reduction
- Input voltage: 100 – 500 VAC
- Maximum output current I_{RMS} : 3 A at 250 VAC
- UL-approved

Function

The ROBA[®]-switch units are used for operation at an input voltage of between 100 and 500 VAC, dependent on size. They can switch internally from bridge rectification output voltage to half-wave rectification output voltage. The bridge rectification time can be modified from 0.05 to 2 seconds by exchanging the external resistor (R_{ext}).

Electrical Connection (Terminals)

- 1 + 2 Input voltage (fitted protective varistor)
- 3 + 4 Connection for external contact for DC-side switch-off
- 5 + 6 Output voltage (fitted protective varistor)
- 7 + 8 R_{ext} for bridge rectification time adjustment

Technical Data

Input voltage	see Table 1
Output voltage	see Table 1
Protection	IP65 components, IP20 terminals, IP10 R_{ext}
Terminal nom. cross-section	1.5 mm ² (AWG 22-14)
Ambient temperature	-25 °C up to +70 °C
Storage temperature	-40 °C up to +70 °C

ROBA[®]-switch Sizes, Table 1

		Size			
		Type 017.000.2		Type 017.100.2	
		10	20	10	20
Input voltage ± 10 %	U_{AC} [VAC]	100-250	200-500	100-250	200-500
Output voltage	U_{bridge} [VDC]	90-225	180-450	90-225	180-450
	$U_{half-wave}$ [VDC]	45-113	90-225	45-113	90-225
Output current at ≤ 45 °C	I_{RMS} [A]	2.0	1.8	3.0	2.0
	I_{RMS} [A]	1.0	0.9	1.5	1.0
Conformity markings					

Order Number

___ / 0 1 7 . ___ 0 0 . 2

	Size		UL-approved
	10		0 up to 300 V
	20		1 up to 500 V



Dimensions (mm)

Type 017.000.2

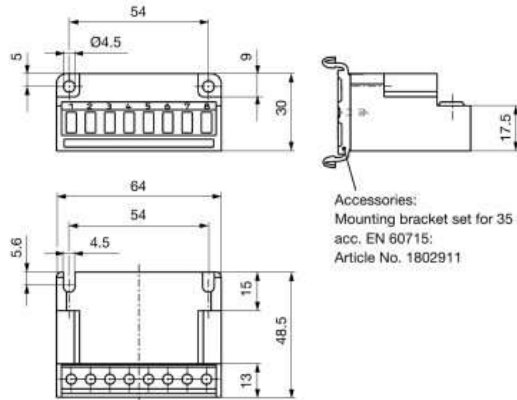

Accessories:
Mounting bracket set for 35 mm rail
acc. EN 60715:
Article No. 1802911

Type 017.100.2

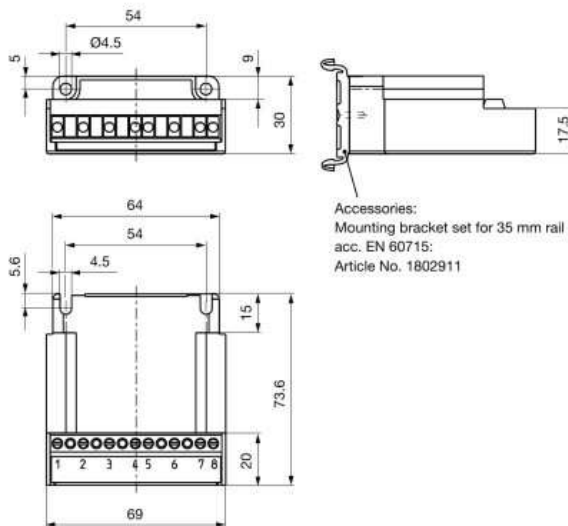

Accessories:
Mounting bracket set for 35 mm rail
acc. EN 60715:
Article No. 1802911

ROBA[®]-switch 24V Type 018.100.2



Application

ROBA[®]-switch 24V fast switching modules are used to operate DC consumers with overexcitation or power reduction, for example electromagnetic brakes and clutches (ROBA-stop[®], ROBA[®]-quick, ROBATIC[®]), electromagnets, electrovalves, etc.

Fast acting rectifier ROBA[®]-switch 24V 018.100.2

- Consumer operation with overexcitation or power reduction
- Integrated DC-side disconnection (shorter connection time t_c)
- Input voltage: 24 VDC
- Max. output current I_{RMS} : 5 A
- UL-approved



The ROBA[®]-switch 24V with integrated DC-side disconnection is not suitable for being the only safety disconnection in applications!



Function

The ROBA[®]-switch 24V units are used for an input voltage of 24 VDC. They can switch internally, meaning that the output voltage switches to holding voltage from the input voltage (=overexcitation voltage) via pulse-width modulation using 20 kHz. The overexcitation time can be adjusted via a DIP switch to 150 ms, 450 ms, 1 s, 1.5 s and 2.15 s. The holding voltage can be adjusted via a further DIP switch to 1/4, 1/3, 1/2 and 2/3 of the input voltage (equals 6 V, 8 V, 12 V and 16 V at an input voltage of 24 V).

Apart from this, the ROBA[®]-switch 24V has an integrated DC-side disconnection. In contrast to the usual DC-side disconnection, no further protective measures or external components are required. The DC-side disconnection is activated in standard mode and causes short switching times on the electromagnetic consumer. This can, however, be deactivated by installing a bridge between terminals 7 and 8 in order to produce soft brakings and quieter switching noises. However, this substantially lengthens the switching times (approx. 6 – 10x).

Electrical Connection (Terminals)

- 2 + 3 Input voltage, ground
- 4 Control input
- 5 – 7 Input voltage +24 VDC
- 8 + 9 Output voltage +
- 10 Output voltage -

Technical Data

Input voltage U_i	24 VDC + 20 % / - 10 % SELV/PELV
Output voltage U_o	Input voltage U_i
Output voltage U_H	1/4, 1/3, 1/2, 2/3 x U_i ± 20 %
Output current I_{RMS} at ≤ 45 °C	5.0 A
Output current I_{RMS} at max. 70 °C	2.5 A
Protection	IP00
Terminal nominal cross-section	1.5 mm ² (AWG 22-14)
Ambient temperature	-25 °C up to +70 °C
Storage temperature	-40 °C up to +70 °C

Dimensions (mm)

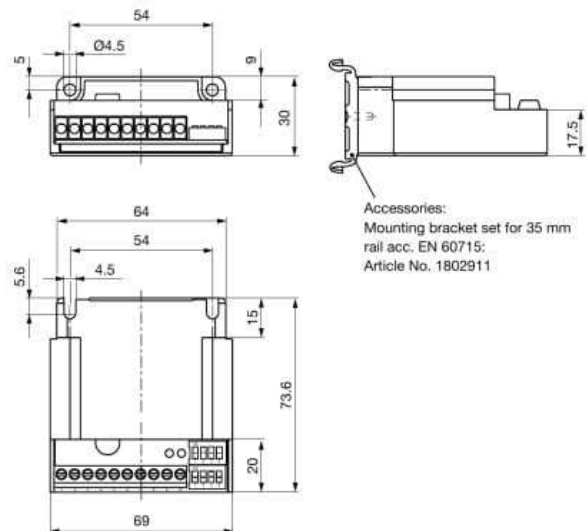

Order Number

— / 0 1 8 . 1 0 0 . 2



Size
1

Spark Quenching Unit Type 070.000.6



Application

Reduces spark production on the switching contacts occurring during DC-side switch-off of inductive loads.

- Voltage limitation according to VDE 0580 2000-07, Item 4.6.
- Reduction of EMC-disturbance by voltage rise limitation, suppression of switching sparks.
- Reduction of brake engagement times by a factor of 2 – 4 compared to freewheeling diodes.

Function

The spark quenching unit will absorb voltage peaks resulting from inductive load switching, which can cause damage to insulation and contacts. It limits these to 70 V and reduces the contact load. Switching products with a contact opening distance of > 3 mm are suitable for this purpose.



Electrical Connection (Terminals)

- | | |
|-------|------------------|
| 1 (+) | Input voltage |
| 2 (-) | Input voltage |
| 3 (-) | Coil |
| 4 (+) | Coil |
| 5 | Free nc terminal |
| 6 | Free nc terminal |

Dimensions (mm)

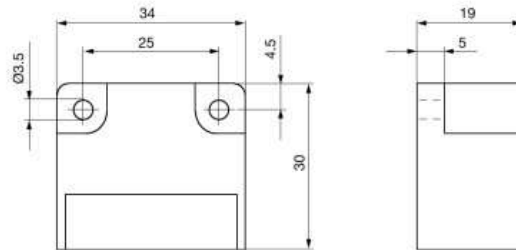

Technical Data

Input voltage	max. 300 VDC, max. 615 V _{peak} (rectified voltage 400 VAC, 50/60 Hz)
Switch-off energy	max. 9J/2 ms
Power dissipation	max. 0.1 Watt
Rated voltage nc terminals	250 V
Protection	IP65 components, IP20 terminals
Ambient temperature	-25 °C up to +85 °C
Storage temperature	-40 °C up to +85 °C
Max. conductor connection diameter	2.5 mm ² (AWG 26-12)
Max. terminal tightening torque	0.5 Nm

Accessories

Mounting bracket set for 35 mm rail acc. EN 60715:
Article-No. 1803201

Order Number

___ / 0 7 0 . 0 0 0 . 6



Size
1

The Safe Brake Control ROBA®-SBCplus Type 021.100.2



Technical Data

Electrical connection

Supply voltage logic 24VDC -15%/+20%
 Supply voltage power 24VDC or 48 VDC ±10%

Inputs:

Safe inputs 4 (Y10 – Y23)
 Standard inputs 4 (S35, S36, Y1, Y2)
 Monitoring times 30 ms ... 4000 ms

Outputs:

Supply voltage 24V 0.1A
 Acknowledgement outputs 24V 0.1A
 O3 fault message
 O4 Status circuit 1
 O5 Status circuit 2
 Test pulse outputs T0, T1, 24V, 0.1A
 Power outputs O1, O2
 Continuous operation 24V 2 x 4.5A max.
 Continuous operation 48V 2 x 2.25A max.
 Overexcitation 24V 2 x 6.5A max.
 Overexcitation 48V 2 x 3.25A max.
 Reduced voltages 6/8/12/16/24V ± 10%

Overexcitation times 100 ms ... 2500 ms
 Cycle frequency 4/min max.
 Ambient temperature 0 – 45 °C
 Protection IP20
 Installation into control cabinet IP54
 Dimensions 45x100x120mm
 Connection terminal 0.20 – 2.5mm², 24 – 12AWG
 Clamping terminals per connection 2

Certification:

Type examination tested by TÜV (German Technical Inspectorate), CE

Function:

- Safe control of 2 independent brakes
- Release monitoring via proximity switch or microswitch
- Fast or slow brake switch-off
- Safe monitoring of the switching times
- Parameterisation of the values
- Programmed and validated safety functions
- Safe signal output to the higher-level switching condition control

Application Example

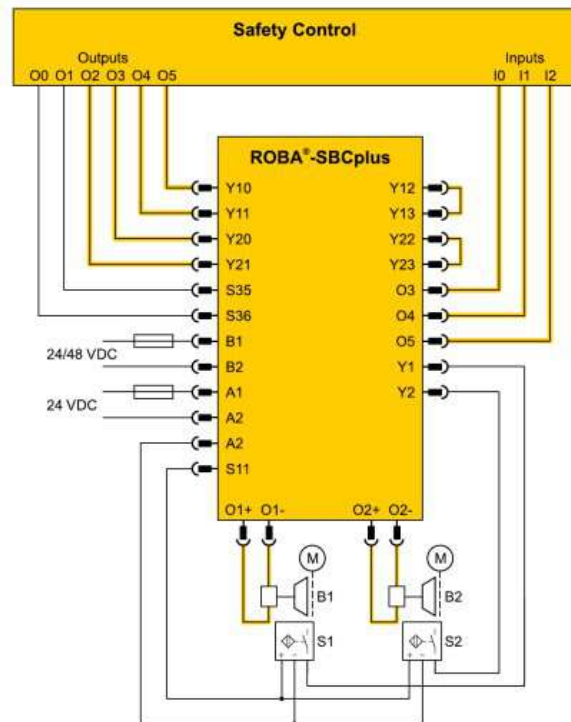

ROBA-stop®-silenzio® – Guidelines



Guidelines on the Declaration of Conformity: A conformity evaluation has been carried out for the product (electromagnetic safety brake) in terms of the EC low voltage directive 2006/95/EC. The Declaration of Conformity is laid out in writing in a separate document and can be requested if required.

Guidelines on the EMC Directive (2004/108/EC): The product cannot be operated independently according to the EMC directive. Due to their passive state, brakes are also non-critical equipment according to the EMC. Only after integration of the product into an overall system can this be evaluated in terms of the EMC. For electronic equipment, the evaluation has been verified for the individual product in laboratory conditions, but not in the overall system.

Guidelines on the Machinery Directive (2006/42/EC): The product is a component for installation into machines according to the Machinery Directive 2006/42/EC. The brakes can fulfil the specifications for safety-related applications in coordination with other elements. The type and scope of the required measures result from the machine risk analysis. The brake then becomes a machine component and the machine manufacturer assesses the conformity of the safety device to the directive. It is forbidden to start use of the product until you have ensured that the machine accords with the regulations stated in the directive.

Guidelines on the ATEX Directive: Without a conformity evaluation, this product is not suitable for use in areas where there is a high danger of explosion. For application of this product in areas where there is a high danger of explosion, it must be classified and marked according to directive 94/9/EC.

Safety Regulations

Brakes may generate several risks, among others:



During the risk assessment, the dangers involved must be evaluated and removed by taking appropriate protective measures.

To prevent injury or damage, only professionals and specialists are allowed to work on the devices. They must be familiar with the dimensioning, transport, installation, initial operation, maintenance and disposal according to the relevant standards and regulations.

Application Conditions



The catalogue values are guideline values which have been determined in test facilities. It may be necessary to carry out your own tests for the intended application.

When dimensioning the brakes, please remember that installation situations, braking torque fluctuations, permitted friction work, run-in behaviour and wear as well as general ambient conditions can all affect the given values. These factors should therefore be carefully assessed, and alignments made accordingly.

- Mounting dimensions and connection dimensions must be adjusted according to the size of the brake at the place of installation.
- The magnetic coils are designed for a relative duty cycle of 100%. However, a duty cycle > 60 % leads to higher temperatures, which cause premature ageing of the noise damping and therefore lead to an increase in switching noises.
- The braking torque is dependent on the run-in condition of the brake.
- The brakes are only designed for dry running. The torque is lost if the friction surfaces come into contact with oil, grease, water or similar substances or foreign bodies.
- Manufacturer-side corrosion protection of the metallic surfaces.
- The rotors may rust up and block in corrosive ambient conditions and/or after long periods of storage.

Ambient Temperature: -20 °C up to +40 °C

Earthing Connection

The brake is designed for Protection Class I. This protection covers not only the basic insulation, but also the connection of all conductive parts to the protective conductor (PE) on the fixed installation. Please carry out a standardised inspection of the protective conductor connections to all contactable metal parts!

Protection

(mechanical) IP10: Protection against large body surfaces and large foreign bodies > 50 mm in diameter. No protection against water.
(electrical) IP54: Dust-proof and protected against contact as well as against water spray from any direction.

Intended Use

mayr®-brakes have been developed, manufactured and tested in compliance with the VDE 0580 standard and in accordance with the EU Low Voltage Directive as electromagnetic components. During installation, operation and maintenance of the product, the requirements for the standard must be observed. *mayr*®-brakes are for use in machines and systems and must only be used in the situations for which they are ordered and confirmed. Using them for any other purpose is not allowed.

Guidelines for Electromagnetic Compatibility (EMC)

In accordance with the EMC directives 2004/108/EC, the individual components produce no emissions. However, functional components e.g. mains-side energisation of the brakes with rectifiers, phase demodulators, ROBA®-switch devices or similar controls can produce disturbance which lies above the allowed limit values.

For this reason it is important to read the Installation and Operational Instructions very carefully and to keep to the EMC Directives.

Regulations, Standards and Directives Used

VDE 0580	Electromagnetic devices and components, general specifications
2006/95/EC	Low voltage directive
95/16/EC	Elevator Directive
EN 81-1	Safety regulations for the construction and installation of elevators and small goods elevators
EN 81-1	(previously VGB 70) Safety regulations for theatre stage technical systems
EN 81-1	Industrial Control Equipment
EN 81-1	Industrial Control Equipment
EN 81-1	Safety of machinery - General principles for design - Risk assessment and risk reduction
EN 61000-6-4	Interference emission
EN 12016	Interference immunity (for elevators, escalators and moving walkways)
EN 60204-1	Electrical equipment of machines

Liability

- The information, guidelines and technical data in these documents were up to date at the time of printing. Demands on previously delivered brakes are not valid.
- Liability for damage and operational malfunctions will not be taken if:
 - the Installation and Operational Instructions are ignored or neglected.
 - the brakes are used inappropriately.
 - the brakes are modified.
 - the brakes are worked on unprofessionally.
 - the brakes are handled or operated incorrectly.

Guarantee

- The guarantee conditions correspond with the Chr. Mayr GmbH + Co. KG sales and delivery conditions.
- Mistakes or deficiencies are to be reported to *mayr*® at once!

Product Summary

Safety Clutches/Overload Clutches

- ❑ **EAS[®]-Compact[®]/EAS[®]-NC/EAS[®]-smartic[®]**
Positive locking and completely backlash-free torque limiting clutches
- ❑ **EAS[®]-reverse**
Reversing, re-engaging torque limiter
- ❑ **EAS[®]-element clutch/EAS[®]-elements**
Load-disconnecting protection against high torques
- ❑ **EAS[®]-axial**
Exact limitation of tensile and compressive forces
- ❑ **EAS[®]-Sp/EAS[®]-Sm/EAS[®]-Zr**
Load-disconnecting torque limiting clutches with switching function
- ❑ **ROBA[®]-slip hub**
Load-holding, frictionally locked torque limiting clutches
- ❑ **ROBA[®]-contitorque**
Magnetic continuous slip clutches
- ❑ **EAS[®]-HSC/EAS[®]-HSE**
High-speed safety clutches for high-speed applications



Shaft Couplings

- ❑ **smartflex[®]/primeflex[®]**
Perfect precision couplings for servo and stepping motors
- ❑ **ROBA[®]-ES**
Backlash-free and damping for vibration-sensitive drives
- ❑ **ROBA[®]-DS/ROBA[®]-D**
Backlash-free, torsionally rigid all-steel couplings
- ❑ **ROBA[®]-DSM**
Cost-effective torque-measuring couplings



Electromagnetic Brakes/Clutches

- ❑ **ROBA-stop[®] standard**
Multifunctional all-round safety brakes
- ❑ **ROBA-stop[®]-M motor brakes**
Robust, cost-effective motor brakes
- ❑ **ROBA-stop[®]-S**
Water-proof, robust monoblock brakes
- ❑ **ROBA[®]-duplostop[®]/ROBA[®]-twinstop[®]/ROBA-stop[®]-silenzio[®]**
Doubly safe elevator brakes
- ❑ **ROBA[®]-diskstop[®]**
Compact, very quiet disk brakes
- ❑ **ROBA[®]-topstop[®]**
Brake systems for gravity loaded axes
- ❑ **ROBA[®]-linearstop**
Backlash-free brake systems for linear motor axes
- ❑ **ROBA[®]-guidestop**
Backlash-free holding brake for profield rail guides
- ❑ **ROBATIC[®]/ROBA[®]-quick/ROBA[®]-takt**
Electromagnetic clutches and brakes, clutch brake units



DC Drives

- ❑ **tendo[®]-PM**
Permanent magnet-excited DC motors



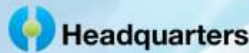

Chr. Mayr GmbH + Co. KG
Eichenstraße 1, D-87665 Mauerstetten
Tel.: +49 83 41/8 04-0, Fax: +49 83 41/80 44 21
www.mayr.com, E-Mail: info@mayr.com



Service Germany/Austria

Baden-Württemberg

Esslinger Straße 7
 70771 Leinfelden-Echterdingen
 Tel.: 07 11/45 96 01 0
 Fax: 07 11/45 96 01 10

Bavaria

Industriestraße 51
 82194 Gröbenzell
 Tel.: 0 81 42/50 19 80-7

Chemnitz

Bornaer Straße 205
 09114 Chemnitz
 Tel.: 03 71/4 74 18 96
 Fax: 03 71/4 74 18 95

Franken

Unterer Markt 9
 91217 Hersbruck
 Tel.: 0 91 51/81 48 64
 Fax: 0 91 51/81 62 45

Kamen

Herbert-Wehner-Straße 2
 59174 Kamen
 Tel.: 0 23 07/24 26 79
 Fax: 0 23 07/24 26 74

North

Schiefer Brink 8
 32699 Extertal
 Tel.: 0 57 54/9 20 77
 Fax: 0 57 54/9 20 78

Rhine-Main

Kreuzgrundweg 3a
 36100 Petersberg
 Tel.: 06 61/96 21 02 15

Austria

Pummerinplatz 1, TIZ I, A27
 4490 St. Florian, Austria
 Tel.: 0 72 24/2 20 81-12
 Fax: 0 72 24/2 20 81 89

Branch office

China

Mayr Zhangjiagang
 Power Transmission Co., Ltd.
 Fuxin Road No.7, Yangshe Town
 215637 Zhangjiagang
 Tel.: 05 12/58 91-75 67
 Fax: 05 12/58 91-75 66
 info@mayr-ptc.cn

Great Britain

Mayr Transmissions Ltd.
 Valley Road, Business Park
 Keighley, BD21 4LZ
 West Yorkshire
 Tel.: 0 15 35/66 39 00
 Fax: 0 15 35/66 32 61
 sales@mayr.co.uk

France

Mayr France S.A.S.
 Z.A.L. du Minopole
 Rue Nungesser et Coli
 62160 Bully-Les-Mines
 Tel.: 03.21.72.91.91
 Fax: 03.21.29.71.77
 contact@mayr.fr

Italy

Mayr Italia S.r.l.
 Viale Veneto, 3
 35020 Saonara (PD)
 Tel.: 0498/79 10 20
 Fax: 0498/79 10 22
 info@mayr-italia.it

Singapore

Mayr Transmission (S) PTE Ltd.
 No. 8 Boon Lay Way Unit 03-06,
 TradeHub 21
 Singapore 609964
 Tel.: 00 65/65 60 12 30
 Fax: 00 65/65 60 10 00
 info@mayr.com.sg

Switzerland

Mayr Kupplungen AG
 Tobeläckerstraße 11
 8212 Neuhausen am Rheinfall
 Tel.: 0 52/6 74 08 70
 Fax: 0 52/6 74 08 75
 info@mayr.ch

USA

Mayr Corporation
 10 Industrial Avenue
 Mahwah
 NJ 07430
 Tel.: 2 01/4 45-72 10
 Fax: 2 01/4 45-80 19
 info@mayrcorp.com

Turkey

Representative Office Turkey
 Kucukbakkalkoy Mah.
 Brandium Residence R2
 Blok D:254
 34750 Atasehir - Istanbul, Turkey
 Tel.: 02 16/2 32 20 44
 Fax: 02 16/5 04 41 72
 info@mayr.com.tr

Representatives

Australia

Drive Systems Pty Ltd.
 12 Sommersby Court
 Lysterfield, Victoria 3156
 Australien
 Tel.: 0 3/97 59 71 00
 dean.hansen@drivesystems.com.au

India

National Engineering
 Company (NENCO)
 J-225, M.I.D.C.
 Bhosari Pune 411026
 Tel.: 0 20/27 13 00 29
 Fax: 0 20/27 13 02 29
 nenco@nenco.org

Japan

MATSUI Corporation
 2-4-7 Azabudai
 Minato-ku
 Tokyo 106-8641
 Tel.: 03/35 86-41 41
 Fax: 03/32 24 24 10
 k.goto@matsui-corp.co.jp

Netherlands

Groneman BV
 Amarilstraat 11
 7554 TV Hengelo OV
 Tel.: 074/2 55 11 40
 Fax: 074/2 55 11 09
 aandrijftechnik@groneman.nl

Poland

Wamex Sp. z o.o.
 ul. Pozaryskiego, 28
 04-703 Warszawa
 Tel.: 0 22/6 15 90 80
 Fax: 0 22/8 15 61 80
 wamex@wamex.com.pl

South Korea

Mayr Korea Co. Ltd.
 15, Yeondeok-ro 9beon-gil
 Seongsan-gu
 51571 Changwon-si
 Gyeongsangnam-do, Korea
 Tel.: 0 55/2 62-40 24
 Fax: 0 55/2 62-40 25
 info@mayrkorea.com

Taiwan

German Tech Auto Co., Ltd.
 No. 28, Fenggong Zhong Road,
 Shengang Dist.,
 Taichung City 429, Taiwan R.O.C.
 Tel.: 04/25 15 05 66
 Fax: 04/25 15 24 13
 abby@zfgta.com.tw

Czech Republic

BMC - TECH s.r.o.
 Hviezdoslavova 29 b
 62700 Brno
 Tel.: 05/45 22 60 47
 Fax: 05/45 22 60 48
 info@bmc-tech.cz

More representatives:

Belgium, Brazil, Canada, Colombia, Croatia, Denmark, Finland, Greece, Hongkong, Hungary, Indonesia, Israel, Luxembourg, Malaysia, Mexico, New Zealand, Norway, Philippines, Portugal, Romania, Russia, Slovakia, Slovenia, South Africa, Spain, Sweden, Thailand

You can find the complete address for the representative responsible for your area under www.mayr.com in the internet.