



your reliable partner



ROBA[®]-ES

K.940.V18.EN

www.mayr.com

We safeguard the movements of this world



The Christian Mayr mill-construction business – founded in 1897.



Communications Centre mayr.com – opened in 2018.

Specialists in power transmission for more than a century

mayr[®] power transmission is one of the most traditional and yet most innovative German companies in the field of power transmission. From modest beginnings in the year 1897, the family enterprise from the Allgäu region has developed into the world market leader. Today, 700 employees work at the headquarters in Mauerstetten; more than 1200 employees work for the company worldwide.

An unsurpassed standard product range

mayr[®] power transmission offers a wide variety of torque limiters, safety brakes, backlash-free shaft misalignment compensation couplings and high-quality DC drives. Regarding customer-specific requirements, too, the company possesses the expertise to develop customized and economical solutions. This is why numerous renowned machine manufacturers trust in holistic solutions by *mayr*[®] power transmission.

Represented worldwide

With eight subsidiaries in Germany, sales offices in the USA, France, Great Britain, Italy, Singapore and Switzerland as well as 36 additional country representatives, *mayr*[®] is available in all important industrial areas, guaranteeing optimum customer service around the globe.



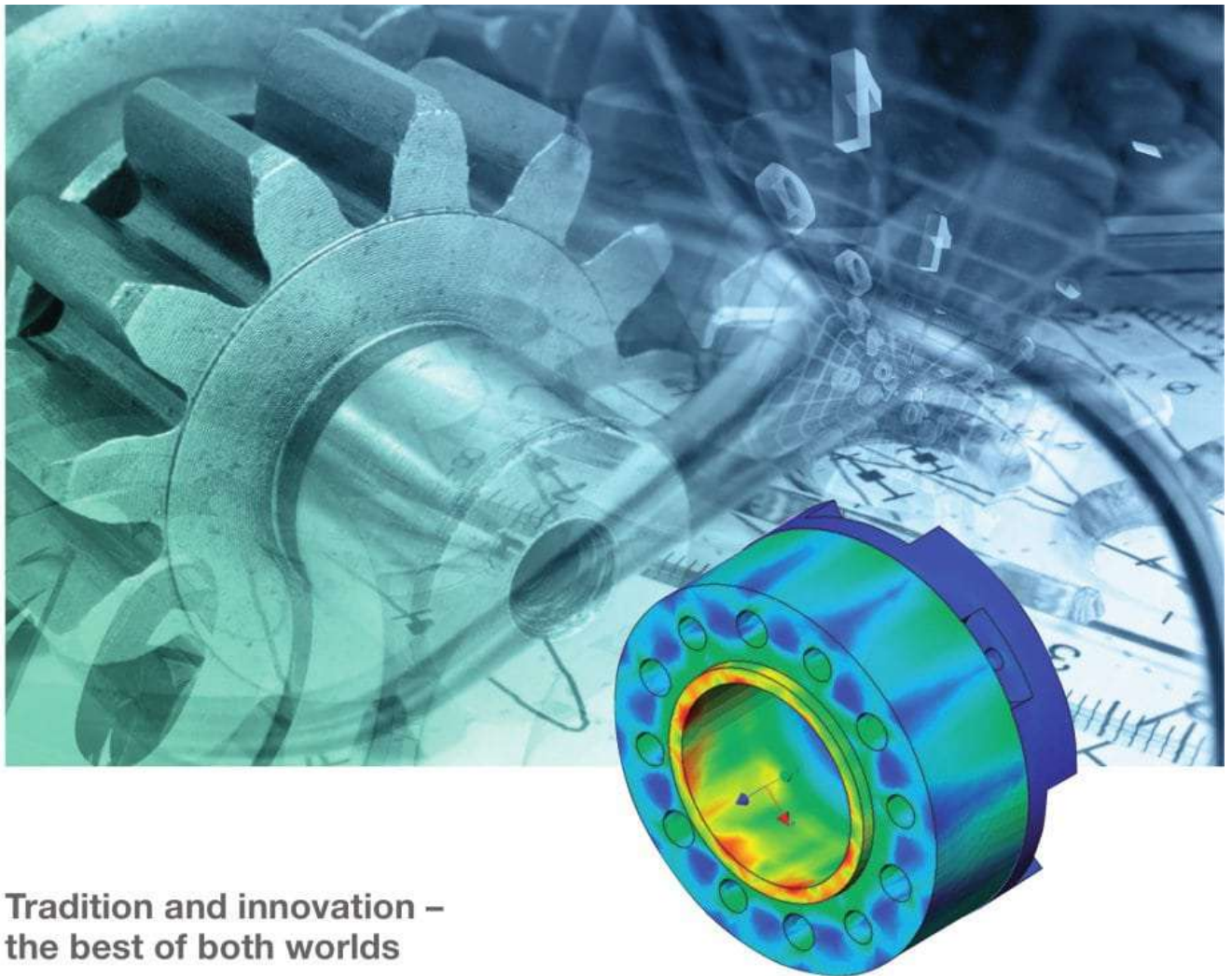

Tradition and innovation – the best of both worlds

Tradition and innovation do not contradict each other - on the contrary. They are the two supporting pillars which have guaranteed stability and reliability for generations. Long-term stability, independence as well as a good reputation and satisfied customers are important values for a family enterprise rich in tradition.

Therefore, we place emphasis on:

- Tested product quality,
- Optimum customer service,
- Comprehensive know-how,
- Global presence,
- Successful innovations and
- Effective cost management.

By pursuing our own objective of always offering our customers the technologically most advanced and most economical solution, we have been able to gain the trust of many leading industrial companies from all branches and from all over the world as a reliable partner.

Place your trust in our know-how and our more than 50 years of experience in the areas of torque limiters, safety brakes and shaft couplings.

ROBA[®]-ES

Backlash-free elastomer coupling

- Vibration damping
- Damping behaviour can be selected through elastomeric elements in different Shore hardnesses
- Backlash-free torque transmission through pre-tensioned elastomeric element
- Compensation of shaft misalignments
- Plug-in connection, therefore suitable for blind assembly
- Maintenance-free, media-resistant, temperature-stable
- Torsionally flexible on a small scale, but two to four times more rigid than toothed belt drives.



ROBA[®]-ES Elastomeric Elements

The elastomeric elements are the central element of the ROBA[®]-ES-coupling. They define the application field as well as the shaft connection behavior via the permitted torque, the rigidity, the damping and the misalignment values.

By using a unique polyurethane material and a special injection procedure, it is possible to achieve a high dimensional accuracy and evenness in the teeth of the elastomeric element.

The elastomeric elements are available in different shore hardnesses. The teeth of the elastomeric element are chamfered at the sides. This makes blind assembly easier.

The ambient temperatures present during operation have a considerable effect on the dimensioning of a ROBA[®]-ES-coupling (see Dimensioning page 22).

Dimensioning

The characteristics of ROBA[®]-ES couplings can be greatly varied by using different elastomeric elements. Due to different damping characteristics and the non-linear rigidity of the elastomer, this element also offers more parameters than the steel shaft connection, which should be taken into account on selection.

We therefore recommend careful, thorough coupling dimensioning (see Dimensioning page 22).

Agent Resistance

The elastomeric elements are very resistant against

- pure mineral oils (lubricating oils)
- and anhydrous greases.

They have a similar resistance against fuels such as

- regular-grade petroleum
- diesel oil
- kerosene.

Damage may occur after longer exposure to

- alcohols or
- aromatic fuels (super/four star petrol).

The elastomeric element material used is resistant to hydrolysis. In contrast to other polyurethane materials, water (including sea water) causes, even after years of exposure, no particular changes to the mechanical characteristics. Hot water, however, reduces the mechanical strength.



ROBA[®]-ES couplings are also available in ATEX design according to the directive 2014/34/EU.

ROBA®-ES Contents

Designs

ROBA®-ES with key hubs

- Single-jointed coupling
- Double-jointed coupling short
- Double-jointed coupling with sleeve

ROBA®-ES couplings are delivered as un-bored hub design (further processing to be carried out customer-side) or with a finish bore and keyway JS9 (DIN 6885/1). An adjusting screw is located in the hub for axial securement. Up to Size 38, the hubs are made of aluminium. From Size 42, they are made of steel.

Conventional bores can be delivered from stock.



Page 8

ROBA®-ES with clamping hubs

- Single-jointed coupling
- Double-jointed coupling short
- Double-jointed coupling with sleeve

ROBA®-ES couplings with clamping hubs are conceived for fast and safe installation or de-installation. They have no keyway. The tightening torque (T_n) on the clamping screws must be maintained in order to ensure reliable, frictionally-locking torque transmission.

Please observe the maximum permitted torques (Page 28).

Up to Size 38, the hubs are made of aluminium. From Size 42, they are made of steel.

The clamping hub can be designed with an additional keyway on request.



Page 10

ROBA®-ES with clamping hubs Compact

- Single-jointed coupling
- Double-jointed coupling short
- Double-jointed coupling with sleeve

ROBA®-ES couplings with clamping hubs are conceived for fast and safe installation or de-installation. They have no keyway. The tightening torque (T_n) on the clamping screws must be maintained in order to ensure reliable, frictionally-locking torque transmission.

Please observe the maximum permitted torques (Page 28).

The hubs are made of aluminium. The clamping hub can be designed with an additional keyway on request.

Due to the compact construction of the short clamping hubs, the couplings can be used in constricted installation conditions



Page 12

ROBA®-ES with split clamping hubs

- Single-jointed coupling
- Double-jointed coupling short
- Double-jointed coupling with sleeve

ROBA®-ES couplings with split clamping hubs are conceived for fast and safe installation or de-installation. Due to the orientation of the half-shells in the same direction, radial assembly/disassembly of the coupling is possible at stationary shaft ends. The tightening torque (T_n) on the clamping screws must be maintained in order to ensure reliable, frictionally-locking torque transmission.

Please observe the maximum permitted torques (page 29).

Up to Size 38, the hubs are made of aluminium. From Size 42, they are made of steel. The split clamping hub can be designed with an additional keyway on request.



Page 14

ROBA[®]-ES with aluminium shrink disk hubs

- Single-jointed coupling
- Double-jointed coupling short

On this design, the hub body is made of aluminium and the ring of phosphated, annealed steel. The design is constructionally identical to the P-design (page 19). The symmetry, the absence of keyways and radial bores produces an optimum shaft run-out. Therefore, much higher speeds are possible compared to the other hub designs (please observe Diagram 1 "Balancing the shrink disk hub", page 31).

The torque is transmitted via frictional locking onto the shaft.
Please observe the maximum permitted torques (page 27).



Page 16

ROBA[®]-ES with steel shrink disk hubs

- Single-jointed coupling
- Double-jointed coupling short

On this design, the hub body is made of steel (oiled) and the ring of phosphated, annealed steel. This design is available in a standard variant and a variant according to DIN 69002. The DIN variant has an elastomeric element with a central, standardised bore and standardised bore diameters in the hubs. The DIN variant is conceived for use in short bore spindles and multi-spindle heads. Because of the steel hubs, this DIN design combines robustness with precision. This design should be selected in preference to others, in particular on applications with heavily pulsating or alternating loads.

Please observe the maximum permitted torques (page 27).



Page 18

ROBA[®]-ES with expansion hub and clamping hub

- Single-jointed coupling

ROBA[®]-ES couplings with an expansion hub have been designed for frictionally-locking torque transmission onto hollow shafts. The expansion hubs are combined with clamping hubs on the opposite side as a standard measure. Other combinations with other hubs are conceivable.

The stated diameters of the expansion hubs are preferred dimensions.

Other diameters can be requested at *mayr*[®] power transmission.

Please observe the maximum permitted torques (page 29).



Page 20

Coupling Dimensioning Page 22 ▷

Technical Explanations Page 24 ▷

Size	Torques									
	Elastomeric element hardness									
	80 Sh A (blue)		92 Sh A (yellow)		98 Sh A (red)		64 Sh D (green)		72 Sh D (grey)	
	T_{KN} [Nm]	T_{Kmax} [Nm]	T_{KN} [Nm]	T_{Kmax} [Nm]	T_{KN} [Nm]	T_{Kmax} [Nm]	T_{KN} [Nm]	T_{Kmax} [Nm]	T_{KN} [Nm]	T_{Kmax} [Nm]
14	4	8	8	16	13	26	16	32	-	-
19	5	10	10	20	17	34	21	42	27	54
24	17	34	35	70	60	120	75	150	95	190
28	46	92	95	190	160	320	200	400	260	520
38	95	190	190	380	325	650	405	810	525	1050
42	125	250	265	530	450	900	560	1120	725	1450
48	150	300	310	620	525	1050	655	1310	850	1700
55	200	400	410	820	685	1370	825	1650	-	-
65	450	900	900	1800	1040	2080	1250	2500	-	-

Technical Explanations (transmittable torques) Page 27 ▷

ROBA®-ES elastomer couplings Type 94.

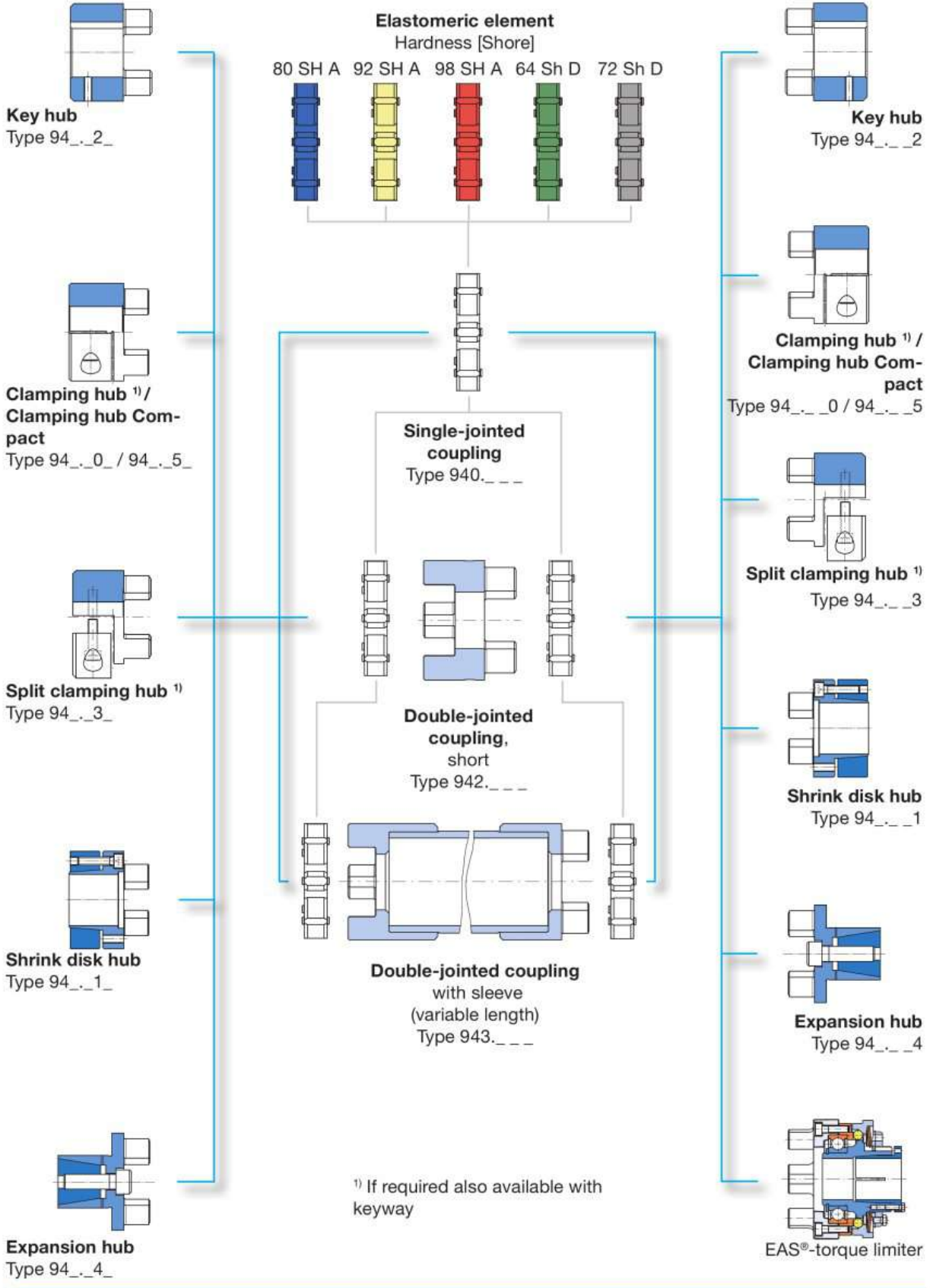

ROBA®-ES with key hubs

Sizes 14 to 65

Single-jointed coupling / Type 940. 22.

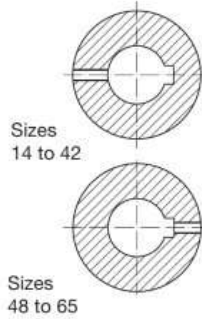
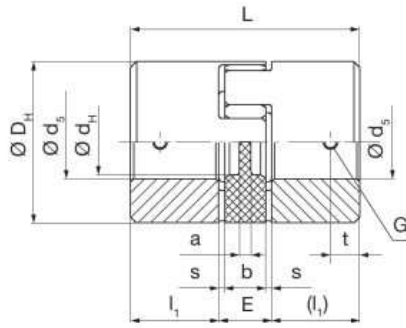

The adjusting screw is offset by 180° to the keyway on Sizes 14 to 42 (see Fig. above).



Technical Data and Main Dimensions			Size									
			14	19	24	28	38	42	48	55	65	
Minimum hub bore ^{1) 2)}	$d_{s, \min}^{H7}$	[mm]	6	6	8	10	12	14	20	20	38	
Maximum hub bore ^{1) 2)}	$d_{s, \max}^{H7}$	[mm]	15	24	28	38	45	55	60	70	80	
Maximum speed ^{3) 4)}	n_{\max}	[rpm]	19000	14000	10600	8500	7100	6000	5600	5000	4600	

Mass moments of inertia J [10⁻³ kgm²] ^{5) 6)}

	Size	14	19	24	28	38	42	48	55	65
Elastomeric element		0.0005	0.0012	0.0067	0.0154	0.042	0.09	0.143	0.248	0.474
Key hub		0.0026	0.0175	0.0781	0.169	0.498	3.093	5.173	10.096	18.524
Single-jointed coupling short		0.0057	0.0362	0.1629	0.3534	1.038	6.276	10.489	20.44	37.522
Sleeve with H _s = 1000 mm		0.075	0.27	0.74	1.33	2.42	14.33	29.7	48.94	71.43
Sleeve with 1000 mm tube		0.071	0.236	0.676	1.202	1.917	10.676	24.89	41.167	54.082

Weights [kg] ^{5) 6)}

	Size	14	19	24	28	38	42	48	55	65
Elastomeric element		0.0048	0.007	0.019	0.037	0.054	0.081	0.104	0.149	0.216
Key hub		0.018	0.064	0.161	0.236	0.47	2.03	2.792	4.136	5.95
Single-jointed coupling short		0.041	0.135	0.341	0.509	0.994	4.141	5.688	8.421	12.116
Sleeve with H _s = 1000 mm		0.595	1.036	1.323	1.631	2.101	9.429	15.764	18.009	21.351
Sleeve with 1000 mm tube		0.574	0.86	1.22	1.477	1.705	7.383	13.561	15.193	16.622

Dimensions	Size									
	14	19	24	28	38	42	48	55	65	
a	2	4	4	5	5	5	5	9	8	
b	10	12	14	15	18	20	21	22	26	
D _H	30	40	55	65	80	95	105	120	135	
d _H	10.5	18	27	30	38	46	51	60	68	
E	13	16	18	20	24	26	28	30	35	
G	M4	M5	M5	M6	M8	M8	M8	M10	M10	
L	35	66	78	90	114	126	140	160	185	
L ₂	56	92	112	128	158	174	192	218	252	
L ₃	dependent on H _s									
l ₁	11	25	30	35	45	50	56	65	75	
l ₂	34	42	52	58	68	74	80	88	102	
H _{s, min}	68	87	101	115	143	162	178	200	230	
H _{s, max}	2000	2000	2000	2000	2000	2000	2000	3000	3000	
s	1.5	2.0	2.0	2.5	3.0	3.0	3.5	4.0	4.5	
t	5	10	10	15	15	20	25	20	20	

We reserve the right to make dimensional and constructional alterations.

Stock program	Size					
	Bore	14	19	24	28	38
Ø6						
Ø8	x					
Ø9						
Ø10	x	x				
Ø11	x					
Ø12	x	x				
Ø14	x	x	x			
Ø15		x	x			
Ø16		x	x			
Ø17						
Ø18		x	x			
Ø19		x	x	x		
Ø20		x	x	x	x	
Ø22				x		
Ø24				x	x	
Ø25				x	x	x
Ø28				x		
Ø30				x	x	
Ø32				x	x	
Ø35					x	
Ø38						x

ROBA[®]-ES with key hubs

Sizes 14 to 65

Double-jointed coupling short / Type 942. 22.

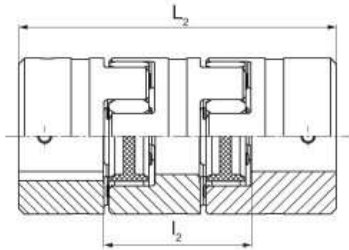

Double-jointed coupling with sleeve / Type 943. 22.

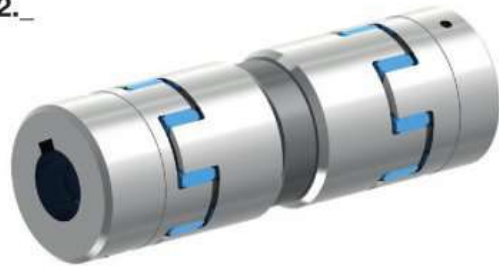
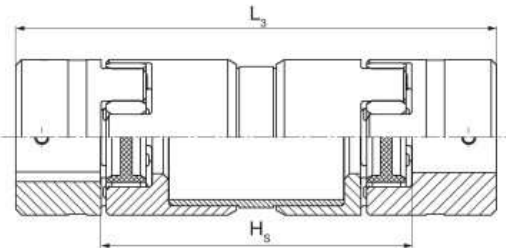

Order Number

		0 Single-jointed coupling 2 Double-jointed coupling short 3 Double-jointed coupling with sleeve					Sleeve length H_s [mm]	
		▼					▼	
		9 4 . 2 2 . / / / / /						
		▲					▲	
Size 14 to 65 ⁷⁾	Elastomeric element hard- ness	98 Sh A (red) 92 Sh A (yellow) 80 Sh A (blue) 64 Sh D (green) 72 Sh D (grey)	0 1 5 6 7	Aluminium design up to Size 38 Steel design from Size 42	A F	Bore \varnothing d_s^{H7} (see Table)	Bore \varnothing d_s^{H7} (see Table)	Operating speed n_s [rpm] for sleeve

Example: 42 / 940.022.F / $\varnothing d_s$ 30 / $\varnothing d_s$ 30

- 1) Recommended hub / shaft tolerance: H7 / k6
- 2) In order to dimension the shaft-hub connection, the calculation procedure acc. DIN 6892 is to be applied. For the calculation, please take the yield point $R_p 0.2 = 200 \text{ N/mm}^2$ for aluminium and the yield strength $R_e = 350 \text{ N/mm}^2$ for steel.
- 3) Also applicable for double-jointed design
- 4) Not valid for designs with sleeve (see diagram: "Permitted speeds for sleeve" on page 26)
- 5) Mass moments of inertia and weights are valid for one elastomeric element
- 6) Mass moments of inertia and weights are valid for maximum bore
- 7) Further Sizes available on request

ROBA®-ES with clamping hubs

Sizes 14 to 65

Single-jointed coupling / Type 940._ 00._

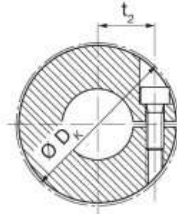
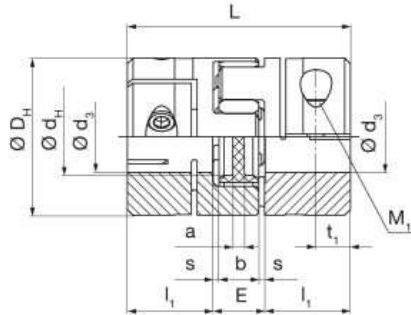

Technical Data and Main Dimensions			Size									
			14	19	24	28	38	42	48	55	65	
Minimum hub bore ^{1) 2)}	$d_s^{F7}_{min}$	[mm]	6	10	15	19	20	28	35	40	45	
Maximum hub bore ^{1) 2)}	$d_s^{F7}_{max}$	[mm]	15	20	28	35	45	50	55	70	80	
Maximum speed ^{3) 4)}	n_{max}	[rpm]	12600	9300	7000	5600	4700	4000	3700	3300	3000	
Tightening torque clamping screws	T_A	[Nm]	1.4	10	10	25	25	70	120	120	200	

Mass moments of inertia J [10⁻³ kgm²] ^{5) 6)}

	Size	14	19	24	28	38	42	48	55	65
Elastomeric element		0.0005	0.0012	0.0067	0.0154	0.042	0.09	0.143	0.248	0.474
Clamping hub		0.0028	0.0193	0.076	0.168	0.481	3.104	5.176	9.742	17.985
Single-jointed coupling short		0.0061	0.0398	0.1587	0.3514	1.004	6.298	10.495	19.732	36.444
Sleeve with H _s = 1000 mm		0.075	0.27	0.74	1.33	2.42	14.33	29.7	48.94	71.43
Sleeve with 1000 mm tube		0.071	0.236	0.676	1.202	1.917	10.676	24.89	41.167	54.082

Weights [kg] ^{5) 6)}

	Size	14	19	24	28	38	42	48	55	65
Elastomeric element		0.0048	0.007	0.019	0.037	0.054	0.081	0.104	0.149	0.216
Clamping hub		0.02	0.077	0.159	0.245	0.456	2.134	2.922	4.021	5.818
Single-jointed coupling short		0.0448	0.161	0.337	0.527	0.966	4.349	5.948	8.191	11.852
Sleeve with H _s = 1000 mm		0.595	1.036	1.323	1.631	2.101	9.429	15.764	18.009	21.351
Sleeve with 1000 mm tube		0.574	0.86	1.22	1.477	1.705	7.383	13.561	15.193	16.622

Dimensions	Size									
	14	19	24	28	38	42	48	55	65	
a	2	3	4	5	6	6	5	9	8	
b	10	12	14	15	18	20	21	22	26	
D _H	30	40	55	65	80	95	105	120	135	
D _K	32.2	47	56.4	72.6	83.3	98.8	108	122	139	
d _H	10.5	18	27	30	38.5	46	51	60	68	
E	13	16	18	20	24	26	28	30	35	
L	35	66	78	90	114	126	140	160	185	
L ₂	56	92	112	128	158	174	192	218	252	
L ₃	dependent on H _s									
l ₁	11	25	30	35	45	50	56	65	75	
l ₂	34	42	52	58	68	74	80	88	102	
H _{s,min}	68	87	101	115	143	162	178	200	230	
H _{s,max}	2000	2000	2000	2000	2000	2000	2000	3000	3000	
M ₁	M3	M6	M6	M8	M8	M10	M12	M12	M14	
s	1.5	2	2	2.5	3	3	3.5	4	4.5	
t ₁	5.5	12	12	13.5	20	20	21	26	27.5	
t ₂	11	14	20	24	30	34	36	45	52	

We reserve the right to make dimensional and constructional alterations.

Stock program	Size					
	Bore	14	19	24	28	38
Ø6						
Ø7						
Ø8	x					
Ø9	x					
Ø10	x	x				
Ø11	x	x				
Ø12	x	x				
Ø14	x	x				
Ø15	x	x	x			
Ø16		x	x			
Ø17						
Ø18			x			
Ø19		x	x	x		
Ø20		x	x	x		
Ø22			x	x		
Ø24			x	x		
Ø25			x	x	x	
Ø28			x	x		
Ø30				x		
Ø32				x	x	
Ø35					x	
Ø38						x
Ø40						x

ROBA[®]-ES with clamping hubs

Sizes 14 to 65

Double-jointed coupling short / Type 942._00._

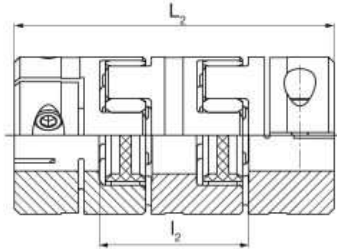

Double-jointed coupling with sleeve / Type 943._00._

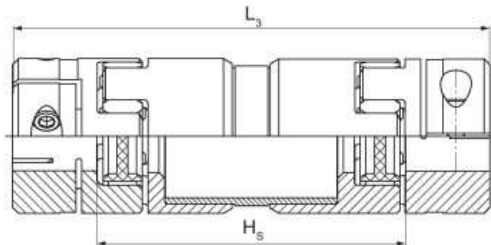

Order Number

		0 Single-jointed coupling 2 Double-jointed coupling short 3 Double-jointed coupling with sleeve					Sleeve length H_s [mm]		
		▼					▼		
_ / 9 4 _ . _ 0 0 . _ / _ / _ / _ / _									
▲		▲		▲		▲		▲	
Size 14 to 65 ⁷⁾	Elastomeric element hardness	98 Sh A (red) 92 Sh A (yellow) 80 Sh A (blue) 64 Sh D (green) 72 Sh D (grey)	0 1 5 6 7	Aluminium design up to Size 38 Steel design from Size 42	A F	Bore $\varnothing d_3^{F7}$ (see Table)	Bore $\varnothing d_3^{F7}$ (see Table)	Operating speed n_s [rpm] for sleeve	

Example: 42 / 940.000.F / $\varnothing d_3$ 30 / $\varnothing d_3$ 30

- 1) Recommended hub / shaft tolerance: F7 / k6
- 2) Transmittable torques dependent on bore, see page 28.
- 3) Also applicable for double-jointed design
- 4) Not valid for designs with sleeve (see diagram: "Permitted speeds for sleeve" on page 26)
- 5) Mass moments of inertia and weights are valid for one elastomeric element
- 6) Mass moments of inertia and weights are valid for maximum bore
- 7) Further Sizes available on request

ROBA®-ES with clamping hubs Compact

Sizes 14 to 38

Single-jointed coupling / Type 940._ 55._

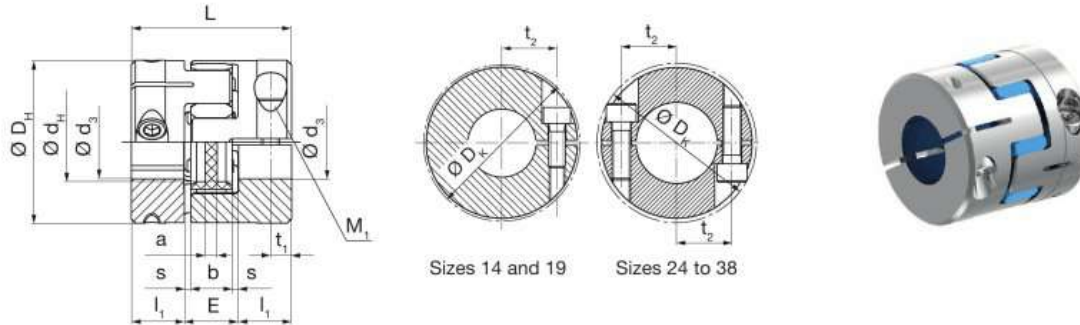

Technical Data and Main Dimensions			Size				
			14	19	24	28	38
Minimum hub bore ^{1) 2)}	$d_s^{F7}_{min}$	[mm]	5	8	10	14	15
Maximum hub bore ^{1) 2)}	$d_s^{F7}_{max}$	[mm]	12	20	32	35	45
Maximum speed ^{3) 4)}	n_{max}	[rpm]	12600	9300	7000	5600	4700
Tightening torque clamping screws	T_A	[Nm]	3	10	10	25	48

Mass moments of inertia J [10⁻³ kgm²] ^{5) 6)}

	Size	14	19	24	28	38
Elastomeric element		0.0005	0.0012	0.0067	0.0154	0.042
Clamping hub		0.0025	0.0139	0.0493	0.1174	0.328
Single-jointed coupling short		0.0055	0.029	0.1053	0.2502	0.698
Sleeve with H _s = 1000 mm		0.075	0.27	0.74	1.33	2.42
Sleeve with 1000 mm tube		0.071	0.236	0.676	1.202	1.917

Weights [kg] ^{5) 6)}

	Size	14	19	24	28	38
Elastomeric element		0.0048	0.007	0.019	0.037	0.054
Clamping hub		0.0192	0.055	0.098	0.173	0.311
Single-jointed coupling short		0.0432	0.117	0.215	0.383	0.676
Sleeve with H _s = 1000 mm		0.595	1.036	1.323	1.631	2.101
Sleeve with 1000 mm tube		0.574	0.86	1.22	1.477	1.705

Dimensions	Size				
	14	19	24	28	38
a	2	3	4	5	6
b	10	12	14	15	18
D _H	30	40	55	65	80
D _K	31	46	58	69.5	86
d _H	10.5	18	27	30	38.5
E	13	16	18	20	24
L	32	50	54	62	76
L ₂	53	76	88	100	120
L ₃	dependent on H _s				
l ₁	9.5	17	18	21	26
l ₂	34	42	52	58	68
H _{s,min}	68	87	101	115	143
H _{s,max}	2000	2000	2000	2000	2000
M ₁	M4	M6	2xM6	2xM8	2xM10
s	1.5	2	2	2.5	3
t ₁	5	8	7	9	10
t ₂	9.6	14	20	23.8	30.5

We reserve the right to make dimensional and constructional alterations.

Stock program	Size					
	Bore	14	19	24	28	38
Ø6						
Ø7						
Ø8	x					
Ø9	x					
Ø10	x	x				
Ø11	x	x				
Ø12	x	x				
Ø14		x				
Ø15		x	x			
Ø16		x	x			
Ø17						
Ø18			x			
Ø19			x	x		
Ø20			x	x		
Ø22			x	x		
Ø24			x	x		
Ø25			x	x	x	
Ø28			x	x		
Ø30				x		
Ø32				x	x	
Ø35					x	
Ø38					x	
Ø40						x

ROBA[®]-ES with clamping hubs Compact

Sizes 14 to 38

Double-jointed coupling short / Type 942._55._

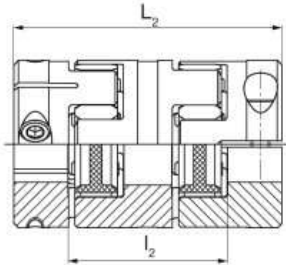

Double-jointed coupling with sleeve / Type 943._55._

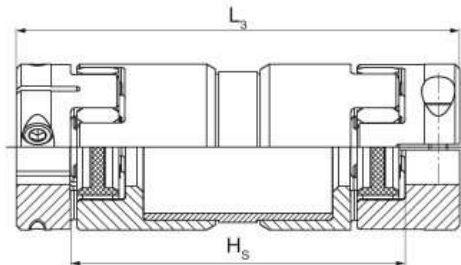

Order Number

		0 Single-jointed coupling 2 Double-jointed coupling short 3 Double-jointed coupling with sleeve					Sleeve length H_s [mm]		
		▼					▼		
_ / 9 4		_ . _		5 5 . _ / _ / _ / _ / _					
▲		▲		▲		▲		▲	
Size 14 to 38 ⁷⁾	Elastomeric element hardness	98 Sh A (red) 92 Sh A (yellow) 80 Sh A (blue) 64 Sh D (green) 72 Sh D (grey)	0 1 5 6 7	Aluminium design up to Size 38	A	Bore ø d₃^{F7} (see Table)	Bore ø d₃^{F7} (see Table)	Operating speed n_s [rpm] for sleeve	

Example: 38 / 940.055.A / Ød₃ 30 / Ød₃ 30

- 1) Recommended hub / shaft tolerance: F7 / k6
- 2) Transmittable torques dependent on bore, see page 28.
- 3) Also applicable for double-jointed design
- 4) Not valid for designs with sleeve (see diagram: "Permitted speeds for sleeve" on page 26)
- 5) Mass moments of inertia and weights are valid for one elastomeric element
- 6) Mass moments of inertia and weights are valid for maximum bore
- 7) Further Sizes available on request

ROBA®-ES with split clamping hubs

Sizes 14 to 65

Single-jointed coupling / Type 940. _ 33. _

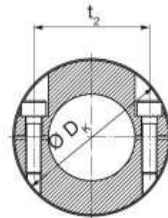
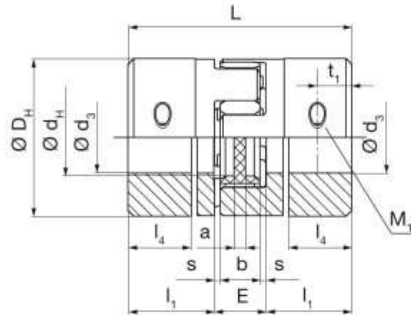

Technical Data and Main Dimensions			Size								
			14	19	24	28	38	42	48	55	65
Minimum hub bore ^{1) 2)}	$d_3^{H7}_{min}$	[mm]	8	8	10	14	18	22	22	40	45
Maximum hub bore ^{1) 2)}	$d_3^{H7}_{max}$	[mm]	15	20	28	35	45	50	55	70	80
Maximum speed ^{3) 4)}	n_{max}	[rpm]	12600	9300	7000	5600	4700	4000	3700	3300	3000
Tightening torque clamping screws	T_A	[Nm]	1.4	10	10	25	25	48	84	84	84

Mass moments of inertia J [10⁻³ kgm²] ^{5) 6)}

	Size	14	19	24	28	38	42	48	55	65
Elastomeric element		0.0005	0.0012	0.0067	0.0154	0.042	0.09	0.143	0.248	0.474
Split clamping hub		0.0041	0.0193	0.077	0.176	0.5003	3.045	5.051	9.536	17.693
Single-jointed coupling short		0.0087	0.0398	0.1607	0.3674	1.0426	6.18	10.245	19.32	35.86
Sleeve with $H_s = 1000$ mm		0.075	0.27	0.74	1.33	2.42	14.33	29.7	48.94	71.43
Sleeve with 1000 mm tube		0.071	0.236	0.676	1.202	1.917	10.676	24.89	41.167	54.082

Weights [kg] ^{5) 6)}

	Size	14	19	24	28	38	42	48	55	65
Elastomeric element		0.0048	0.007	0.019	0.037	0.054	0.081	0.104	0.149	0.216
Split clamping hub		0.0294	0.076	0.16	0.258	0.475	2.104	2.867	3.95	5.737
Single-jointed coupling short		0.0636	0.159	0.339	0.553	1.004	4.289	5.838	8.049	11.69
Sleeve with $H_s = 1000$ mm		0.595	1.036	1.323	1.631	2.101	9.429	15.764	18.009	21.351
Sleeve with 1000 mm tube		0.574	0.86	1.22	1.477	1.705	7.383	13.561	15.193	16.622

Dimensions	Size									
	14	19	24	28	38	42	48	55	65	
a	2	3	4	5	6	6	5	9	8	
b	10	12	14	15	18	20	21	22	26	
D_H	30	40	55	65	80	95	105	120	135	
D_K	32.2	47	58	71	83	99	106.5	122	136	
d_H	10.5	18	27	30	38.5	46	51	60	68	
E	13	16	18	20	24	26	28	30	35	
L	50	66	78	90	114	126	140	160	185	
L_2	71	92	112	128	158	174	192	218	252	
L_3	dependent on L_R									
$L_{R min}$	76.5	103	117	133	169	184	204	223	267	
$L_{R max}$	2008.5	2016	2016	2018	2026	2022	2026	3023	3037	
l_1	18.5	25	30	35	45	50	56	65	75	
l_2	34	42	52	58	68	74	80	88	102	
$H_{S min}$	68	87	101	115	143	162	178	200	230	
$H_{S max}$	2000	2000	2000	2000	2000	2000	2000	3000	3000	
l_4	14.25	17	22	26	32	39	43	53.5	56.5	
M_1	M3	M6	M6	M8	M8	M10	M12	M12	M12	
s	1.5	2	2	2.5	3	3	3.5	4	4.5	
t_1	7	8.5	12	13.5	16	20	22	26	27.5	
t_2	22	28	42	48	60	72	72	90	104	

ROBA[®]-ES with split clamping hubs

Sizes 14 to 65

Double-jointed coupling short / Type 942..33..

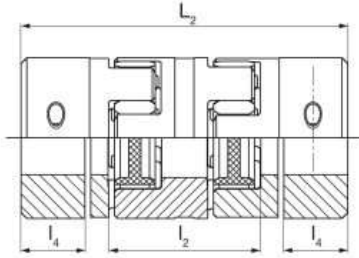

Double-jointed coupling with sleeve / Type 943..33..

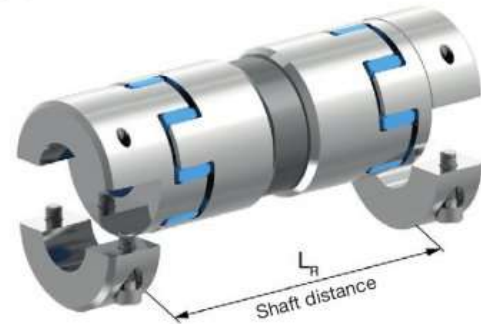
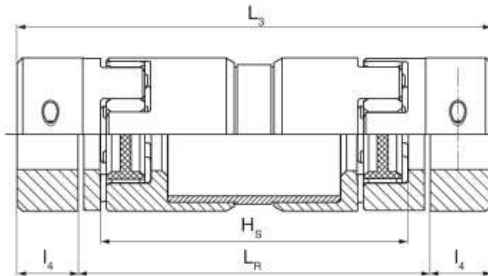

Order Number

		0 Single-jointed coupling 2 Double-jointed coupling short 3 Double-jointed coupling with sleeve						Shaft distance L_r [mm]
		▼						▼
		9 4 . . 3 3 . . / . . / . . / . . / . .						
		▲						▲
Size 14 to 65 ⁷⁾	Elastomeric element hard- ness	98 Sh A (red) 92 Sh A (yellow) 80 Sh A (blue) 64 Sh D (green) 72 Sh D (grey)	0 1 5 6 7	Aluminium design up to Size 38 Steel design from Size 42	A F	Bore \varnothing d_3^{H7} (see Table)	Bore \varnothing d_3^{H7} (see Table)	Operating speed n_s [rpm] for sleeve

Example: 42 / 940.033.F / $\varnothing d_3$ 30 / $\varnothing d_3$ 30

- 1) Recommended hub / shaft tolerance: H7 / g6
- 2) Transmittable torques dependent on bore, see page 29.
- 3) Also applicable for double-jointed design
- 4) Not valid for designs with sleeve (see diagram: "Permitted speeds for sleeve" on page 26)
- 5) Mass moments of inertia and weights are valid for one elastomeric element
- 6) Mass moments of inertia and weights are valid for maximum bore
- 7) Further Sizes available on request

ROBA®-ES with aluminium shrink disk hubs

Sizes 14 to 38

Single-jointed coupling / Type 940._ 11.A

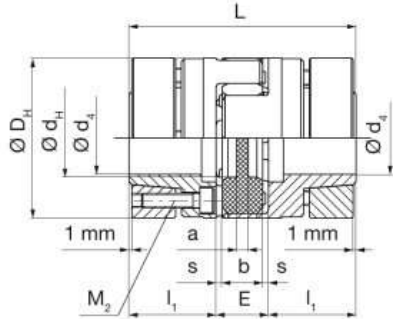

Technical Data and Main Dimensions			Size				
			14	19	24	28	38
Minimum hub bore ^{1) 2)}	$d_4^{H7_{min}}$	[mm]	6	10	15	19	20
Maximum hub bore ^{1) 2)}	$d_4^{H7_{max}}$	[mm]	14	20	28	38	45
Maximum speed ³⁾	n_{max}	[rpm]	28000	21000	15500	13200	10500
Tightening torque clamping screws	T_A	[Nm]	1.3	3	6	6	10

Mass moments of inertia J [10⁻³ kgm²] ^{4) 5)}

	Size	14	19	24	28	38
Elastomeric element		0.0005	0.0012	0.0067	0.0154	0.042
Shrink disk hub		0.0065	0.0313	0.134	0.304	0.929
Single-jointed coupling short		0.0135	0.0638	0.2747	0.6234	1.9

Weights [kg] ^{4) 5)}

	Size	14	19	24	28	38
Elastomeric element		0.0048	0.007	0.019	0.037	0.054
Shrink disk hub		0.046	0.12	0.271	0.412	0.852
Single-jointed coupling short		0.0968	0.247	0.561	0.861	1.758

Dimensions	Size				
	14	19	24	28	38
a	2	3	4	5	6
b	10	12	14	15	18
D _H	30	40	55	65	80
d _H	10.5	18	27	30	38.5
E	13	16	18	20	24
L	50	66	78	90	114
L ₂	71	92	112	128	158
I ₁	18.5	25	30	35	45
I ₂	34	42	52	58	68
M ₂	4xM3	6xM4	4xM5	8xM5	8xM6
s	1.5	2	2	2.5	3

We reserve the right to make dimensional and constructional alterations.

Stock program	Size					
	Bore	14	19	24	28	38
Ø10	x					
Ø11	x					
Ø12	x	x				
Ø14	x	x				
Ø15		x	x			
Ø16		x	x			
Ø18			x			
Ø19		x	x			
Ø20		x	x	x		
Ø22			x	x		
Ø24			x	x	x	
Ø25			x	x	x	
Ø28			x	x	x	
Ø30				x	x	
Ø32				x	x	
Ø35				x	x	
Ø38					x	
Ø40						

ROBA[®]-ES with aluminium shrink disk hubs

Sizes 14 to 38

Double-jointed coupling short / Type 942._ 11.A

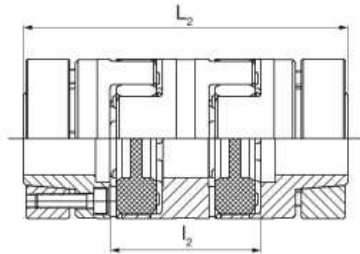

Order Number

- 0 Single-jointed coupling
- 2 Double-jointed coupling short

<p style="text-align: center;">_ / 9 4 _ . _ 1 1 . _ / _ / _</p>							
▲		▲		▲	▲	▲	▲
Size	Elastomeric element hardness	98 Sh A (red)	0	Aluminium design	A	Bore ø d₄^{H7}	Bore ø d₄^{H7}
14		92 Sh A (yellow)	1				
to		80 Sh A (blue)	5				
38⁶⁾		64 Sh D (green)	6				
		72 Sh D (grey)	7				
						(see Table)	

Example: 38 / 940.011.A / Ød₄ 30 / Ød₄ 30

- 1) Recommended hub / shaft tolerance: H7 / k6
- 2) Transmittable torques dependent on bore, see page 27.
- 3) Also applicable for double-jointed design
- 4) Mass moments of inertia and weights are valid for one elastomeric element
- 5) Mass moments of inertia and weights are valid for maximum bore
- 6) Further Sizes available on request

ROBA®-ES with steel shrink disk hubs

Sizes 14-32 to 65

Single-jointed coupling / Type 940._11._



Type 940._11.P – Sizes 14 to 38
Type 940._11.F – Sizes 42 to 65

Type 940.011.P
Sizes 14-32 to 28 acc. DIN 69002

Technical Data and Main Dimensions			Size											
			14-32	19-37.5	19	24-50	24	28	38	42	48	55	65	
Minimum hub bore ^{1) 2)}	$d_{4,min}$	[mm]	6	10	10	15	16	19	22	28	35	40	45	
Maximum hub bore ^{1) 2)}	$d_{4,max}$	[mm]	14	16	20	24	28	38	45	50	60	70	75	
DIN-bore ³⁾	d_4	[mm]	14	16	19	24	25	35	-	-	-	-	-	
Maximum speed	Single-jointed	n_{max}	[rpm]	28000	21000	21000	15500	15500	13200	10500	9000	8000	6300	5600
	Double-jointed short	n_{max}	[rpm]	-	-	-	-	-	-	-	9000	8000	6300	5600
Tightening torque clamping screws		T_A	[Nm]	1.3	3.0	3.0	6.0	6.0	6.0	10	30	52	58	100

Mass moments of inertia J [10⁻³ kgm²] ^{4) 5)}

	Size	14-32	19-37.5	19	24-50	24	28	38	42	48	55	65
Elastomeric element		0.0005	0.0012	0.0012	0.0067	0.0067	0.0154	0.042	0.09	0.143	0.248	0.474
Shrink disk hub		0.0128	0.0368	0.0471	0.136	0.202	0.433	1.332	2.948	4.809	9.099	17.287
Single-jointed coupling short		0.0261	0.0748	0.0954	0.2787	0.4107	0.8814	2.706	5.986	9.761	18.446	35.048

Weights [kg] ^{4) 5)}

	Size	14-32	19-37.5	19	24-50	24	28	38	42	48	55	65
Elastomeric element		0.0048	0.007	0.007	0.019	0.019	0.037	0.054	0.081	0.104	0.149	0.216
Shrink disk hub		0.086	0.174	0.185	0.348	0.418	0.606	1.256	2.022	2.62	3.754	5.766
Single-jointed coupling short		0.1768	0.355	0.377	0.715	0.855	1.249	2.566	4.125	5.344	7.657	11.748

Dimen- sions	Size											
	14-32	19-37.5	19	24-50	24	28	38	42	48	55	65	
a	2	4	4	4	4	5	5	5	5	9	8	
b	10	12	12	14	14	15	18	20	21	22	26	
D_H	32	37.5	40	50	55	65	80	95	105	120	135	
d_H	10.5	18	18	27	27	30	38	46	51	60	68	
d_6	17	19	22	29	30	40	46	55	60	72	77	
d_7 ³⁾	8.5	9.5	9.5	12.5	12.5	14.5	-	-	-	-	-	
E	13	16	16	18	18	20	24	26	28	30	35	
L	50	66	66	78	78	90	114	126	140	160	185	
L_2								174	192	218	252	
l_1	18.5	25	25	30	30	35	45	50	56	65	75	
l_2								74	80	88	102	
M_2	4 x M3	6 x M4	6 x M4	4 x M5	4 x M5	8 x M5	8 x M6	4 x M8	4 x M10	4 x M10	4 x M12	
s	1.5	2.0	2.0	2.0	2.0	2.5	3.0	3.0	3.5	4.0	4.5	
t_2	3	4	4	5	5	5	5	5	6	7	7	

We reserve the right to make dimensional and constructional alterations.

ROBA[®]-ES with steel shrink disk hubs

Sizes 14-32 to 65

Double-jointed coupling short / Type 942._ 11._

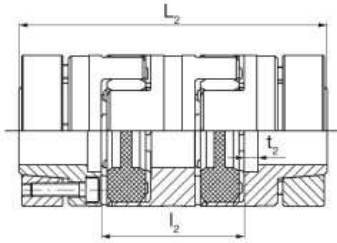

Order Number

- 0 Single-jointed coupling
- 2 Double-jointed coupling short[®]

Bore ϕ
 d_4^{H6} up to Size 38 | d_4^{H7} from Size 42
 (see Table)

_ / 9		4	_ . _		1	1	_ / _ / _ / _	
Size 14-32 to 65 ⁷⁾	Elastomeric element hardness	98 Sh A (red) 92 Sh A (yellow) 80 Sh A (blue) 64 Sh D (green) 72 Sh D (grey)	0 1 5 6 7	Steel design up to Size 38 Steel design from Size 42	P F	Bore ϕ d_4^{H6} up to Size 38 d_4^{H7} from Size 42 (see Table)		Design - DIN - No values for standard

Example: 42 / 940.011.F / ϕd_4 30 / ϕd_4 30

- 1) Recommended hub / shaft tolerance: H6 / k6, from Size 42: H7 / k6
- 2) Transmittable torques dependent on bore, see page 27.
- 3) Elastomeric elements with DIN bores only available with 98 Sh A (red), Type 940.011.P
- 4) Mass moments of inertia and weights are valid for one elastomeric element
- 5) Mass moments of inertia and weights are valid for maximum bore
- 6) Double-joint designs are only available from Size 42.

7) Further Sizes available on request

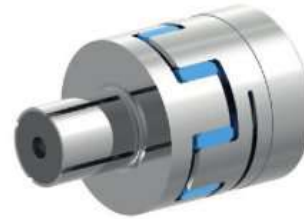
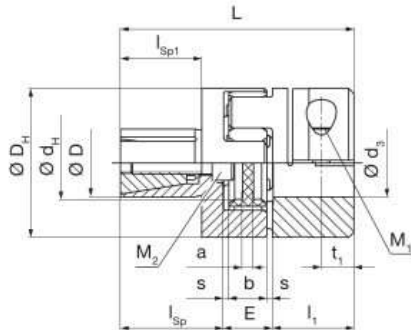
ROBA®-ES with expansion hub and clamping hub
Sizes 14 to 28
Single-jointed coupling / Type 940._ 04._

Technical Data and Main Dimensions			Size			
			14	19	24	28
Minimum hub bore ^{1) 2)}	$d_s^{F7}_{min}$	[mm]	6	6	8	10
Maximum hub bore ^{1) 2)}	$d_s^{F7}_{max}$	[mm]	15	20	28	35
Diameter expansion hub	D_{H7}	[mm]	12	20	25	35
Maximum speed	n_{max}	[rpm]	12600	9300	7000	5600
Tightening torque M_2	T_A	[Nm]	5.8	10.1	24	48

Mass moments of inertia J [10⁻³ kgm²] ^{3) 4)}

	Size	14	19	24	28
Elastomeric element		0.0005	0.0012	0.0067	0.0154
Clamping hub		0.0028	0.0193	0.076	0.168
Expansion hub		0.0019	0.0097	0.043	0.081
Single-jointed coupling short		0.0052	0.0302	0.1257	0.2644

Weights [kg] ^{3) 4)}

	Size	14	19	24	28
Elastomeric element		0.0048	0.007	0.019	0.037
Clamping hub		0.02	0.076	0.159	0.245
Expansion hub		0.023	0.071	0.188	0.286
Single-jointed coupling short		0.0478	0.154	0.366	0.568

Dimensions	Size			
	14	19	24	28
a	2	3	4	5
b	10	12	14	15
D_H	30	40	55	65
D_K	32.2	47	56.4	72.6
d_H	10.5	18	27	30
E	13	16	18	20
L	42.5	69	86	99
l₁	11	25	30	35
l_{Sp}	18.5	28	38	44
l_{Sp1}	12.5	20	30	36
M₁	M3	M6	M6	M8
M₂	M5	M6	M8	M10
s	1.5	2	2	2.5
t₁	5.5	12	12	13.5

Order Number

0 Single-jointed coupling

_ / 9 4		_ . _		0 4	.	_ / _ / _
▲		▲		▲	▲	▲
Size 14 to 28 ⁵⁾	Elastomeric element hardness	98 Sh A (red) 92 Sh A (yellow) 80 Sh A (blue) 64 Sh D (green) 72 Sh D (grey)	0 1 5 6 7	Aluminium design	A	o D _{h7} (see Table)
						Bore o d ₃ ^{F7} (see Table)

Example: 28 / 940.004.A / ØD 35 / Ød₃ 30

- 1) Recommended fit connection for expansion hub: F7 / h7
- 2) Transmittable torques dependent on bore, see page 29.
- 3) Mass moments of inertia and weights are valid for one elastomeric element
- 4) Mass moments of inertia and weights are valid for maximum bore
- 5) Further Sizes available on request

ROBA®-ES Coupling Dimensioning

1. Approximate calculation of the coupling torque:

1.1. T_N from the nominal power

$$T_N = \frac{9550 \times P_{AN/LN}}{n}$$

1.2. Dynamic torques T_S and T_W (5.1 and 5.2):

Drive-side excitation:

$$\text{Peak torque: } T_S = T_{AS} \times \frac{J_L}{J_A + J_L} \times S_A$$

$$\text{Alternating torque: } T_W = T_{AW} \times \frac{J_L}{J_A + J_L} \times V_R$$

Load-side excitation:

$$\text{Peak torque: } T_S = T_{LS} \times \frac{J_A}{J_A + J_L} \times S_L$$

$$\text{Alternating torque: } T_W = T_{LW} \times \frac{J_A}{J_A + J_L} \times V_R$$

2. Comparison of torques occurring in the coupling with the permitted torques

The coupling must be dimensioned so that the loads occurring do not exceed the permitted values in any operating state.

2.1. Load due to nominal torque

$$T_{KN} \geq T_N \times S_0$$

2.2. Load due to torque impacts (5.3)

$$T_{Kmax} \geq T_S \times S_Z \times S_0 + T_N \times S_0$$

2.3. Load due to resonance passing through (5.4)

$$T_{Kmax} \geq T_S \times S_Z \times S_0 \times V_R + T_N \times S_0$$

2.4. Load due to constantly alternating torque – cycle operation (5.5 and 5.6)

Permitted alternating torque on coupling:

$$T_{KW} = 0.25 \times T_{KN} \quad (\text{for aluminium hubs})$$

$$T_{KW} = 0.35 \times T_{KN} \quad (\text{for steel hubs})$$

$$T_{KW} \geq T_W \times S_0 \times S_f$$

6

3. Inspection of permitted misalignments

$$\Delta K_a \geq \Delta W_a \times S_0$$

$$\Delta K_f \geq \Delta W_f \times S_0 \times S_n$$

$$\Delta K_w \geq \Delta W_w \times S_0 \times S_n$$

If more than one kind of misalignment occurs at the same time, please observe Fig. 2 (page 30).

4. Frictional locking inspection on hub connection

$T_R > T_{max}$: T_{max} is the maximum torque occurring in the coupling.

Values for T_R can be found on pages 27 to 29.

5. Explanations

5.1. The torque determination on the coupling is applicable if the shaft coupling in the system is the torsionally softest element, and therefore the system can be considered as a double-mass oscillator. If this is not the case, the calculation of the torque on the coupling requires a more detailed calculation procedure.

5.2. The impact factors S_A / S_L describe the impact progression. A rectangular progression of the peak torque is the heaviest impact ($S_A/S_L = 2.0$). A flat sinus progression of the peak torque is a light impact ($S_A/S_L = 1.2$).

5.3. T_S , the peak torque in the coupling, is the maximum torque on the coupling during the impact minus the system torque having an effect on the coupling during normal operation.

$$T_S = T_{max, impact} - T_N$$

5.4. If a drive is operated supercritically, meaning that the operating speed n lies above the resonance speed n_r , then resonance passing through causes particular loads.

If the resonance passes through quickly below the operating speed, only a few resonance peaks occur. The alternating torque in resonance can therefore be compared to the maximum torque on the coupling (see also 5.6).

5.5. S_f takes the frequency dependency of lifetime into account. The frequency dependency is first taken into account above 5 Hz.

5.6. On appreciable vibration excitation, the resonance must be moved out of the operating range by selecting a suitable torsional spring rigidity of the coupling.

ROBA®-ES Coupling Dimensioning

Service Factors for Coupling Dimensioning

V_R = Resonance factor

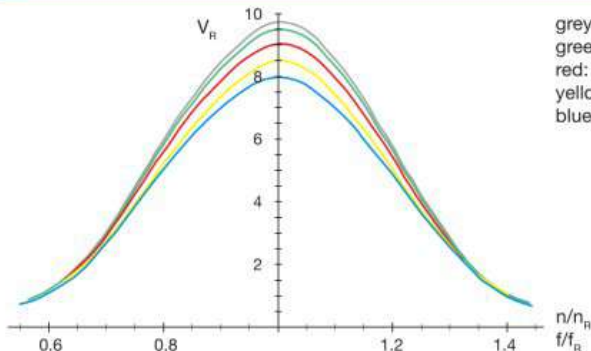

grey: Elastomeric element 72 Sh D
 green: elastomeric element 64 Sh D
 red: elastomeric element 98 Sh A
 yellow: elastomeric element 92 Sh A
 blue: elastomeric element 80 Sh A

n_R = Resonance speed

$$n_R = \frac{30}{\pi} \sqrt{C_{Tdyn} \frac{J_A + J_L}{J_A \times J_L}} \text{ [rpm]}$$

f_R = Resonance frequency

$$f_R = \frac{1}{2\pi} \sqrt{C_{Tdyn} \frac{J_A + J_L}{J_A \times J_L}} \text{ [s}^{-1}\text{]}$$

S_n = Speed factor

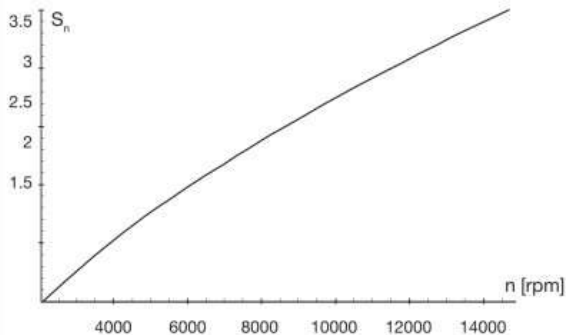

S_Z = Start-up factor/impact frequency

S/h	0 - 100	101 - 200	201 - 400	401 - 800	801 - 1600
S _Z	1	1.2	1.4	1.6	1.8

S_δ = Safety factor for temperature

T [°C]	-30 °C / +30 °C	+60 °C	+90 °C
S _δ	1	1.5	2

S_f = Frequency factor

f in H _z	≤ 5	> 5
S _f	1	$\sqrt{\frac{f}{5}}$

S_L or S_A = Impact factor

Impacts	S _A or S _L
Light impacts	1.2
Medium impacts	1.6
Heavy impacts	2.0

f shows the load alternation per second (Hz = s⁻¹)

Terms

P _{AN/LN}	[kW]	Drive-side/load-side power
T _R	[Nm]	Transmittable torque (frictional locking, Tables pages 27 to 29)
T _{AS/AW}	[Nm]	Excitational torque drive end
T _{LS/LW}	[Nm]	Excitational torque load side
T _N	[Nm]	System torque
T _W	[Nm]	System alternating torque
T _S	[Nm]	Peak torque
T _{max}	[Nm]	Maximum torque in the coupling
T _{KN}	[Nm]	Permitted nominal torque
T _{Kmax}	[Nm]	Permitted maximum torque
T _{KW}	[Nm]	Permitted permanent alternating torque
J _A	[kgm ²]	Mass moment of inertia, drive end
J _L	[kgm ²]	Mass moment of inertia, load side
ΔK _A	[mm]	Permitted axial displacement
ΔK _r	[mm]	Permitted radial misalignment
ΔK _w	[°]	Permitted angular misalignment

ΔW _A	[mm]	Axial shaft misalignment
ΔW _r	[mm]	Radial shaft misalignment
ΔW _w	[°]	Angular shaft misalignment
c _T	[Nm/rad]	Torsional spring rigidity
n	[rpm]	Nominal speed
n _R	[rpm]	Resonance speed
S _{AVL}	[-]	Impact factor drive end /load side
S _n	[-]	Speed factor
S _Z	[-]	Start-up factor/impact frequency
S _δ	[-]	Temperature factor
S _f	[-]	Frequency factor
V _R	[-]	Resonance factor
f	[1/s]=[Hz]	Load factor
f _R	[Hz]	Resonance frequency

Technical Explanations

ROBA®-ES Elastomeric Elements

Elastomeric element hardness [Shore]	Colour	Permitted temperature range	
		Permanent temperature	Temporary max. temperature
80 Sh A	blue	-50 to +80 °C	-60 to +120 °C
92 Sh A	yellow	-40 to +90 °C	-50 to +120 °C
98 Sh A	red	-30 to +90 °C	-40 to +120 °C
64 Sh D	green	-30 to +100 °C	-40 to +140 °C
72 Sh D	grey	-20 to +110 °C	-20 to +150 °C

Torques

Size	Torques									
	Elastomeric element hardness									
	80 Sh A (blue)		92 Sh A (yellow)		98 Sh A (red)		64 Sh D (green)		72 Sh D (grey)	
	T _{KN} [Nm]	T _{K max} [Nm]	T _{KN} [Nm]	T _{K max} [Nm]	T _{KN} [Nm]	T _{K max} [Nm]	T _{KN} [Nm]	T _{K max} [Nm]	T _{KN} [Nm]	T _{K max} [Nm]
14	4	8	8	16	13	26	16	32	-	-
19	5	10	10	20	17	34	21	42	27	54
24	17	34	35	70	60	120	75	150	95	190
28	46	92	95	190	160	320	200	400	260	520
38	95	190	190	380	325	650	405	810	525	1050
42	125	250	265	530	450	900	560	1120	725	1450
48	150	300	310	620	525	1050	655	1310	850	1700
55	200	400	410	820	685	1370	825	1650	-	-
65	450	900	900	1800	1040	2080	1250	2500	-	-

Please Observe: To determine the coupling torque, observe the "ROBA®-ES Coupling Dimensioning" starting on page 22!

Spring rigidity ¹⁾

Size	Torsional spring rigidity										Radial spring rigidity					
	static C _{T stat.}					dynamic C _{T dyn.}					relative C _{T H rel.}	static C _r				
	80 Sh A	92 Sh A	98 Sh A	64 Sh D	72 Sh D	80 Sh A	92 Sh A	98 Sh A	64 Sh D	72 Sh D		Sleeve	80 Sh A	92 Sh A	98 Sh A	64 Sh D
	[Nm/rad.]										[10 ⁶ Nm mm/rad.]	[N/mm]				
14	50	80	120	230	-	120	240	300	730	-	0.65	180	300	470	960	-
19	350	820	900	1400	2100	1050	1800	2200	4200	3200	2.18	700	1200	2100	2700	4100
24	820	2300	3700	4500	7200	1300	4800	7600	10800	10500	6.26	800	1900	2800	4200	7100
28	1300	3800	4200	7000	12500	2200	6800	10100	17200	23000	11.15	950	2100	3500	4900	9200
38	2000	5600	7400	9000	25000	3400	11900	19900	30500	45000	18.11	1300	2900	4800	5600	12000
42	3500	9800	13800	15000	45000	5950	20500	31100	64900	80000	109.66	3400	4100	5400	6900	16000
48	4300	12000	15100	28500	62000	7300	22800	44900	102800	110000	254.50	3750	4500	6200	8200	18000
55	5100	14200	20500	56300	-	8300	25800	48200	117400	-	421.75	4730	5680	8200	22500	-
65	6800	19100	32800	90200	-	11500	36200	67400	164000	-	555.18	6360	7640	13120	36000	-
Only for type 940_11.P																
14-32	50	80	120	230	-	120	240	300	730	-	-	180	300	470	960	-
19-37.5	280	660	720	1120	-	840	1440	1760	3360	-	-	560	960	1680	2160	-
24-50	600	1700	2700	3300	-	1000	3600	5700	8100	-	-	600	1500	2100	3200	-

1) The C_r-value of a double-jointed coupling can be roughly calculated as follows:

$$C_{T ges.} = \frac{1}{\frac{2}{C_T} + \frac{H_s [mm] - 2 E [mm]}{C_{T H rel.}}}$$

Technical Explanations

Permitted Misalignment Values

Size	Shaft misalignments Basic Type										
	Axial ΔK_s 80/92/98 Sh A 64/72 Sh D [mm]	ΔK_r 80 Sh A [mm]	ΔK_r 92 Sh A [mm]	ΔK_r 98 Sh A [mm]	ΔK_r 64 Sh D [mm]	ΔK_r 72 Sh D [mm]	ΔK_w 80 Sh A [°]	ΔK_w 92 Sh A [°]	ΔK_w 98 Sh A [°]	ΔK_w 64 Sh D [°]	ΔK_w 72 Sh D [°]
Misalignment values Basic Type											
14	1.0	0.21	0.15	0.09	0.06	-	1.1	1.0	0.9	0.8	-
19	1.2	0.15	0.1	0.06	0.04	0.03	1.1	1.0	0.9	0.8	0.7
24	1.4	0.18	0.14	0.1	0.07	0.04	1.1	1.0	0.9	0.8	0.7
28	1.5	0.2	0.15	0.11	0.08	0.05	1.3	1.0	0.9	0.8	0.7
38	1.8	0.22	0.17	0.12	0.09	0.06	1.3	1.0	0.9	0.8	0.7
42	2.0	0.24	0.19	0.14	0.1	0.07	1.3	1.0	0.9	0.8	0.7
48	2.1	0.26	0.21	0.16	0.11	0.08	1.3	1.0	0.9	0.8	0.7
55	2.2	0.28	0.24	0.17	0.12	-	1.3	1.0	0.9	0.8	-
65	2.6	0.3	0.25	0.18	0.13	-	1.3	1.0	0.9	0.8	-
Only available on P-design											
14-32	1.0	0.21	0.15	0.09	0.06	-	1.1	1.0	0.9	0.8	-
19-37.5	1.2	0.15	0.1	0.06	0.04	-	1.1	1.0	0.9	0.8	-
24-50	1.4	0.18	0.14	0.1	0.07	-	1.1	1.0	0.9	0.8	-
Misalignment values with connection piece											
											per side
14	2.0	0.42	0.30	0.18	0.12	-	1.1	1.0	0.9	0.8	-
19	2.4	0.3	0.20	0.12	0.08	0.06	1.1	1.0	0.9	0.8	0.7
24	2.8	0.36	0.28	0.20	0.14	0.08	1.1	1.0	0.9	0.8	0.7
28	3.0	0.4	0.30	0.22	0.16	0.10	1.3	1.0	0.9	0.8	0.7
38	3.6	0.44	0.34	0.24	0.18	0.12	1.3	1.0	0.9	0.8	0.7
42	4.0	0.48	0.38	0.28	0.20	0.14	1.3	1.0	0.9	0.8	0.7
48	4.2	0.52	0.42	0.32	0.22	0.16	1.3	1.0	0.9	0.8	0.7
55	4.4	0.56	0.48	0.34	0.24	-	1.3	1.0	0.9	0.8	-
65	5.2	0.6	0.50	0.36	0.26	-	1.3	1.0	0.9	0.8	-
Misalignment values with sleeve											
											per side
$(L_s - 2 \times l_1 - E) \times A$ (Calculation factor)											
14	2.0	A = 0.0097	A = 0.0087	A = 0.0079	A = 0.0070	A = 0.0061	1.1	1.0	0.9	0.8	-
19	2.4						1.1	1.0	0.9	0.8	0.7
24	2.8						1.1	1.0	0.9	0.8	0.7
28	3.0	A = 0.0113	A = 0.0087	A = 0.0079	A = 0.0070	A = 0.0061	1.3	1.0	0.9	0.8	0.7
38	3.6						1.3	1.0	0.9	0.8	0.7
42	4.0						1.3	1.0	0.9	0.8	0.7
48	4.2						1.3	1.0	0.9	0.8	0.7
55	4.4						1.3	1.0	0.9	0.8	-
65	5.2	1.3	1.0	0.9	0.8	-					

Technical Explanations

Permitted Speeds (critical bending speed) for Sleeve

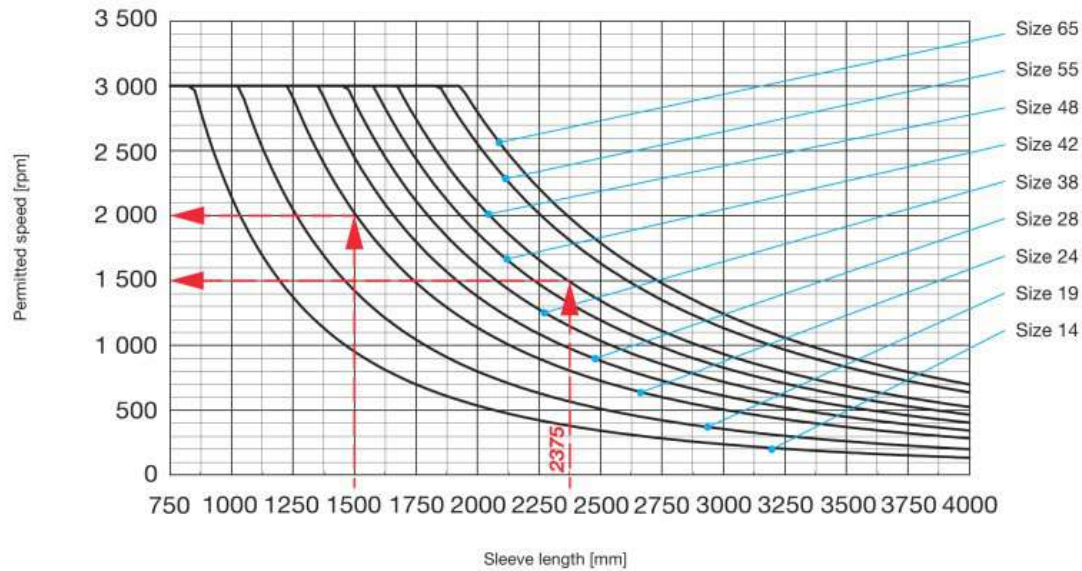

Examples

- ROBA®-ES, Size 48:

Sleeve length: $H_s = 2375$ mm
 => permitted speed: **1500 rpm**

- ROBA®-ES, Size 24:

Sleeve length: $H_s = 1500$ mm
 => permitted speed: **2000 rpm**

Using the coupling at high speeds

- Please keep to the maximum speeds defined in the catalogue. Higher speeds are only permitted after contacting the manufacturers.
- Please operate designs with sleeve at subcritical levels.
- Both hub variants clamping hub and split clamping hub may only be used within a limited speed range. At very high speeds, shrink disk hubs and key hubs (press fit) should be used.
- We recommend balancing the coupling in individual parts or complete.
- Shaft misalignments should be kept as low as possible to increase the smooth running of a system.
- When using double cardanic shafts, axial animation of the middle coupling part is possible due to operating speed and misalignment. In order to avoid this animation, please minimise the shaft misalignment.

Technical Explanations

Transmittable Torques

Shrink disk hubs made of aluminium Type 940_11.A			Bore	Size				
				14	19	24	28	38
Frictionally-locking Transmittable torques Shrink disk hubs made of aluminium	T _R	[Nm]	Ø6	13.5	-	-	-	-
			Ø7	16.5	-	-	-	-
			Ø8	19.0	-	-	-	-
			Ø9	22.5	-	-	-	-
			Ø10	19.0	41	-	-	-
			Ø11	22.5	48	-	-	-
			Ø12	26.5	58	-	-	-
			Ø14	34.5	77	-	-	-
			Ø15	-	87	67	-	-
			Ø16	-	88	78	-	-
			Ø17	-	107	89	-	-
			Ø18	-	117	100	-	-
			Ø19	-	126	109	194	-
			Ø20	-	136	121	214	247
			Ø22	-	-	143	255	299
			Ø24	-	-	166	296	352
			Ø25	-	-	178	317	379
			Ø28	-	-	212	381	463
			Ø30	-	-	-	423	519
			Ø32	-	-	-	462	567
Ø35	-	-	-	528	653			
Ø38	-	-	-	594	739			
Ø40	-	-	-	-	797			
Ø42	-	-	-	-	855			
Ø45	-	-	-	-	942			

Suitable for H7 / k6
With larger fit clearance, the transmittable torque is reduced.

Shrink disk hubs made of steel Type 940_11.P			Bore	Size						
				14-32	19-37.5	19	24-50	24	28	38
Frictionally-locking Transmittable torques Shrink disk hubs made of steel	T _R	[Nm]	Ø6	4.0	-	-	-	-	-	
			Ø7	8.0	-	-	-	-	-	
			Ø8	11.5	-	-	-	-	-	
			Ø9	15.0	-	-	-	-	-	
			Ø10	19.5	17	7	-	-	-	
			Ø11	23.5	25	13	-	-	-	
			Ø12	10.5	35	22	-	-	-	
			Ø14	21.5	59	44	-	-	-	
			Ø15	-	72	56	18	-	-	
			Ø16	-	85	68	29	20	-	
			Ø17	-	-	81	42	31	-	
			Ø18	-	-	94	54	43	-	
			Ø19	-	-	106	66	54	71	
			Ø20	-	-	120	79	67	91	
			Ø22	-	-	-	109	95	134	111
			Ø24	-	-	-	139	124	179	165
			Ø25	-	-	-	-	139	203	193
			Ø28	-	-	-	-	186	277	282
			Ø30	-	-	-	-	-	329	346
			Ø32	-	-	-	-	-	375	395
Ø35	-	-	-	-	-	460	500			
Ø38	-	-	-	-	-	548	608			
Ø40	-	-	-	-	-	-	685			
Ø42	-	-	-	-	-	-	761			
Ø45	-	-	-	-	-	-	879			

Suitable for H6 / k6
With larger fit clearance, the transmittable torque is reduced.

Shrink disk hubs made of steel Type 940_11.F			Bore	Size			
				42	48	55	65
Frictionally-locking Transmittable torques Shrink disk hubs made of steel	T _R	[Nm]	Ø28	215	-	-	-
			Ø30	285	-	-	-
			Ø32	330	-	-	-
			Ø35	450	475	-	-
			Ø38	570	620	-	-
			Ø40	655	720	555	-
			Ø42	745	820	655	-
			Ø45	875	980	825	1195
			Ø48	1010	1150	1000	1425
			Ø50	1105	1265	1120	1595
			Ø52	-	1350	1245	1680
			Ø55	-	1530	1430	1945
			Ø58	-	1720	1625	2210
			Ø60	-	1840	1755	2395
			Ø62	-	-	1890	2575
			Ø65	-	-	2090	2855
			Ø68	-	-	2295	3140
Ø70	-	-	2435	3330			
Ø72	-	-	-	3525			
Ø75	-	-	-	3825			

Suitable for H7 / k6
With larger fit clearance, the transmittable torque is reduced.

Technical Explanations

Transmittable Torques

Clamping hubs Type 94_..00_		Bore	Size										
			14	19	24	28	38	42	48	55	65		
Frictionally-locking Transmittable torques Clamping hubs	T_R	[Nm]	Ø6	2.5	-	-	-	-	-	-	-	-	-
			Ø7	3.0	-	-	-	-	-	-	-	-	-
			Ø8	3.4	-	-	-	-	-	-	-	-	-
			Ø9	3.8	-	-	-	-	-	-	-	-	-
			Ø10	4.2	23	-	-	-	-	-	-	-	-
			Ø11	4.7	25	-	-	-	-	-	-	-	-
			Ø12	5.1	27	-	-	-	-	-	-	-	-
			Ø14	6.0	32	-	-	-	-	-	-	-	-
			Ø15	6.4	34	34	-	-	-	-	-	-	-
			Ø16	-	36	36	-	-	-	-	-	-	-
			Ø18	-	41	41	-	-	-	-	-	-	-
			Ø19	-	43	43	79	-	-	-	-	-	-
			Ø20	-	45	45	83	83	-	-	-	-	-
			Ø22	-	-	50	91	91	-	-	-	-	-
			Ø24	-	-	54	100	100	-	-	-	-	-
			Ø25	-	-	57	104	104	-	-	-	-	-
			Ø28	-	-	63	116	116	208	-	-	-	-
			Ø30	-	-	-	124	124	228	-	-	-	-
			Ø32	-	-	-	133	133	248	-	-	-	-
			Ø35	-	-	-	145	145	280	350	-	-	-
			Ø38	-	-	-	-	158	315	390	-	-	-
			Ø40	-	-	-	-	166	340	420	340	-	-
			Ø42	-	-	-	-	174	365	455	365	-	-
			Ø45	-	-	-	-	187	404	505	405	545	-
			Ø48	-	-	-	-	-	442	560	435	590	-
			Ø50	-	-	-	-	-	470	600	465	630	-
			Ø52	-	-	-	-	-	-	640	490	662	-
			Ø55	-	-	-	-	-	-	705	525	710	-
			Ø58	-	-	-	-	-	-	-	570	764	-
			Ø60	-	-	-	-	-	-	-	600	800	-
Ø62	-	-	-	-	-	-	-	625	840	-			
Ø65	-	-	-	-	-	-	-	665	900	-			
Ø68	-	-	-	-	-	-	-	700	954	-			
Ø70	-	-	-	-	-	-	-	740	990	-			
Ø72	-	-	-	-	-	-	-	-	1032	-			
Ø75	-	-	-	-	-	-	-	-	1095	-			
Ø78	-	-	-	-	-	-	-	-	1158	-			
Ø80	-	-	-	-	-	-	-	-	1200	-			

Clamping hubs Compact Type 94_..55_		Bore	Size						
			14	19	24	28	38		
Frictionally-locking Transmittable torques Clamping hubs Compact	T_R	[Nm]	Ø5	5	-	-	-	-	-
			Ø6	6	-	-	-	-	-
			Ø7	7	-	-	-	-	-
			Ø8	8	18	-	-	-	-
			Ø9	9	20	-	-	-	-
			Ø10	10	23	23	-	-	-
			Ø11	11	25	25	-	-	-
			Ø12	12	27	27	-	-	-
			Ø13	-	29	29	-	-	-
			Ø14	-	32	32	58	-	-
			Ø15	-	34	34	62	98	-
			Ø16	-	36	36	66	105	-
			Ø17	-	38	38	71	110	-
			Ø18	-	41	41	75	118	-
			Ø19	-	43	43	79	124	-
			Ø20	-	45	45	83	131	-
			Ø21	-	-	48	87	137	-
			Ø22	-	-	50	91	144	-
			Ø23	-	-	52	95	150	-
			Ø24	-	-	54	100	157	-
			Ø25	-	-	57	104	163	-
			Ø26	-	-	59	108	170	-
			Ø27	-	-	61	112	176	-
			Ø28	-	-	63	116	183	-
			Ø29	-	-	66	120	190	-
			Ø30	-	-	68	124	196	-
			Ø31	-	-	70	129	203	-
			Ø32	-	-	72	133	209	-
			Ø33	-	-	-	137	216	-
			Ø34	-	-	-	141	222	-
Ø35	-	-	-	145	229	-			
Ø36	-	-	-	-	235	-			
Ø37	-	-	-	-	242	-			
Ø38	-	-	-	-	248	-			
Ø39	-	-	-	-	255	-			
Ø40	-	-	-	-	261	-			
Ø41	-	-	-	-	268	-			
Ø42	-	-	-	-	274	-			
Ø43	-	-	-	-	281	-			
Ø44	-	-	-	-	288	-			
Ø45	-	-	-	-	294	-			

Technical explanations

Transmittable Torques

Split Clamping Hubs Type 94_._33_.		Bore	Size										
			14	19	24	28	38	42	48	55	65		
		Ø8	4	18									
		Ø9	4.5	20									
		Ø10	5	23	23								
		Ø11	5.5	25	25								
		Ø12	6	27	27								
		Ø13	6.5	29	29								
		Ø14	7	32	32	58							
		Ø15	7.5	34	34	62							
		Ø16		36	36	66							
		Ø17		38	38	71							
		Ø18		41	41	75	75						
		Ø19		43	43	79	79						
		Ø20		45	45	83	83						
		Ø21			48	87	87						
		Ø22			50	91	91	144	210				
		Ø23			52	95	95	150	220				
		Ø24			54	100	100	157	229				
		Ø25			57	104	104	163	239				
		Ø26			59	108	108	170	248				
		Ø27			61	112	112	176	258				
		Ø28			63	116	116	183	267				
		Ø29				120	120	190	277				
		Ø30				124	124	196	287				
		Ø31				129	129	203	296				
		Ø32				133	133	209	306				
		Ø33				137	137	216	315				
		Ø34				141	141	222	325				
		Ø35				145	145	229	334				
		Ø36					149	235	344				
		Ø37					153	242	353				
		Ø38					158	248	363				
		Ø39					162	255	372				
		Ø40					166	261	382	382			
		Ø41					170	268	392	392			
		Ø42					174	274	401	401			
		Ø43					178	281	411	411			
		Ø44					182	288	420	420			
		Ø45					187	294	430	430	430		
		Ø46						301	439	439	439		
		Ø47						307	449	449	449		
		Ø48						314	458	458	458		
		Ø49						320	468	468	468		
		Ø50						327	478	478	478		
		Ø51							487	487	487		
		Ø52							497	497	497		
		Ø53							506	506	506		
		Ø54							516	516	516		
		Ø55							525	525	525		
		Ø56								535	535		
		Ø57								544	544		
		Ø58								554	554		
		Ø59								563	563		
		Ø60								573	573		
		Ø61								583	583		
		Ø62								592	592		
		Ø63								602	602		
		Ø64								611	611		
		Ø65								621	621		
		Ø66								630	630		
		Ø67								640	640		
		Ø68								649	649		
		Ø69								659	659		
		Ø70								669	669		
		Ø71									678		
		Ø72									688		
		Ø73									697		
		Ø74									707		
		Ø75									716		
		Ø76									726		
		Ø77									735		
		Ø78									745		
		Ø79									755		
		Ø80									764		

Expansion hubs Type 94_._4_.		Bore	Size				
			14	19	24	28	
Frictionally-locking Transmittable torques	T _R	[Nm]	Ø12	15.7			
			Ø20		36.6		
Suitable for F7 / h7 Expansion hubs made of steel	T _R	[Nm]	Ø25			84.4	
			Ø35				188

Technical Explanations

ROBA[®]-ES stands for flexible (E), backlash-free (S) shaft coupling. The device consists of two coupling hubs and a flexible, star-shaped intermediate ring (Fig. 1).

ROBA[®]-ES couplings are conceived specially for backlash-free operation at comparatively high speeds.

ROBA[®]-ES couplings are mainly used in measurement technology and control engineering as well as in control and procedure technology.

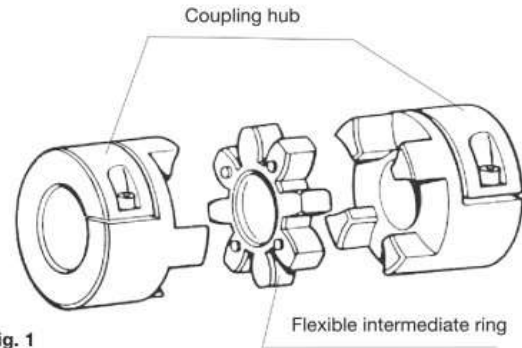

Fig. 1

Shaft Misalignments

The ROBA[®]-ES coupling compensates for radial, axial and angular shaft misalignments (Fig. 3) without losing their backlash-free function. However, the permitted misalignments indicated on page 25 must not simultaneously reach their maximum value. If more than one kind of misalignment takes place simultaneously, they influence each other. This means that the permitted misalignment values are dependent on one another, see Fig. 2. The sum total of the actual misalignments – in percent of the maximum value – must not exceed 100 %.

The permitted misalignment values given on page 25 refer to coupling operation at nominal torque, an ambient temperature of +30 °C and an operating speed of 1500 rpm.

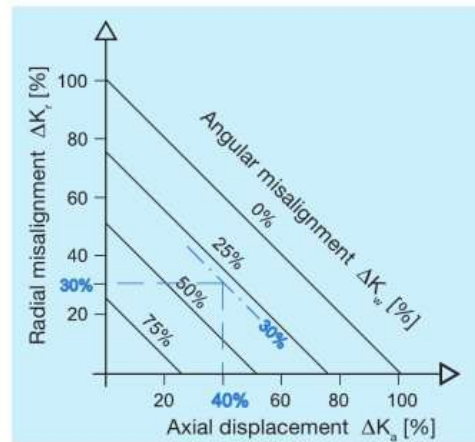

Fig. 2

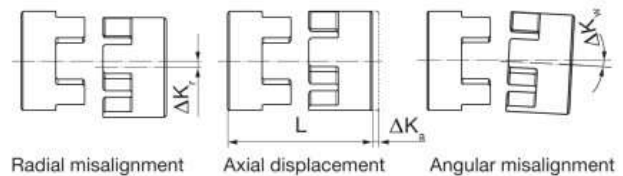

Fig. 3

Technical Explanations

State of Delivery

ROBA®-ES couplings are delivered manufacturer-assembled ready for installation.

The star-shaped intermediate ring is pressed into the specially designed claws (Fig. 4) under light pre-tension.

The principle of backlash-free torque transmission is possible due to this pre-tension.

ROBA®-ES couplings are delivered in four torque variations; that is with four different flexible intermediate rings varying in shore hardness and colour (see Type key page 24).

Due to the small structural dimensions and therefore the low mass moments of inertia, the device allows itself to be installed even into small installation spaces.

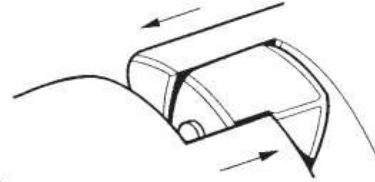

Fig. 4

Balancing

Key hubs and clamping hubs:

Key hubs and clamping hubs rotate at maximum speed with a circumferential speed of 30 m/s. They are not balanced for standard delivery.

Shrink disk hubs:

Shrink disk hubs maintain balance quality $G = 6.3$ up to speed n_G (equals approx. 30 m/s) without needing to be balanced. Above this speed, we recommend balancing. The hubs are balanced individually. Diagram 1 shows reference values. We recommend you use these values to balance the coupling components.

Smooth running of a machine or system is not only dependent on the balance quality of the coupling, but also on many parameters such as rigidity or distance to the adjacent bearing. Therefore there are no fixed rules in which conditions you have to balance.

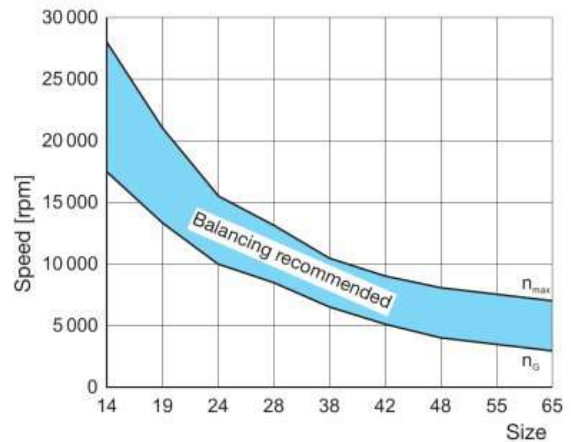

Diagram 1: Balancing the Shrink Disk Hubs

Headquarters

Chr. Mayr GmbH + Co. KG
 Eichenstraße 1, D-87665 Mauerstetten
 Tel.: +49 83 41/8 04-0, Fax: +49 83 41/80 44 21
 www.mayr.com, E-Mail: public.mayr@mayr.com



Service Germany/Austria

Baden-Württemberg

Esslinger Straße 7
 70771 Leinfelden-Echterdingen
 Tel.: 07 11/78 26 26 40
 Fax: 07 11/78 26 26 39

Bavaria

Industriestraße 51
 82194 Gröbenzell
 Tel.: 0 81 42/50 19 808

Chemnitz

Bornaer Straße 205
 09114 Chemnitz
 Tel.: 03 71/4 74 18 96
 Fax: 03 71/4 74 18 95

Franken

Unterer Markt 9
 91217 Hersbruck
 Tel.: 0 91 51/81 48 64
 Fax: 0 91 51/81 62 45

Kamen

Herbert-Wehner-Straße 2
 59174 Kamen
 Tel.: 0 23 07/24 26 79
 Fax: 0 23 07/24 26 74

North

Schiefer Brink 8
 32699 Extertal
 Tel.: 0 57 54/9 20 77
 Fax: 0 57 54/9 20 78

Rhine-Main

Kohlhäuser Str. 3-5
 36043 Fulda
 Tel.: 06 61/96 21 02 15

Austria

Pummerinplatz 1, TIZ I, A27
 4490 St. Florian, Austria
 Tel.: 0 72 24/2 20 81-12
 Fax: 0 72 24/2 20 81 89

Branch office

China

Mayr Zhangjiagang
 Power Transmission Co., Ltd.
 Fuxin Road No.1298, Yangshe Town
 215637 Zhangjiagang
 Tel.: 05 12/58 91-75 67
 Fax: 05 12/58 91-75 66
 info@mayr-ptc.cn

France

Mayr France S.A.S.
 Z.A.L. du Minopole
 Rue Nungesser et Coli
 62160 Bully-Les-Mines
 Tel.: 03.21.72.91.91
 Fax: 03.21.29.71.77
 contact@mayr.fr

Great Britain

Mayr Transmissions Ltd.
 Valley Road, Business Park
 Keighley, BD21 4LZ
 West Yorkshire
 Tel.: 0 15 35/66 39 00
 Fax: 0 15 35/66 32 61
 sales@mayr.co.uk

Italy

Mayr Italia S.r.l.
 Viale Veneto, 3
 35020 Saonara (PD)
 Tel.: 049/879 10 20
 Fax: 049/879 10 22
 info@mayr-italia.it

Japan

Mayr Japan LLC
 Higano Nihonbashi Building 2F
 1-1-9 Nihonbashi Kakigaracho,
 Chuo-ku
 Tokyo
 Tel.: 03/35 27-29 00
 Fax: 03/35 27-26 61
 public.mayr@mayr.co.jp

Singapore

Mayr Transmission (S) PTE Ltd.
 No. 8 Boon Lay Way Unit 03-06,
 TradeHub 21
 Singapore 609964
 Tel.: 00 65/65 60 12 30
 Fax: 00 65/65 60 10 00
 info@mayr.com.sg

Switzerland

Mayr Kupplungen AG
 Tobeläckerstraße 11
 8212 Neuhausen am Rheinfall
 Tel.: 0 52/6 74 08 70
 Fax: 0 52/6 74 08 75
 info@mayr.ch

USA

Mayr Corporation
 10 Industrial Avenue
 Mahwah
 NJ 07430
 Tel.: 2 01/4 45-72 10
 Fax: 2 01/4 45-80 19
 info@mayrcorp.com

Representatives

Australia

Drive Systems Pty Ltd.
 8/32 Melverton Drive
 Hallam, Victoria 3803
 Australien
 Tel.: 0 3/97 96 48 00
 info@drivesystems.com.au

India

National Engineering
 Company (NENCO)
 J-225, M.I.D.C.
 Bhosari Pune 411026
 Tel.: 0 20/27 13 00 29
 Fax: 0 20/27 13 02 29
 nenco@nenco.org

Netherlands

Groneman BV
 Amarilstraat 11
 7554 TV Hengelo OV
 Tel.: 074/2 55 11 40
 Fax: 074/2 55 11 09
 aandrijftechniek@groneman.nl

Poland

Wamex Sp. z o.o.
 ul. Pozaryskiego, 28
 04-703 Warszawa
 Tel.: 0 22/6 15 90 80
 Fax: 0 22/8 15 61 80
 wamex@wamex.com.pl

South Korea

Mayr Korea Co. Ltd.
 15, Yeondeok-ro 9beon-gil
 Seongsan-gu
 51571 Changwon-si
 Gyeongsangnam-do, Korea
 Tel.: 0 55/2 62-40 24
 Fax: 0 55/2 62-40 25
 info@mayrkorea.com

Taiwan

German Tech
 Component Co., Ltd.
 No.10-3, Ln. 358, Sec. 1,
 Hemu Rd., Shengang Dist.,
 429012 Taichung City
 Tel.: +886 (4) 25150566
 Fax: +886 (4) 25152413
 abby@zfgta.com.tw

Czech Republic

BMC - TECH s.r.o.
 Hviezdoslavova 29 b
 62700 Brno
 Tel.: 05/45 22 60 47
 Fax: 05/45 22 60 48
 info@bmc-tech.cz

Turkey

Representative Office Turkey
 Kucukbakkalkoy Mah.
 Brandium Residence R2
 Blok D:254
 34750 Atasehir - Istanbul, Turkey
 Tel.: 02 16/2 32 20 44
 Fax: 02 16/5 04 41 72
 info@mayr.com.tr

More representatives:

Belgium, Brazil, Canada, Colombia, Croatia, Denmark, Finland, Greece, Hongkong, Hungary, Indonesia, Israel, Luxembourg, Malaysia, Mexico, New Zealand, Norway, Philippines, Portugal, Romania, Russia, Slovakia, Slovenia, South Africa, Spain, Sweden, Thailand

You can find the complete contact details for the representative responsible for your area in the Contact section at www.mayr.com

